

Spannzange / collet ER32 DIN6499  
 Spannbereich / clamping range: 2,0 - 20,0

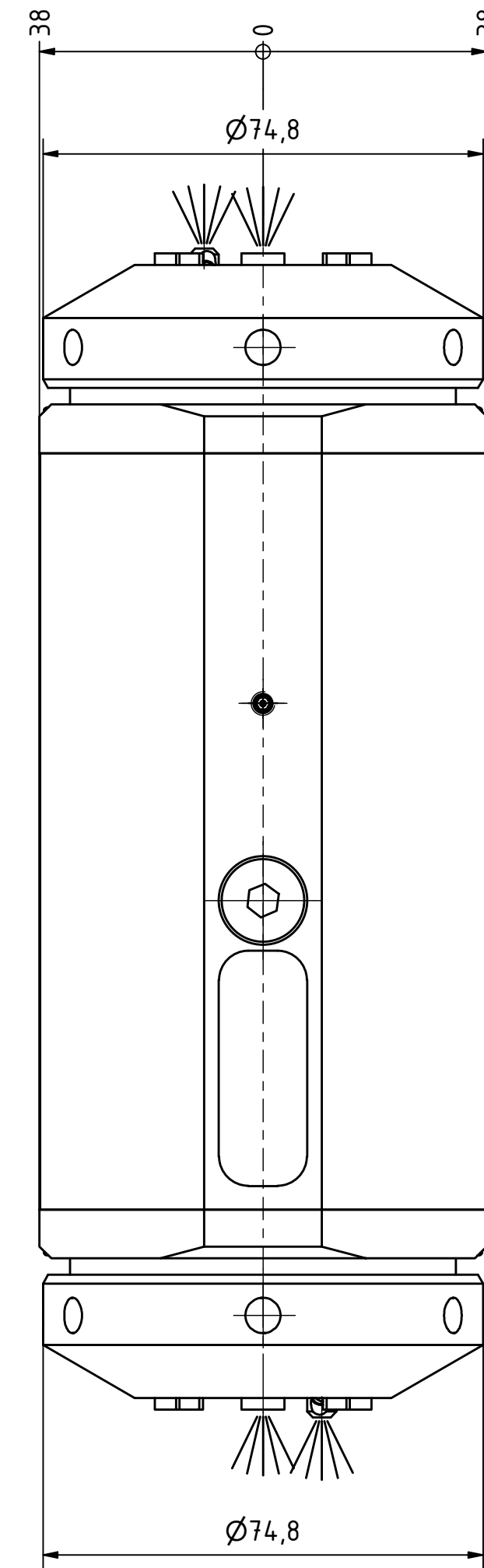

Spannzange / collet ER32 DIN6499  
 Spannbereich / clamping range: 2,0 - 20,0

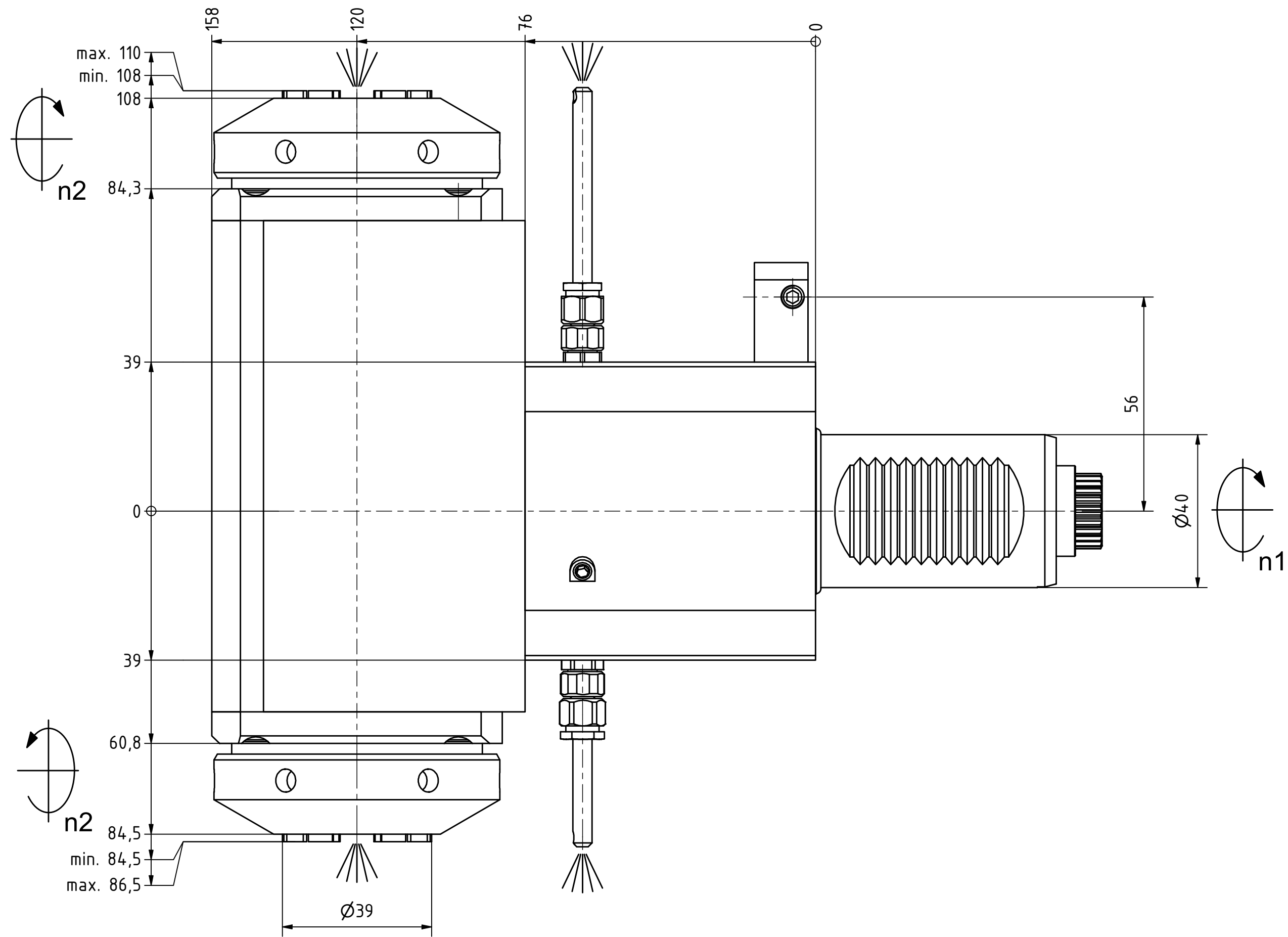
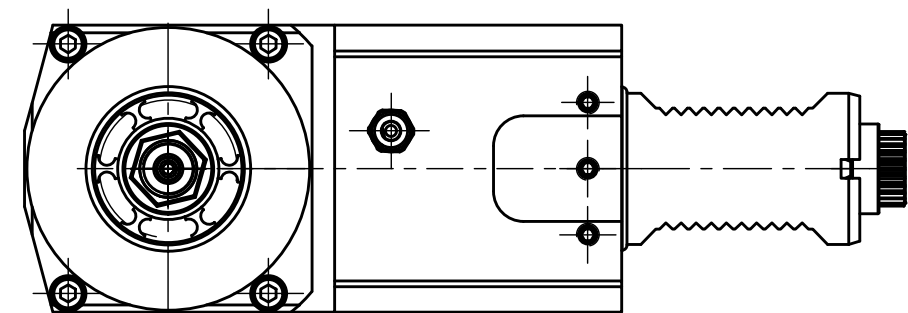

Doppelverzahnung Lizenz Traub  
 double tooth system licence Traub

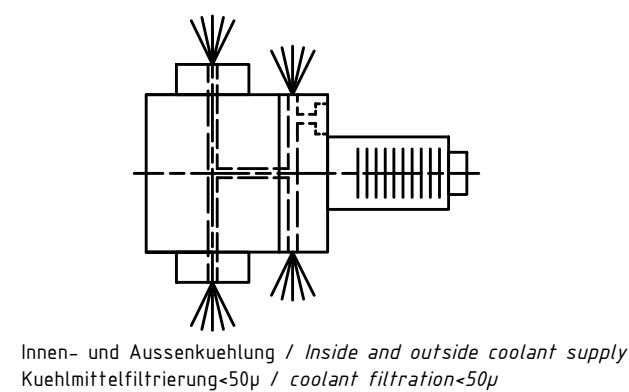
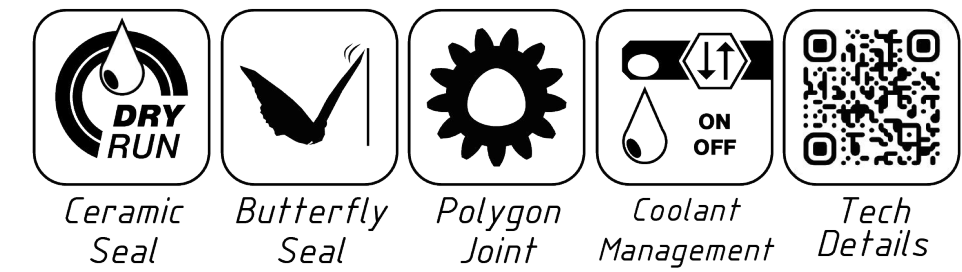
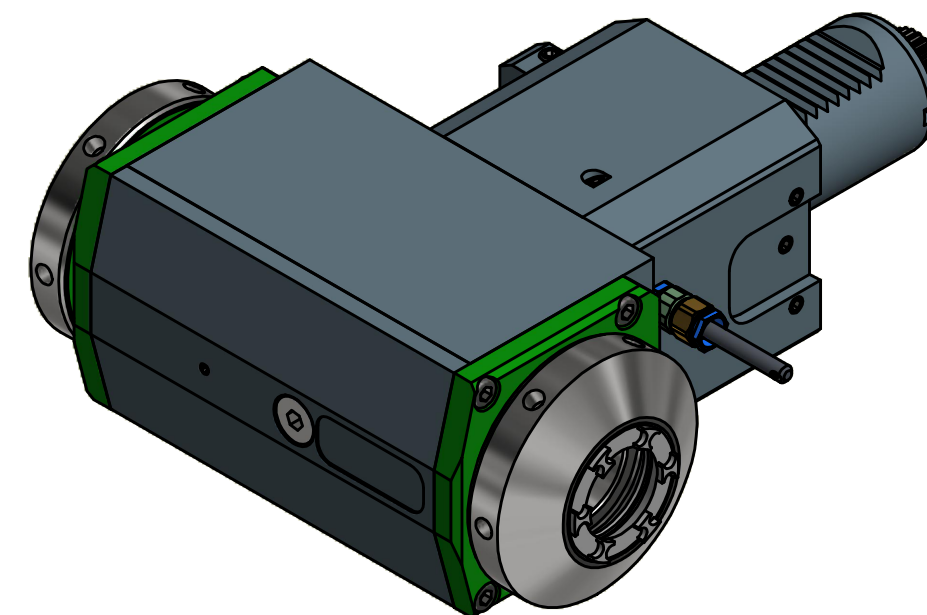

Innen- und Aussenkuehlung / Inside and outside coolant supply  
 Kuehlmittelfiltrierung<50µ / coolant filtration<50µ

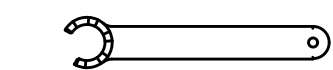

Spannzangenschlüssel für innenliegende Mutter  
 Clamping wrench for internal collet  
 232AX

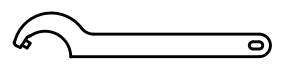

Hakenschlüssel mit Zapfen  
 Hook wrench with fixed pin  
 DIN1810 B 68x75

Copyright **EWS Tool Technologies**  
 Weitergabe und Vervielfaeltigung dieser Unterlage, Verwertung und Mitteilung ihres Inhalts nicht gestattet, soweit nicht ausdrecklich zugestanden. Zuwiderhandlungen verpflichten zu Schadenersatz.

Bemerkung - Note Für Trockenlauf geeignet! Use without coolant fluid allowed!	Technische Daten - technical data Weight = 10.261 [kg] Torque max. (M1/M2) = 63 / 63   63 [Nm] Speed max. (n1/n2) = 6000 / 6000   6000 [1/min] Gear ratio (i)=n1:n2 = 1:1   1:1 Pressure (pmax) = 70 [bar]
---	---

Benennung - Title  
**Radial Bohr und Fräskopf**  
 Radial drilling and milling head

<b>EWS</b> Tool Technologies EWS Weigle GmbH & Co. KG Maybachstr. 1 D-73066 Uhlingen www.ews-tool.de	Technische Aenderungen vorbehalten! Subject to technical modifications! IDENT: DEWS137776	Nr. - No. 60.4032LDCTXRLIKDIM	REV: -/A MNR. 224695	
---	---	----------------------------------	----------------------------	--