

Spannzange / collet ER32 DIN6499  
Spannbereich / clamping range: 2,0 - 20,0

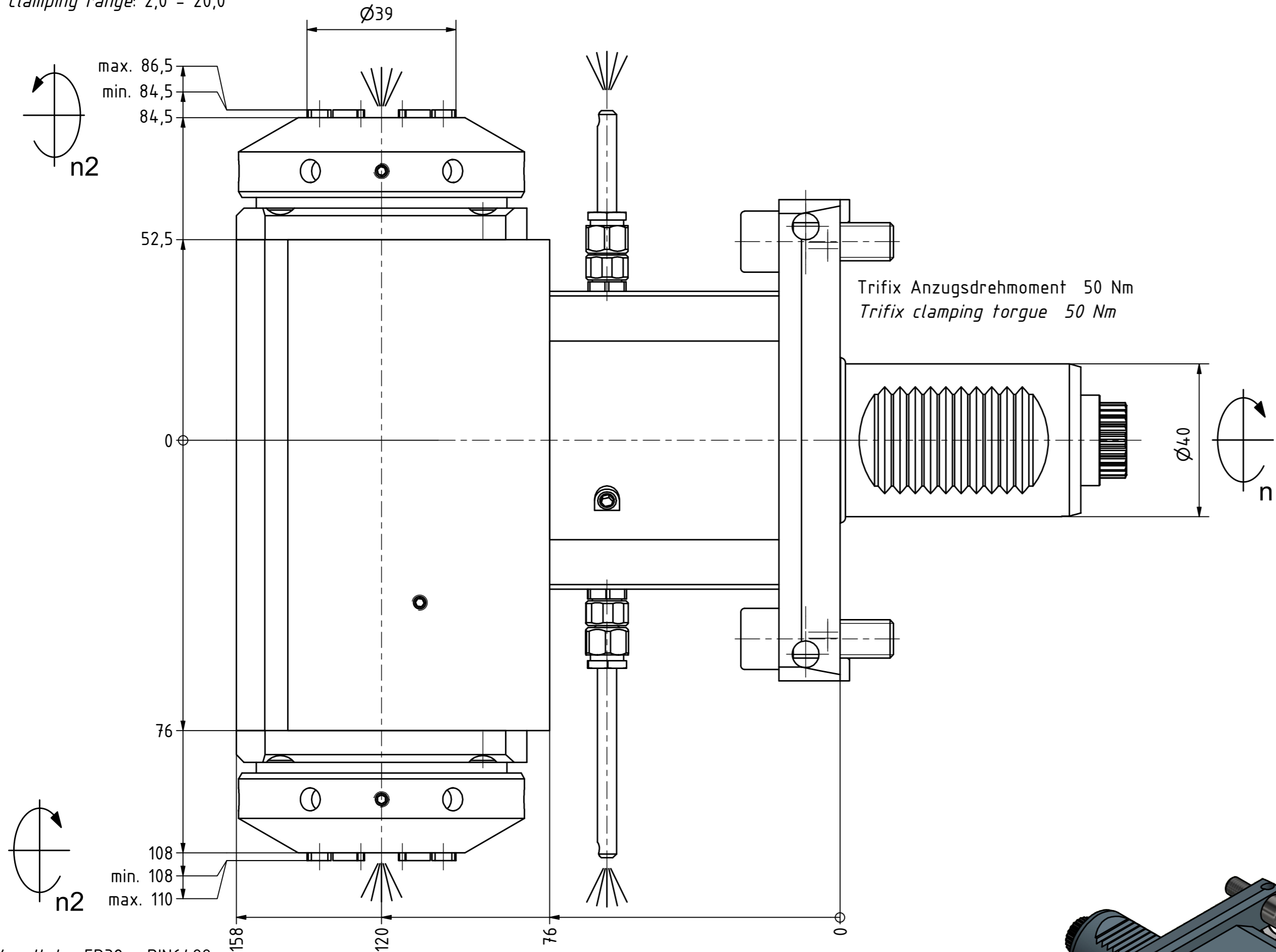

Spannzange / collet ER32 DIN6499  
Spannbereich / clamping range: 2,0 - 20,0

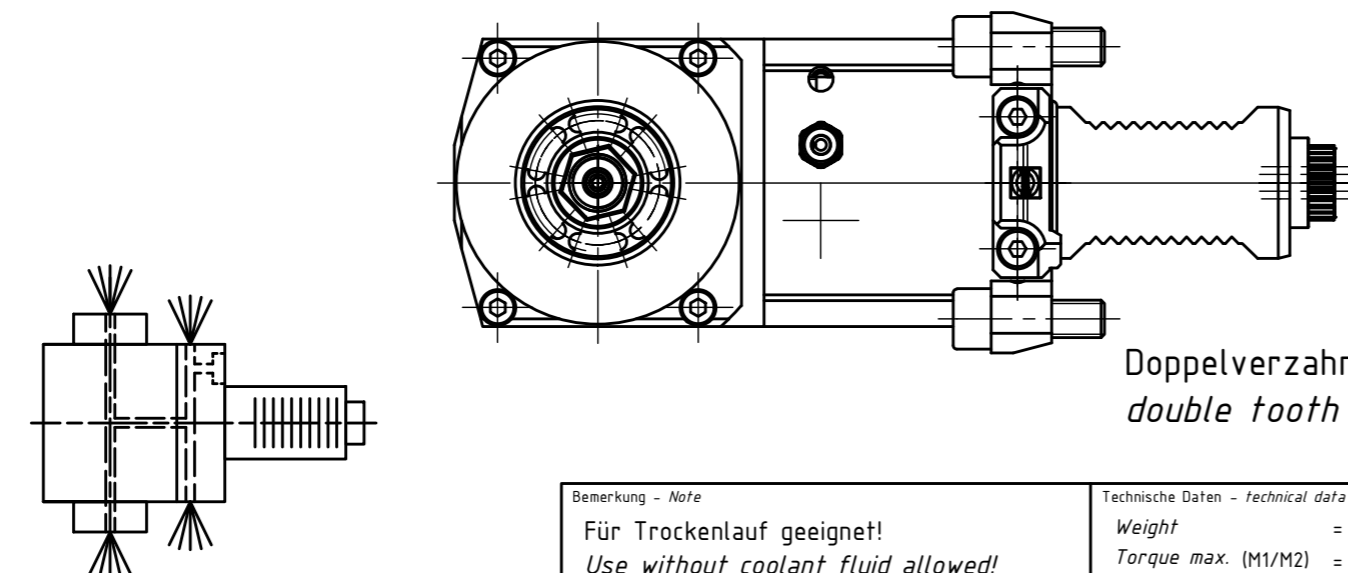
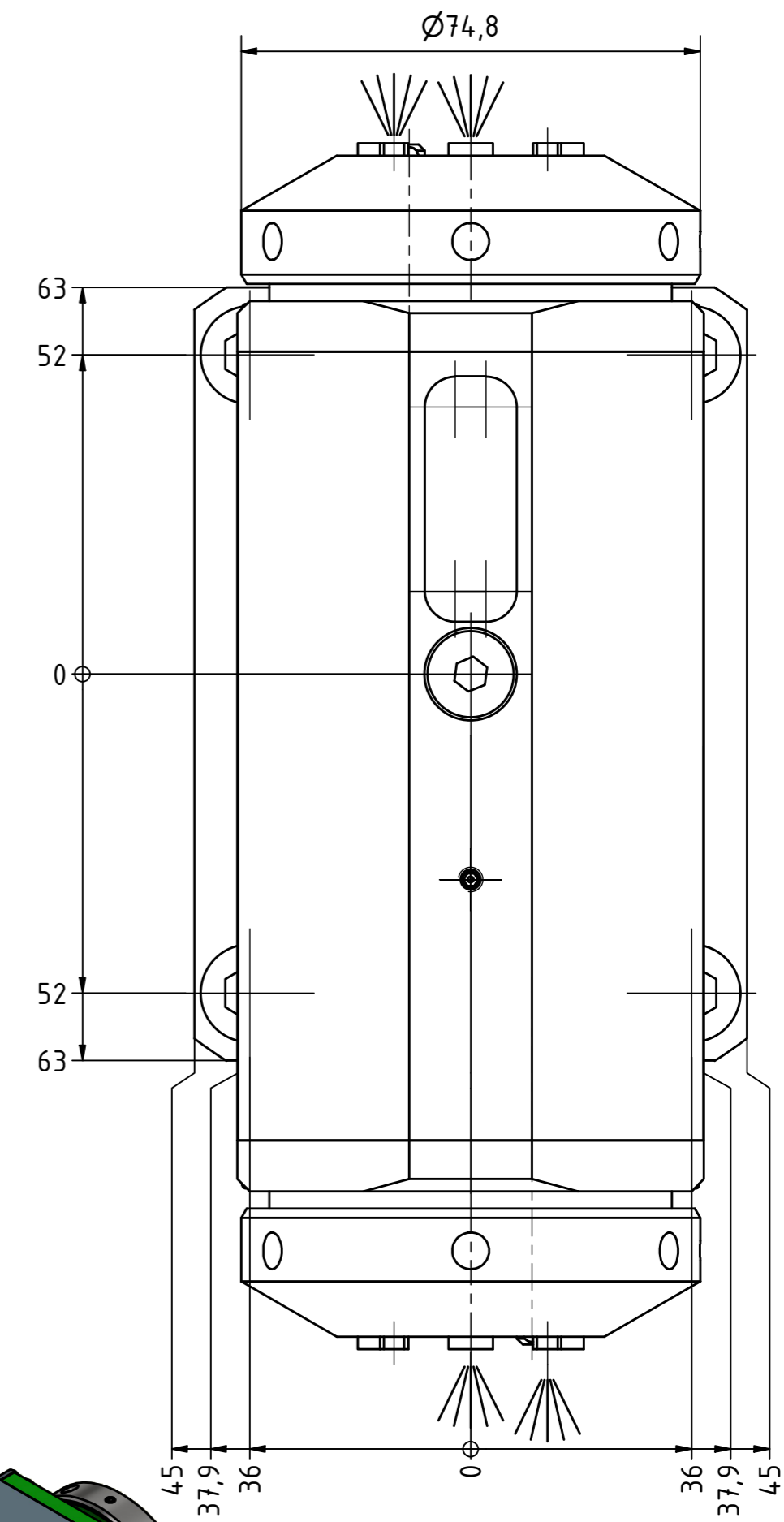

Innen- und Aussenkuehlung / Inside and outside coolant supply  
Kuehlmittelfiltrierung=50 $\mu$  / coolant filtration=50 $\mu$

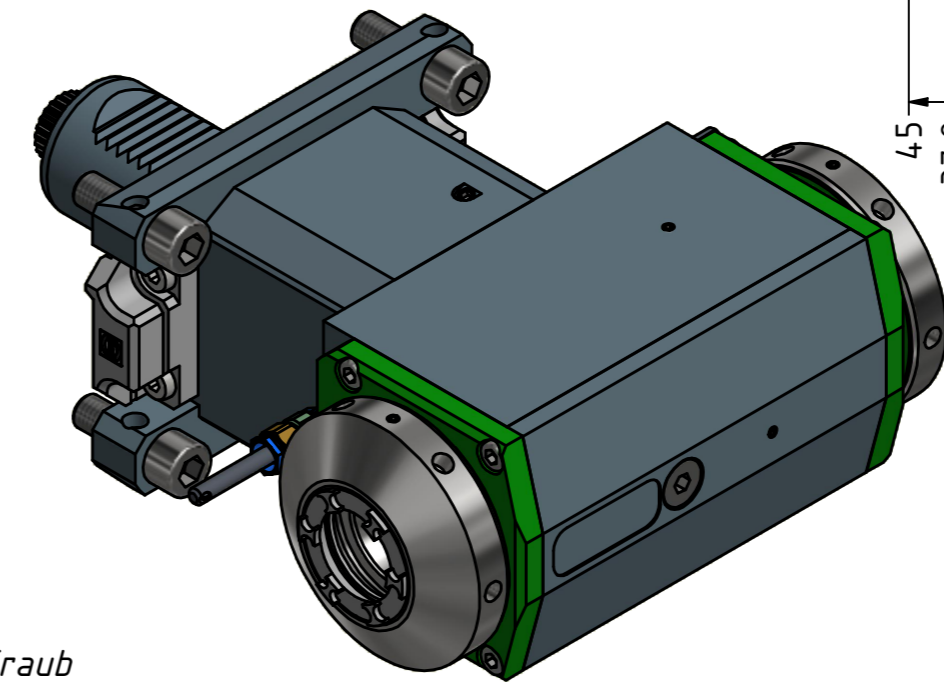

Spannzangenschlüssel für innenliegende Mutter  
*Clamping wrench for internal collet*  
**232AX**

Hakenschlüssel mit Nase  
*Hook wrench with nose end*  
**DIN1810 A 68x75**

Copyright **EWS Tool Technologies**  
Weitergabe und Vervielfaeltigung dieser Unterlage,  
Verwertung und Mitteilung ihres Inhalts nicht  
gestattet, soweit nicht ausdrecklich zugestanden.  
Zuwoerhandlungen verpflichten zu Schadenersatz.

|   |   |
|---|---|
| Bemerkung - Note<br>Für Trockenlauf geeignet!<br>Use without coolant fluid allowed! | Technische Daten - technical data               |
|   | Weight = 10.842 [kg]                            |
|   | Torque max. (M1/M2) = 50 / 50   50 [Nm]         |
|   | Speed max. (n1/n2) = 6000 / 6000   6000 [1/min] |
|   | Gear ratio (i)=n1:n2 = 1:1   1:1                |
| Pressure (pmax) = 70 [bar]  |   |

Benennung - Title  
**Radial Bohr und Fräskopf**  
**Radial drilling and milling head**

|   |  |  |                       |
|---|--|--|-----------------------|
| <b>EWS</b><br>Tool Technologies               | EWS Weigle GmbH & Co. KG<br>Maybachstr. 1<br>D-73066 Uhlingen<br>www.ews-tool.de | Technische Aenderungen vorbehalten!<br>Subject to technical modifications! | REV: -/A              |
|   | IDENT: DEWS138082  | MNR.   |                       |
| Nr. - No.<br><b>60.4032LDCTXRLIKDTFLIM-PL</b> |  |  | MNR.<br><b>224722</b> |

