

Spannzange / collet ER32 DIN6499
Spannbereich / clamping range: 2,0 - 20,0

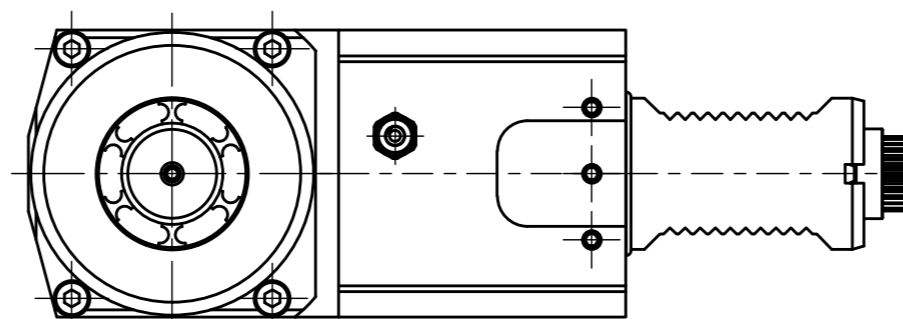

Doppelverzahnung Lizenz Traub
double tooth system licence Traub

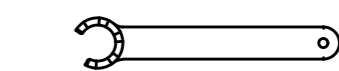
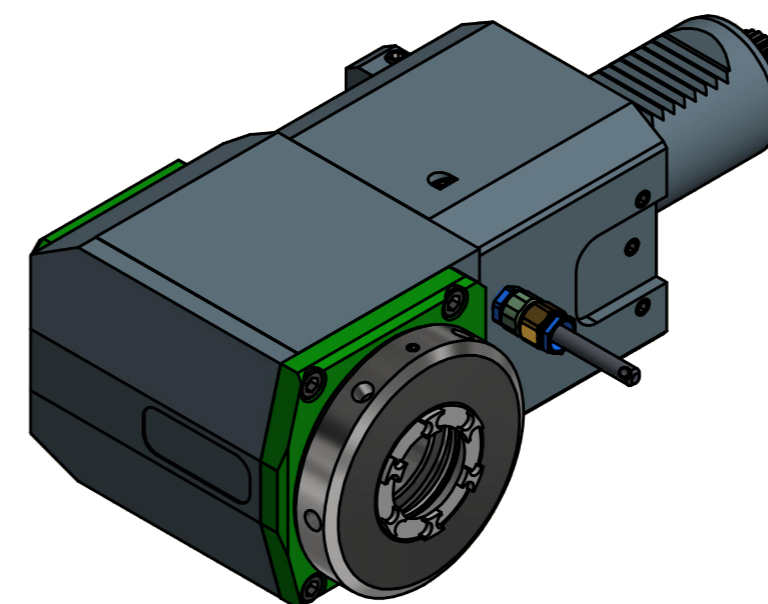

Spannzangenschlüssel für innenliegende Mutter
Clamping wrench for internal collet
232AX

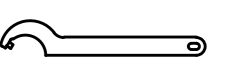

Hakenschlüssel mit Zapfen
Hook wrench with fixed pin
DIN1810 B 68x75

Copyright **EWS Tool Technologies**
Weitergabe und Vervielfältigung dieser Unterlage, Verwertung und Mitteilung ihres Inhalts nicht gestattet, soweit nicht ausdrücklich zugestanden. Zuwiderhandlungen verpflichten zu Schadenersatz.

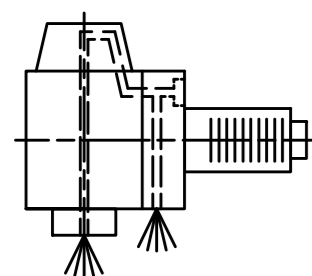

Innen- und Aussenkühlung / Inside and outside coolant supply
Kuehlmittelfiltrierung-50µ / coolant filtration-50µ

Bemerkung - Note
Für Trockenlauf geeignet!
Use without coolant fluid allowed!

Technische Daten - technical data	
Weight	= 7.569 [kg]
Torque max. (M1/M2)	= 63 / 63 [Nm]
Speed max. (n1/n2)	= 6000 / 6000 [1/min]
Gear ratio (i)=n1:n2	= 1:1
Pressure (pmax)	= 70 [bar]

Benennung - Title
Radial Bohr und Fräskopf
Radial drilling and milling head

EWS Tool Technologies
EWS Weigle GmbH & Co. KG
Maybachstr. 1
D-73066 Uhlingen
www.ews-tools.de

Technische Änderungen vorbehalten!
Subject to technical modifications!
IDENT: DEWS137764

REV: -/A
MNR.

Nr. - No.
60.4032LCTXRLIKDIM#01

224693

