

Spannzange / collet ER32 DIN6499
Spannbereich / clamping range: 2,0 - 20,0

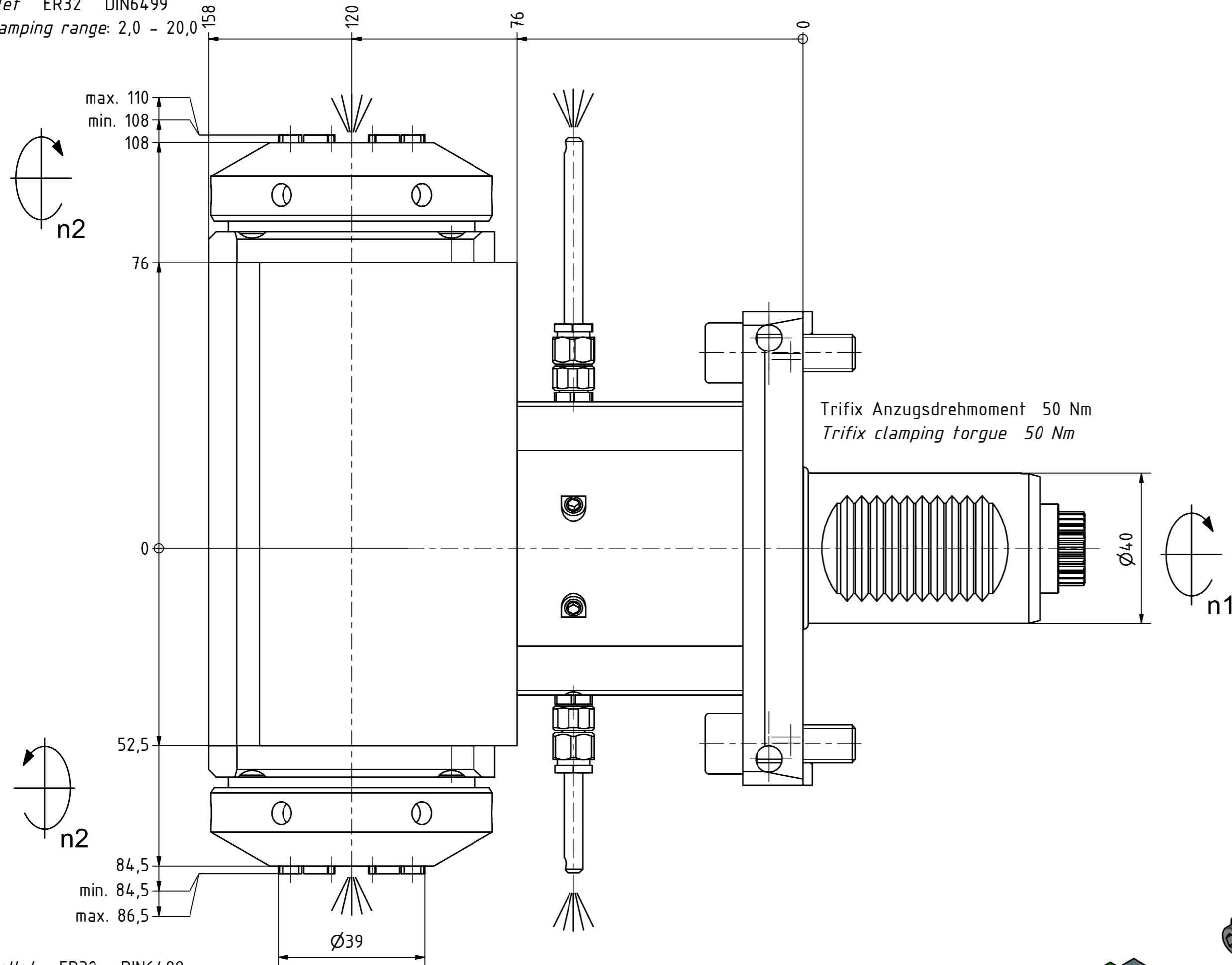

Spannzange / collet ER32 DIN6499
Spannbereich / clamping range: 2,0 - 20,0

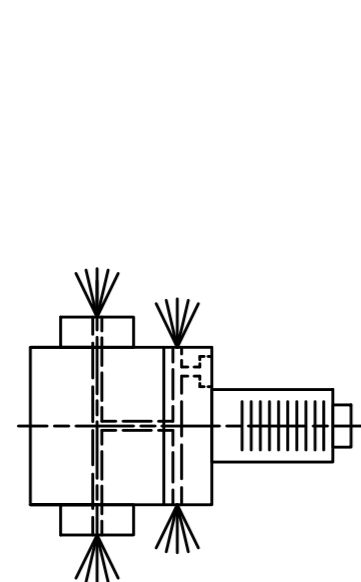
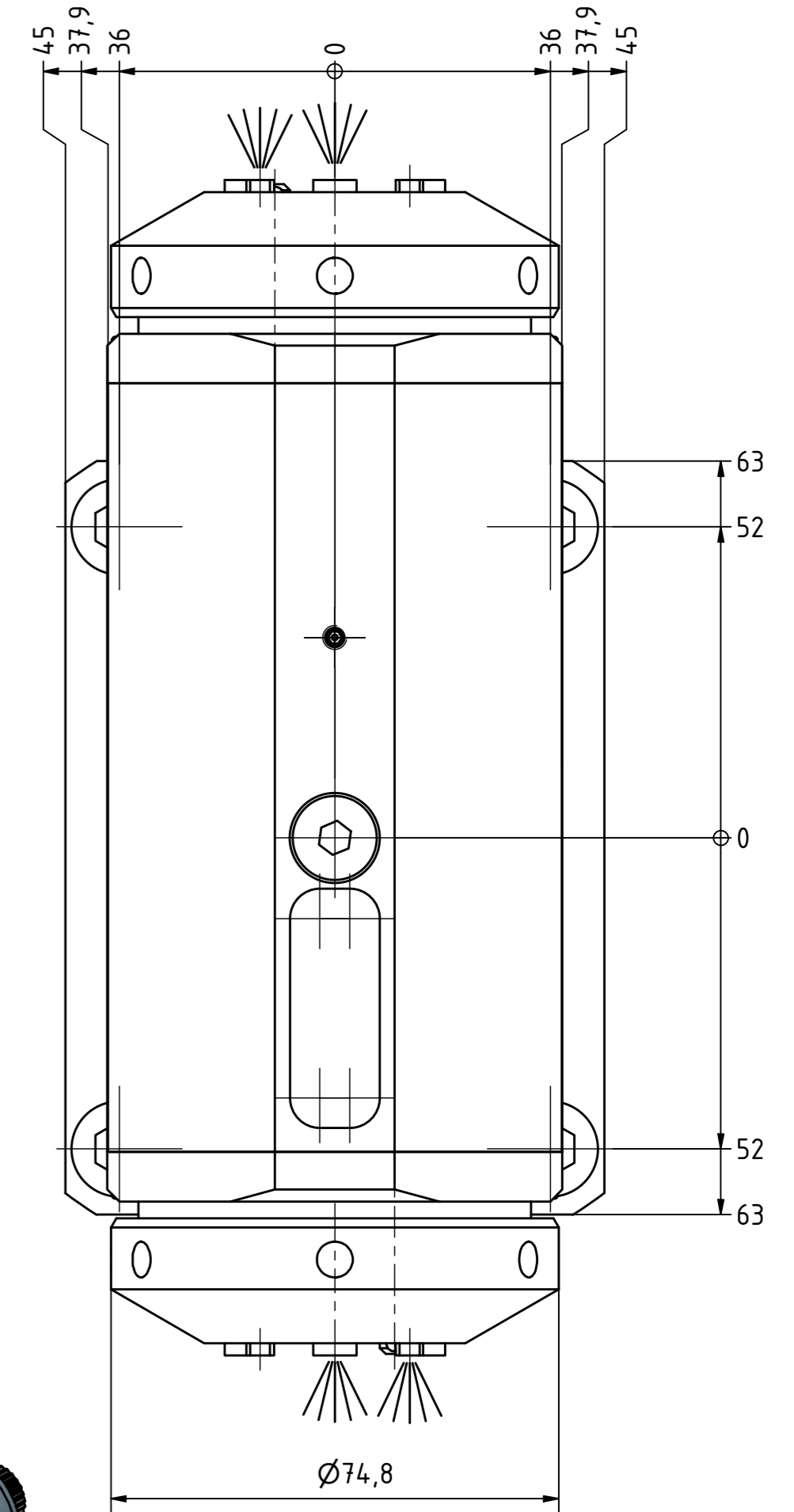

Innen- und Aussenkuehlung / Inside and outside coolant supply
Kuehlmittelfiltrierung=50µ / coolant filtration=50µ

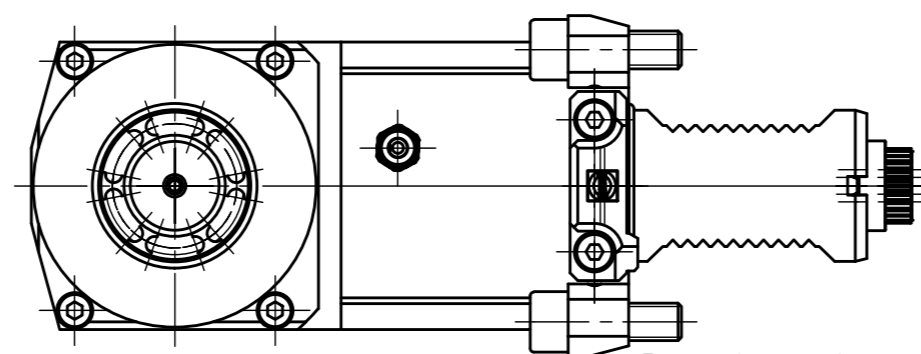

Doppelverzahnung Lizenz Traub
double tooth system licence Traub

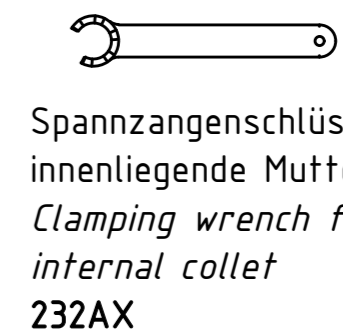
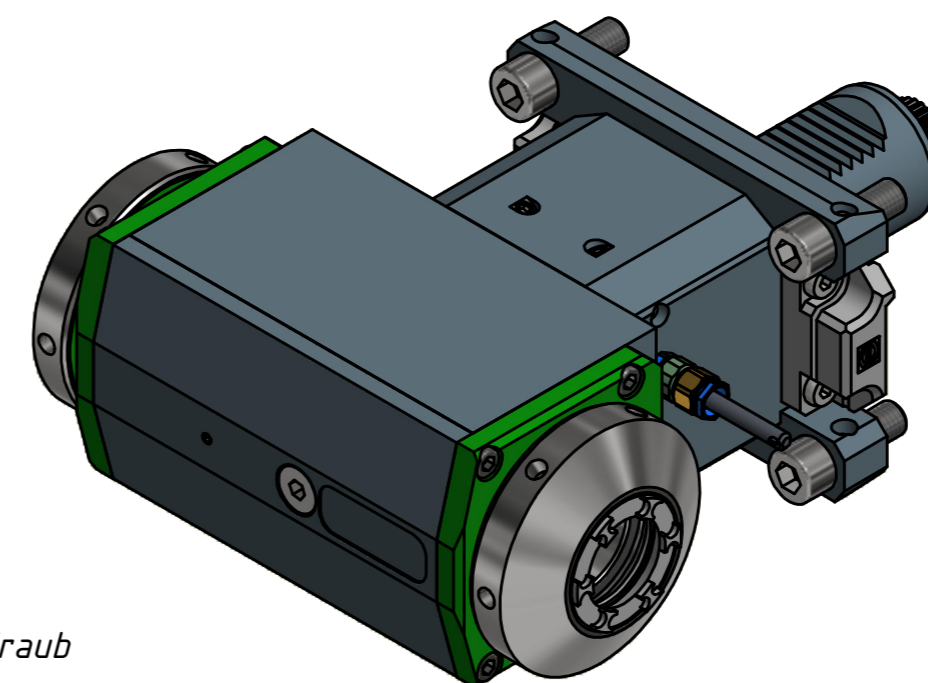

Copyright EWS Tool Technologies
Weitergabe und Vervielfaeltigung dieser Unterlage, Verwertung und Mitteilung ihres Inhalts nicht gestattet, soweit nicht ausdrecklich zugestanden. Zuwiderhandlungen verpflichten zu Schadenersatz.

Bemerkung - Note
Für Trockenlauf geeignet!
Use without coolant fluid allowed!

Technische Daten - technical data
Weight = 10.842 [kg]
Torque max. (M1/M2) = 50 / 50 | 50 [Nm]
Speed max. (n1/n2) = 6000 / 6000 | 6000 [1/min]
Gear ratio (i)=n1:n2 = 1:1 | 1:1
Pressure (pmax) = 70 [bar]

Benennung - Title
Radial Bohr und Fräskopf
Radial drilling and milling head

| | | | |
|---------------------------------------|--|--|--|
| | <small>EWS Weigle GmbH & Co. KG Maybachstr. 1 D-73066 Uhlingen www.ews-tool.de</small> | Technische Aenderungen vorbehalten! Subject to technical modifications! | |
| | | IDENT: DEWS138072 | |
| Nr. - No. 60.4032LDCTXRLIKDTRIM-PL | | MNR. 224721 | |