

Spannzange / collet ER32 DIN6499
Spannbereich / clamping range: 2,0 - 20,0

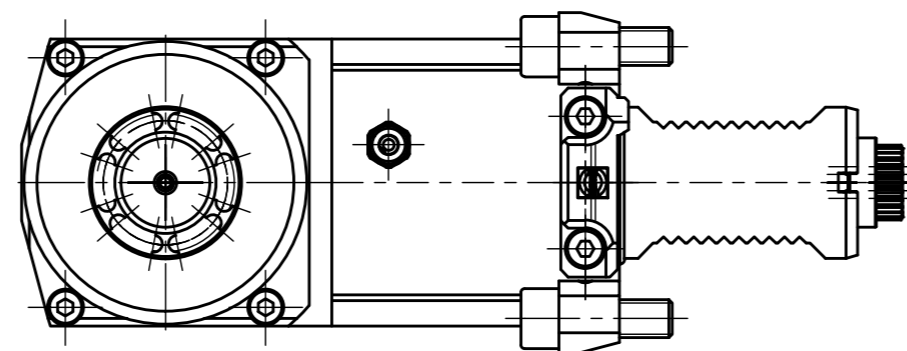

Doppelverzahnung Lizenz Traub
double tooth system licence Traub

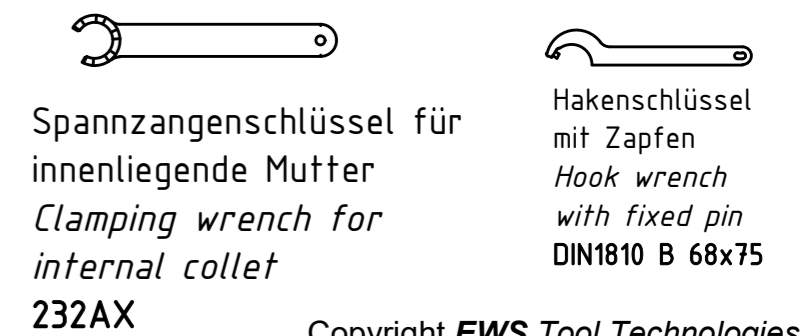
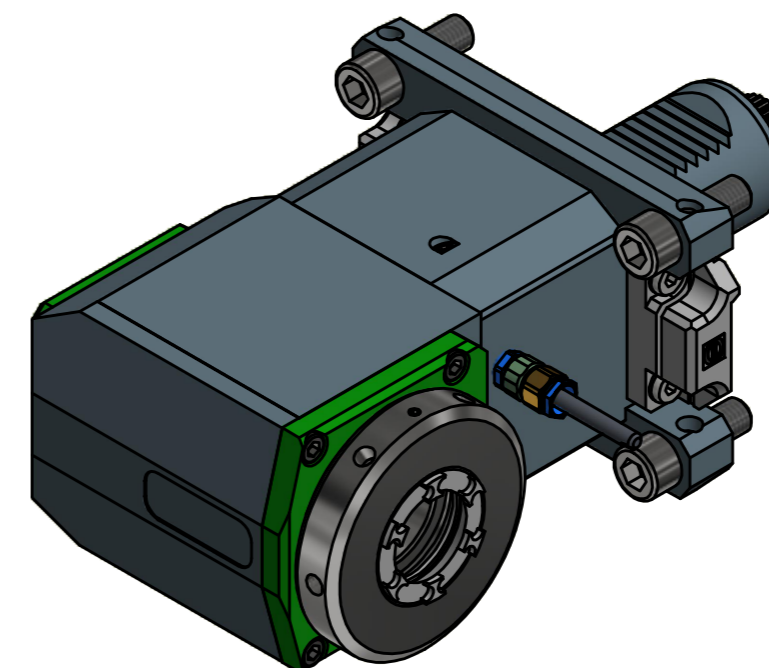

Spannzangenschlüssel für innenliegende Mutter
Clamping wrench for internal collet
232AX

Hakenschlüssel mit Zapfen
Hook wrench with fixed pin
DIN1810 B 68x75

Copyright EWS Tool Technologies
Weitergabe und Vervielfältigung dieser Unterlage, Verwertung und Mitteilung ihres Inhalts nicht gestattet, soweit nicht ausdrücklich zugestanden. Zuwiderhandlungen verpflichten zu Schadenersatz.

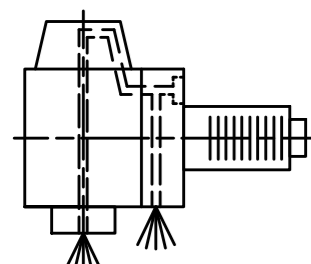

Innen- und Aussenkühlung / Inside and outside coolant supply
Kühlmittelfiltrierung=50µ / coolant filtration=50µ

Bemerkung - Note Für Trockenlauf geeignet! Use without coolant fluid allowed!	Technische Daten - technical data
	Weight = 8,155 [kg]
	Torque max. (M1/M2) = 63 / 63 [Nm]
	Speed max. (n1/n2) = 6000 / 6000 [1/min]
	Gear ratio (i)=n1:n2 = 1:1
Pressure (pmax) = 70 [bar]	

Benennung - Title
Radial Bohr und Fräskopf
Radial drilling and milling head

EWS Tool Technologies <small>EWS Weigle GmbH & Co. KG Maybachstr. 1 D-73066 Uhingen www.ews-tools.de</small>	Technische Änderungen vorbehalten! Subject to technical modifications! IDENT: DEWS138037	MNR. REV: -/A
	Nr. - No. 60.4032LCTXRLIKDTFRIM-PL	224718

