

Spannzange / collet ER25 DIN6499
Spannbereich / clamping range: 1,0 - 16,0

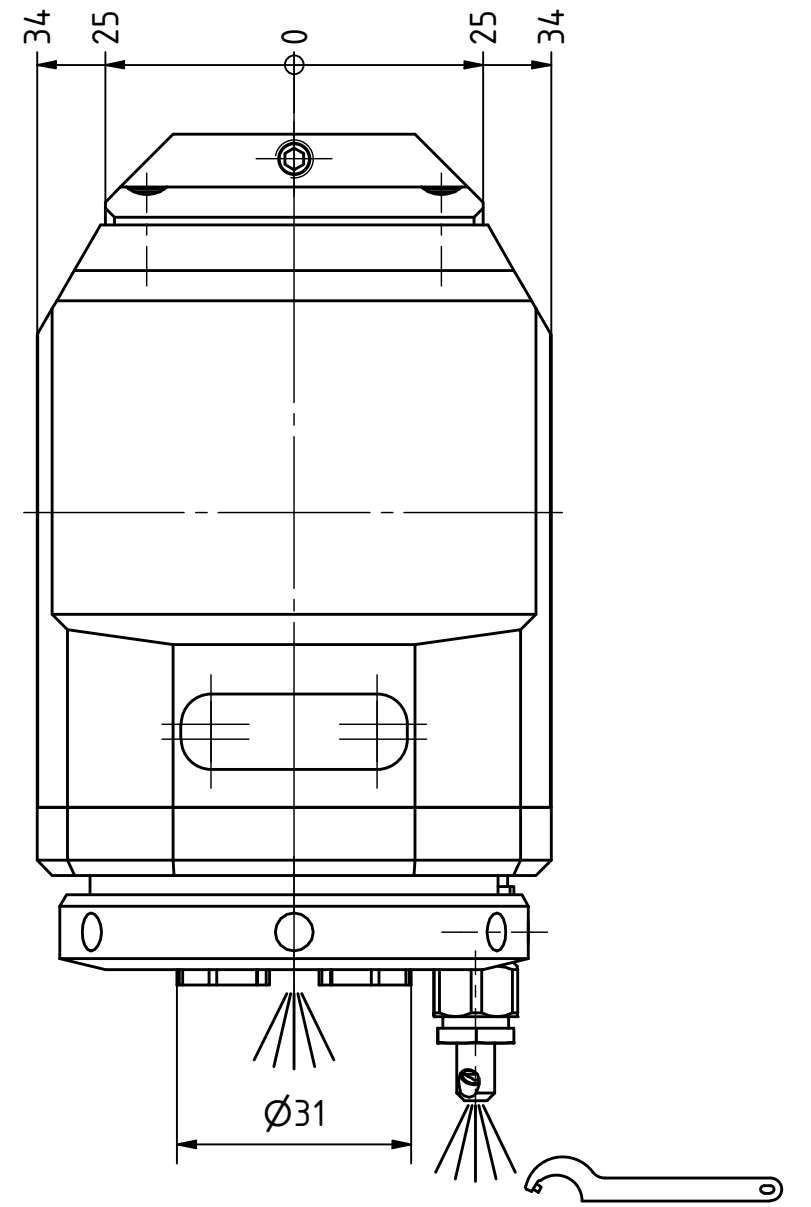

Hakenschlüssel mit Zapfen
Hook wrench with fixed pin
DIN1810 B 58x62

Spannzangenschlüssel für innenliegende Mutter
Clamping wrench for internal collet
225AX

Doppelverzahnung Lizenz Traub
double tooth system licence Traub

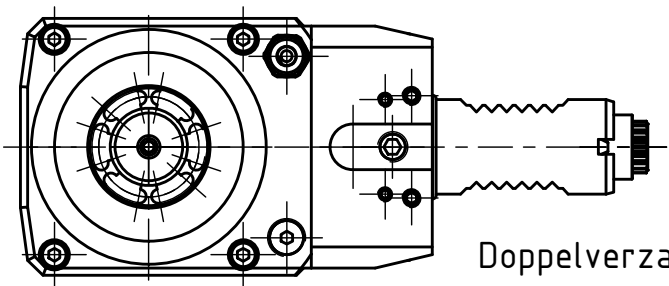
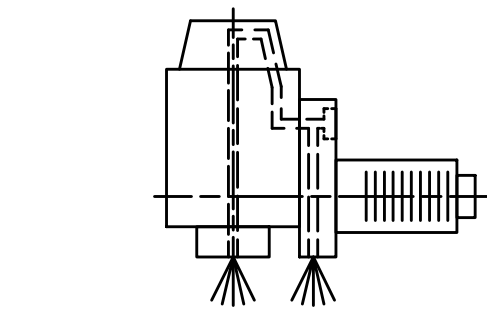
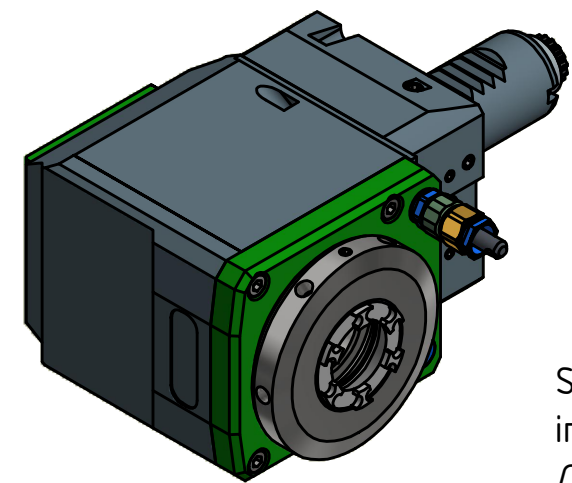

Innen- und Aussenkuehlung / Inside and outside coolant supply
Kuehlmittelfiltrierung <math>< 50\mu</math> / coolant filtration <math>< 50\mu</math>

Bemerkung - Note
Für Trockenlauf geeignet!
Use without coolant fluid allowed!

Technische Daten - technical data	
Weight	= 3.922 [kg]
Torque max. (M1/M2)	= 25 / 25 [Nm]
Speed max. (n1/n2)	= 8000 / 8000 [1/min]
Gear ratio (i)=n1:n2	= 1:1
Pressure (pmax)	= 70 [bar]

Benennung - Title
Radial Bohr und Fräskopf
Radial drilling and milling head

 EWS Weigle GmbH & Co. KG Maybachstr. 1 D-73066 UHINGEN www.ews-tools.de	Technische Aenderungen vorbehalten! Subject to technical modifications! IDENT: DEWS133892	 REV: -/A	
	Nr. - No. 60.2525L5480RLIKDIM	MNR. 224629	