

Spannzange / collet ER32 DIN6499  
Spannbereich / clamping range: 2,0 - 20,0

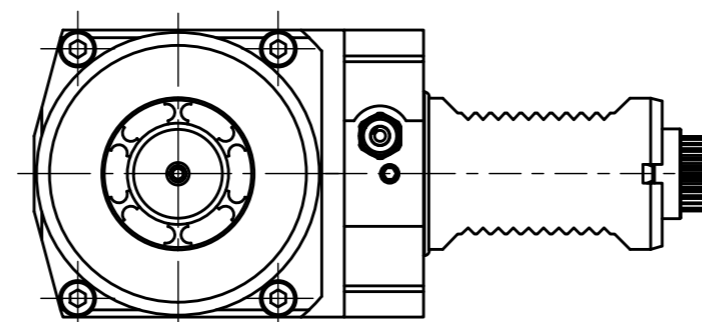

Doppelverzahnung Lizenz Traub  
double tooth system licence Traub

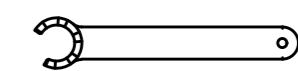
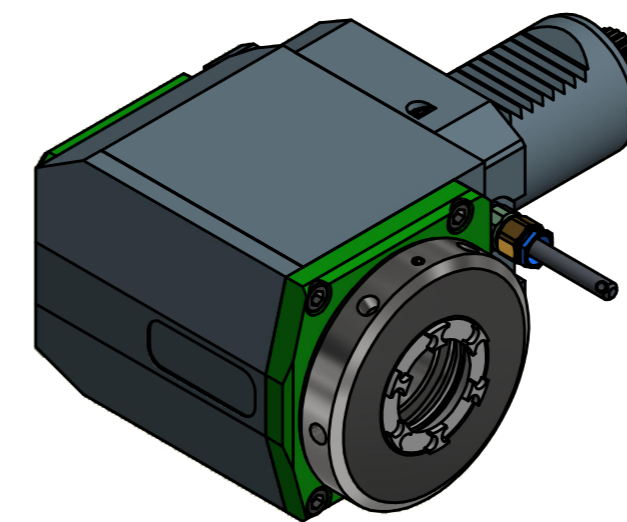

Spannzangenschlüssel für  
innenliegende Mutter  
Clamping wrench for  
internal collet  
232AX

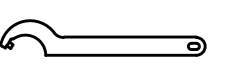

Hakenschlüssel  
mit Zapfen  
Hook wrench  
with fixed pin  
DIN1810 B 68x75

Copyright EWS Tool Technologies  
Weitergabe und Vervielfältigung dieser Unterlage,  
Verwertung und Mitteilung ihres Inhalts nicht  
gestattet, soweit nicht ausdrücklich zugestanden.  
Zu widerhandlungen verpflichten zu Schadenersatz.

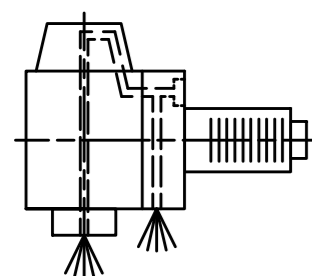

Innen- und Aussenkuehlung / Inside and outside coolant supply  
Kuehlmittefiltrierung-50µ / coolant filtration-50µ

<p>Bemerkung - Note Für Trockenlauf geeignet! Use without coolant fluid allowed!</p>	<p>Technische Daten - technical data Weight = 5,344 [kg] Torque max. (M1/M2) = 63 / 63 [Nm] Speed max. (n1/n2) = 6000 / 6000 [1/min] Gear ratio (i)=n1:n2 = 1:1 Pressure (pmax) = 70 [bar]</p>	<p>Benennung - Title <b>Radial Bohr und Fräskopf</b> <b>Radial drilling and milling head</b></p>	<p><b>EWS</b> Tool Technologies EWS Weigle GmbH &amp; Co. KG Maybachstr. 1 D-73066 Ulm/ingen www.ews-tool.de</p>	<p>Technische Änderungen vorbehalten! Subject to technical modifications! IDENT: DEWS137588 REV: -/A</p>	<p>Nr. - No. <b>60.4032KCTXRLIKDIM</b> MNR. <b>224677</b></p>
--	--	--	--	--	---

