

Doppelverzahnung Lizenz Traub
double tooth system licence Traub

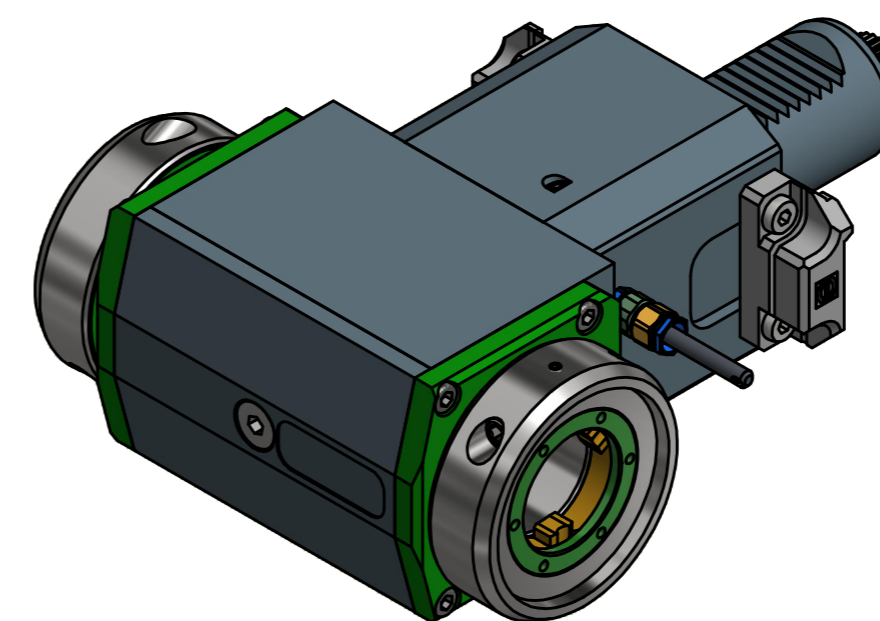

Copyright **EWS Tool Technologies**
Weitergabe und Vervielfältigung dieser Unterlage,
Verwertung und Mitteilung ihres Inhalts nicht
gestattet, soweit nicht ausdrücklich zugestanden.
Zuwiderhandlungen verpflichten zu Schadenersatz.

Benennung - Title	Technische Daten - technical data
	Weight = 9,194 [kg]
	Torque max. (M1/M2) = 63 / 63 63 [Nm]
	Speed max. (n1/n2) = 6000 / 6000 6000 [1/min]
	Gear ratio (i)=n1:n2 = 1:1 1:1

Benennung - Title
Radial Bohr und Fräskopf
Radial drilling and milling head

EWS Tool Technologies	EWS Weigle GmbH & Co. KG Maybachstr. 1 D-73066 Ulm/Ingen www.ews-tools.de	Technische Änderungen vorbehalten! Subject to technical modifications!	IDENT: DEWS137945	REV: -/A
Nr. - No.				
60.40VX4LDCTXRLTF				
			MNR.	
			224 713	

