

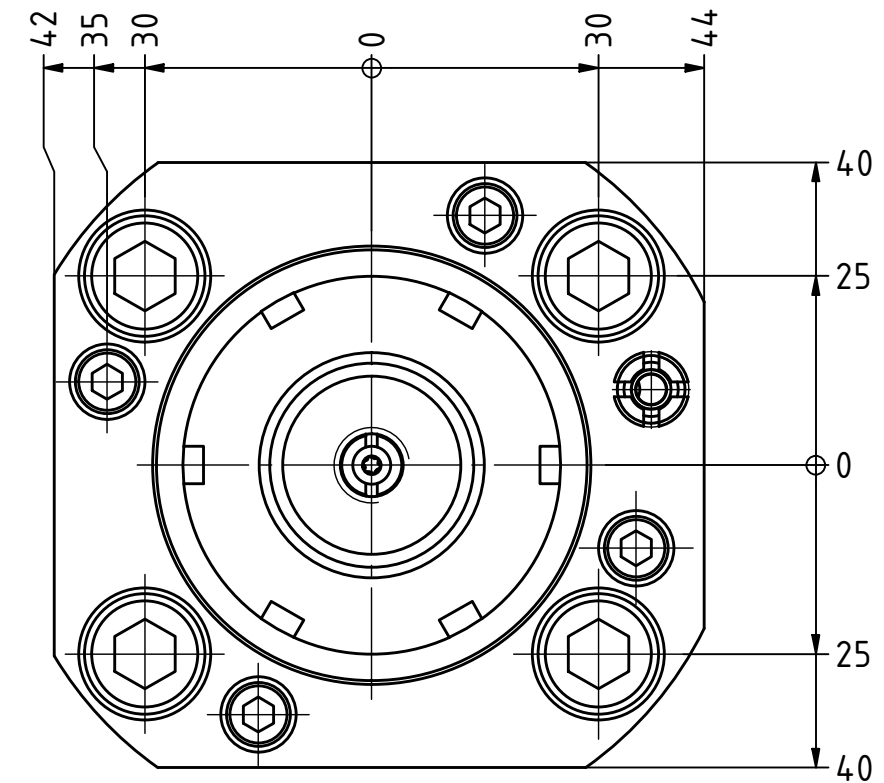

Ceramic Seal

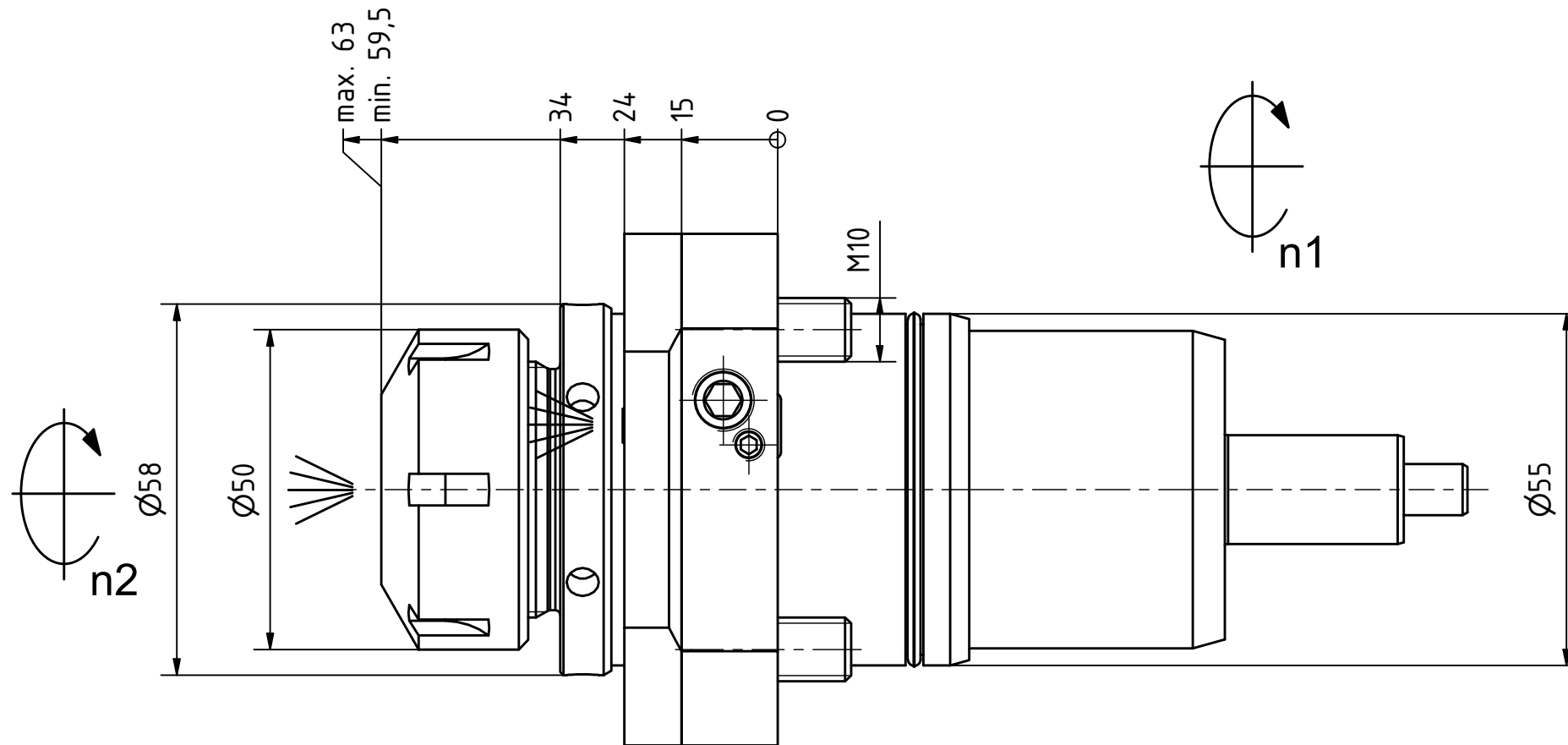

Tech Details



Spannzange / collet ER32 DIN6499
 Spannbereich / clamping range: 2,0 - 20,0

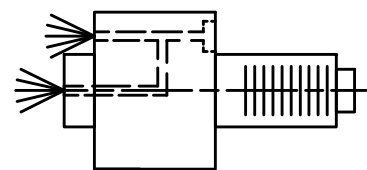

Innen- und Aussenkuehlung / Inside and outside coolant supply
 Kuehlmittelfiltrierung <math>< 50\mu</math> / coolant filtration <math>< 50\mu</math>

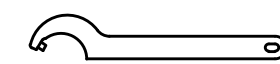
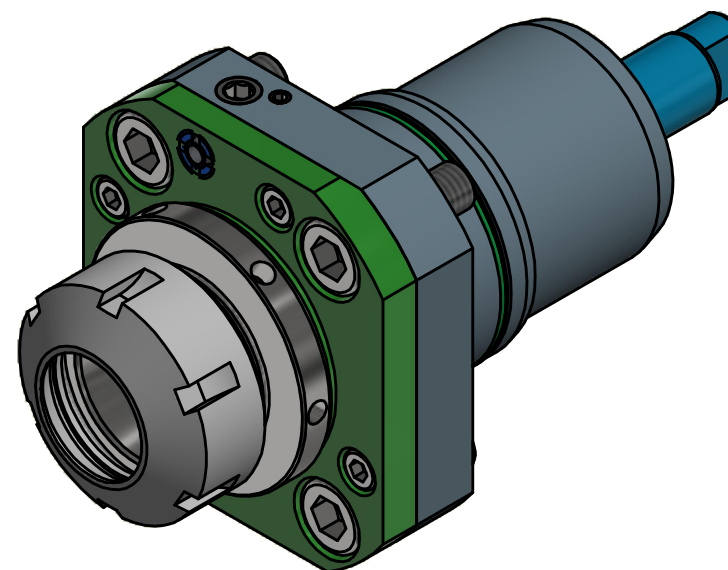

Hakenschlüssel
 mit Zapfen
 Hook wrench
 with fixed pin
 DIN1810 B 58x62

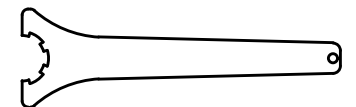

Spannzangenschlüssel
 Clamping wrench
 232

Copyright **EWS Tool Technologies**
 Weitergabe und Vervielfaeltigung dieser Unterlage,
 Verwertung und Mitteilung ihres Inhalts nicht
 gestattet, soweit nicht ausdrucklich zugestanden.
 Zuwiderhandlungen verpflichten zu Schadenersatz.

Bemerkung - Note
 Für Trockenlauf geeignet!
 Use without coolant fluid allowed!

Technische Daten - technical data
 Weight = 2.544 [kg]
 Torque max. (M1/M2) = 25 / 25 [Nm]
 Speed max. (n1/n2) = 6000 / 6000 [1/min]
 Gear ratio (i)=n1:n2 = 1:1
 Pressure (pmax) = 70 [bar]

Benennung - Title
Axial Bohr und Fräskopf
Axial drilling and milling head



Nr. - No.
40.5532TW10IKC

Technische Aenderungen vorbehalten!
 Subject to technical modifications!
 IDENT: DEWS139549

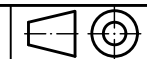

REV: -/A

MNR.
224573

