

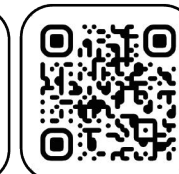

Ceramic Seal

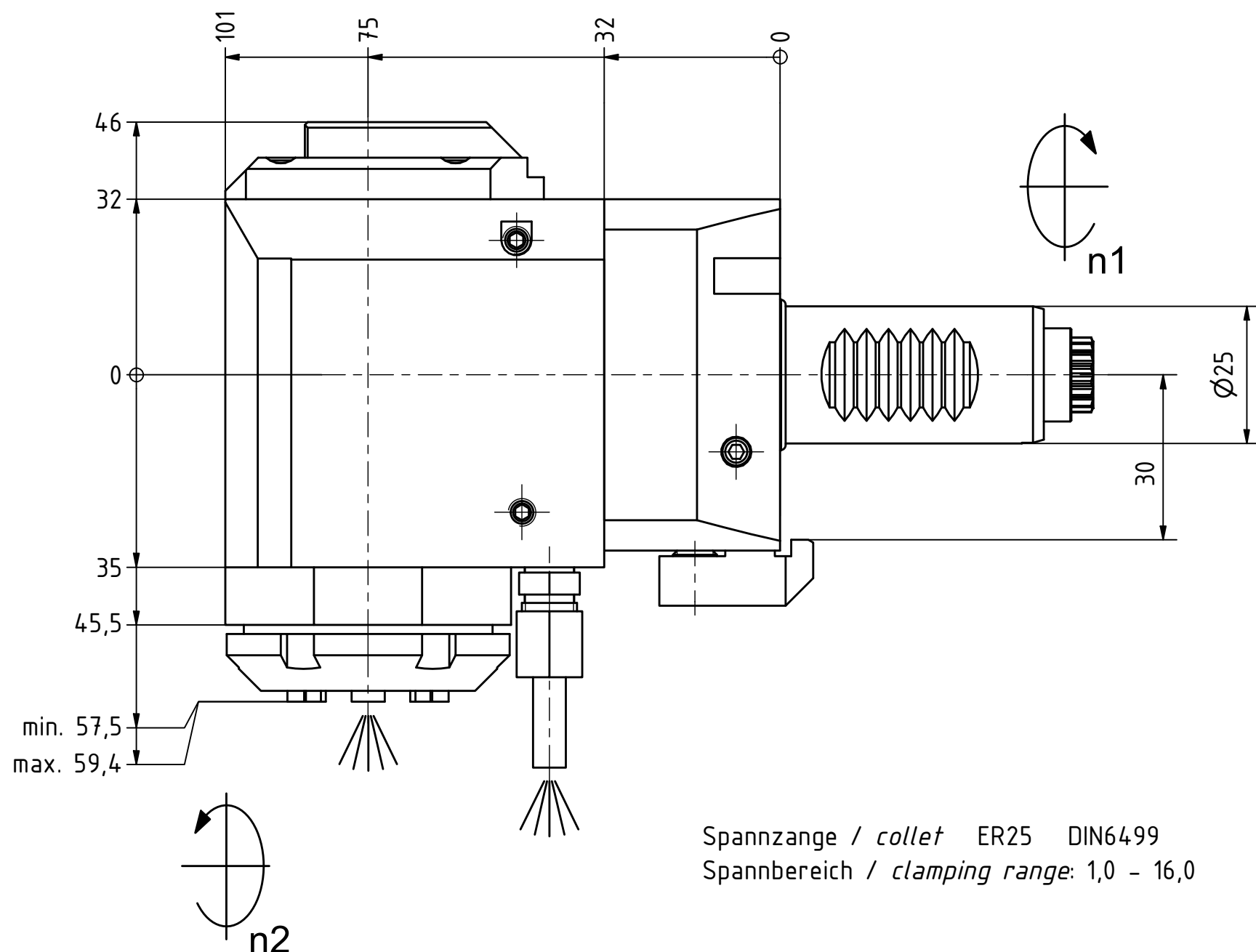

Tech Details



Spannzange / collet ER25 DIN6499
 Spannbereich / clamping range: 1,0 - 16,0

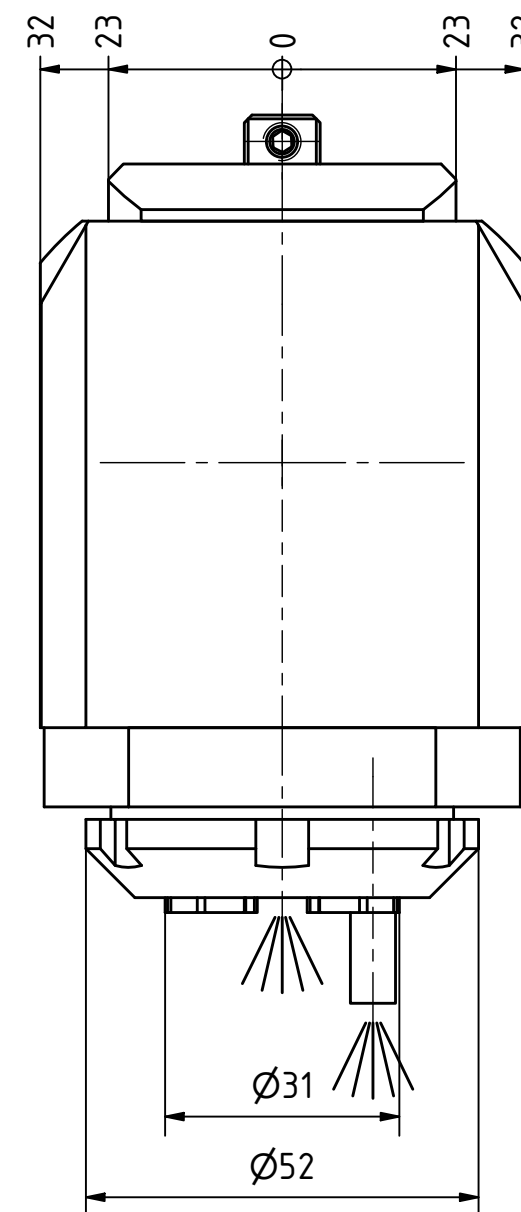

min. 57,5
 max. 59,4

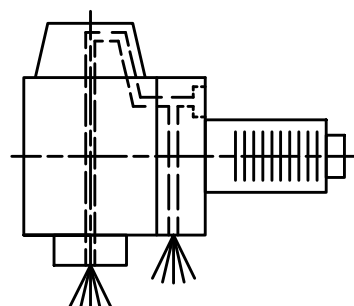
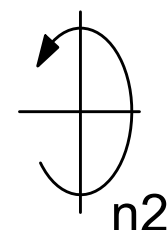

Innen- und Aussenkuehlung / Inside and outside coolant supply
 Kuehlmittelfiltrierung <math>< 50\mu</math> / coolant filtration <math>< 50\mu</math>

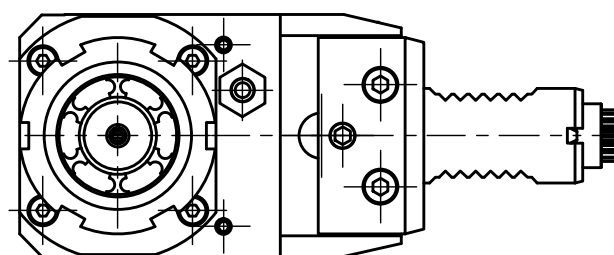

Doppelverzahnung Lizenz Traub
 double tooth system licence Traub

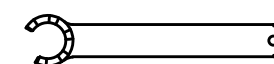
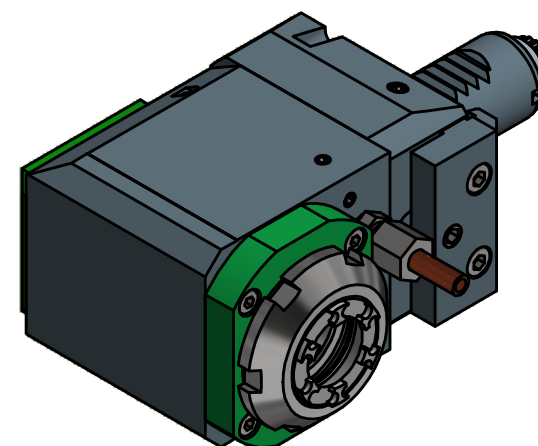

Spannzangenschlüssel für innenliegende Mutter
 Clamping wrench for internal collet
 225AX

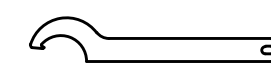

Hakenschlüssel mit Nase
 Hook wrench with nose end
 DIN1810 A 52x55

Copyright **EWS Tool Technologies**
 Weitergabe und Vervielfaeltigung dieser Unterlage, Verwertung und Mitteilung ihres Inhalts nicht gestattet, soweit nicht ausdrecklich zugestanden. Zuwiderhandlungen verpflichten zu Schadenersatz.

Bemerkung - Note
 Für Trockenlauf geeignet!
 Use without coolant fluid allowed!

Technische Daten - technical data	
Weight	= 3,374 [kg]
Torque max. (M1/M2)	= 25 / 25 [Nm]
Speed max. (n1/n2)	= 8000 / 8000 [1/min]
Gear ratio (i)=n1:n2	= 1:1
Pressure (pmax)	= 70 [bar]

Benennung - Title
Radial Bohr und Fräskopf
Radial drilling and milling head



Nr. - No.
60.2525E332RLIKDIM

Technische Aenderungen vorbehalten!
 Subject to technical modifications!

IDENT: DEWS139390

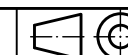

REV: -/A

MNR.

224572

