

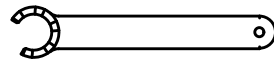

Ceramic Seal



Tech Details



Spannzangenschlüssel für innenliegende Mutter
Clamping wrench for internal collet
225AX

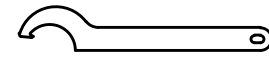

Hakenschlüssel mit Nase
Hook wrench with nose end
DIN1810 A 52x55

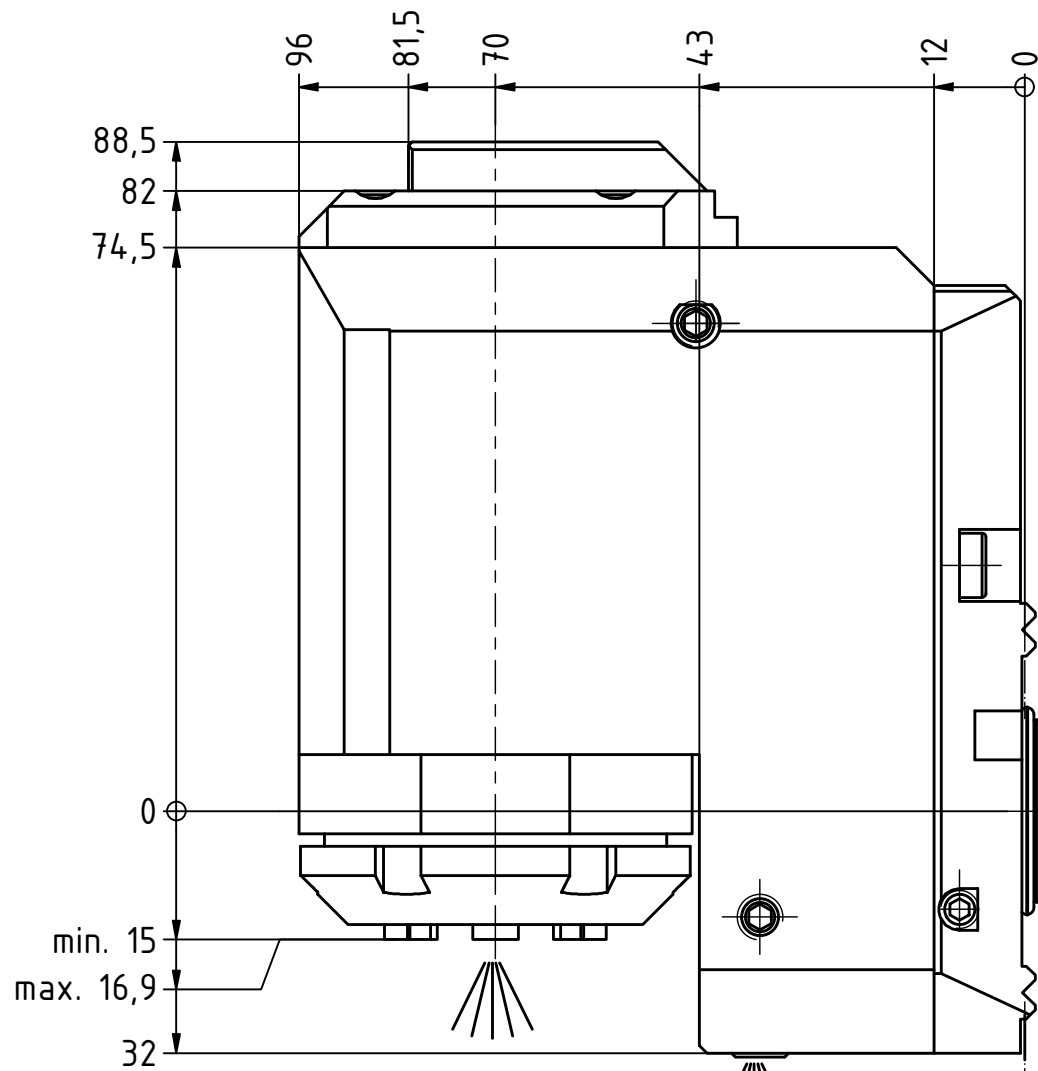

2 zurückgesetzte Werkzeuge können nicht nebeneinander platziert werden!
Einschränkung gilt nicht für C200!
2 radial drill. and mill.head with offset can not be used side by side!
Limitation does not apply to C200!

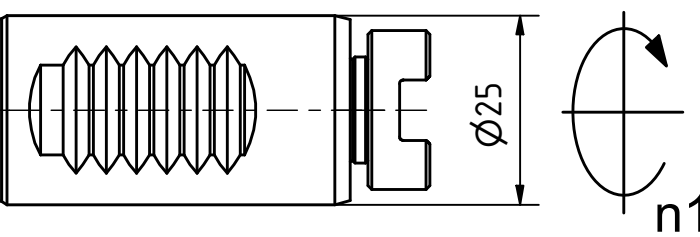

W-Verzahnung Lizenz Index-Werke
W-tooth system licence Index-Corporation

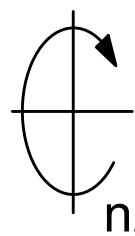
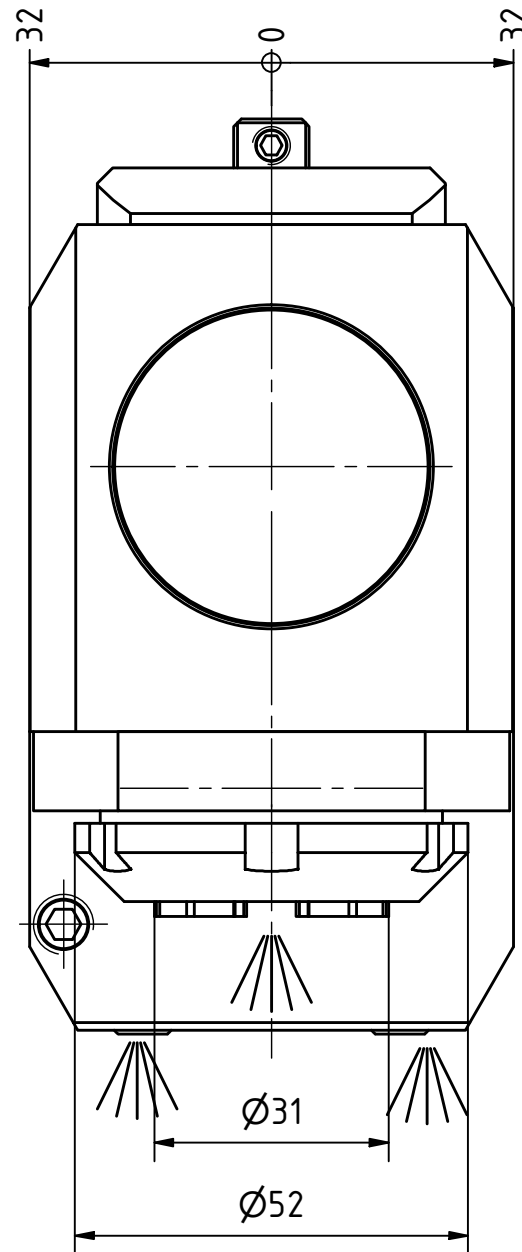

Spannzange / collet ER25 DIN6499
Spannbereich / clamping range: 1,0 - 16,0

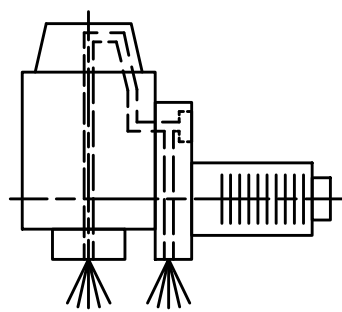

Innen- und Aussenkühlung / Inside and outside coolant supply
Kuehlmittelfiltrierung <50µ / coolant filtration <50µ

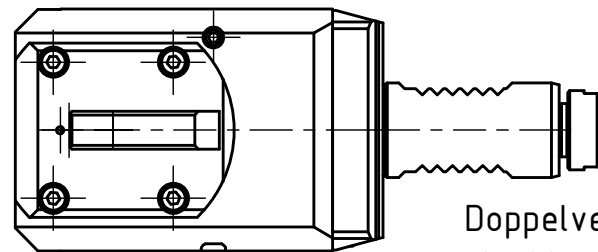

Doppelverzahnung Lizenz Traub
double tooth system licence Traub

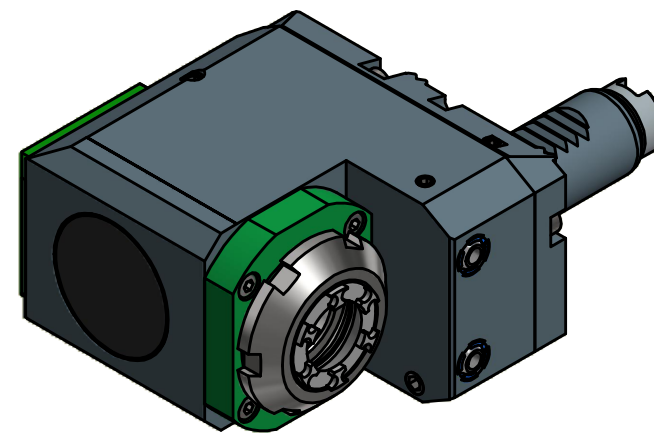

Copyright **EWS Tool Technologies**
Weitergabe und Vervielfaeltigung dieser Unterlage, Verwertung und Mitteilung ihres Inhalts nicht gestattet, soweit nicht ausdrecklich zugestanden. Zuwiderhandlungen verpflichten zu Schadenersatz.

Bemerkung - Note
Für Trockenlauf geeignet!
Use without coolant fluid allowed!

Technische Daten - technical data	
Weight	= 3.782 [kg]
Torque max. (M1/M2)	= 25 / 25 [Nm]
Speed max. (n1/n2)	= 8000 / 8000 [1/min]
Gear ratio (i)=n1:n2	= 1:1
Pressure (pmax)	= 70 [bar]

Benennung - Title
Radial Bohr und Fräskopf, zurückges
Radial drill. and mill. head offset



Technische Aenderungen vorbehalten!
Subject to technical modifications!
IDENT: DEWS138444

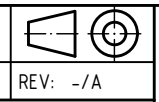

Nr. - No.
80.2525G200RLIKDWIM

REV: -/A
MNR.
224491

