

Butterfly Seal Polygon Joint Coolant Management Tech Details

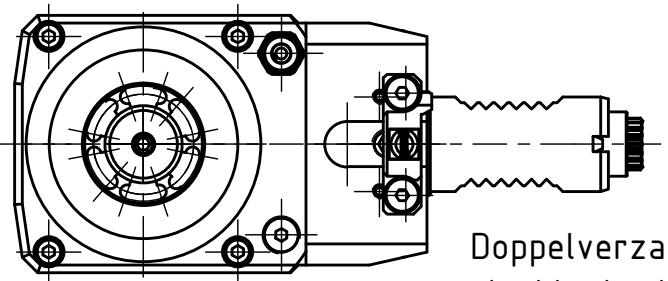

Doppelverzahnung Lizenz Traub  
double tooth system licence Traub

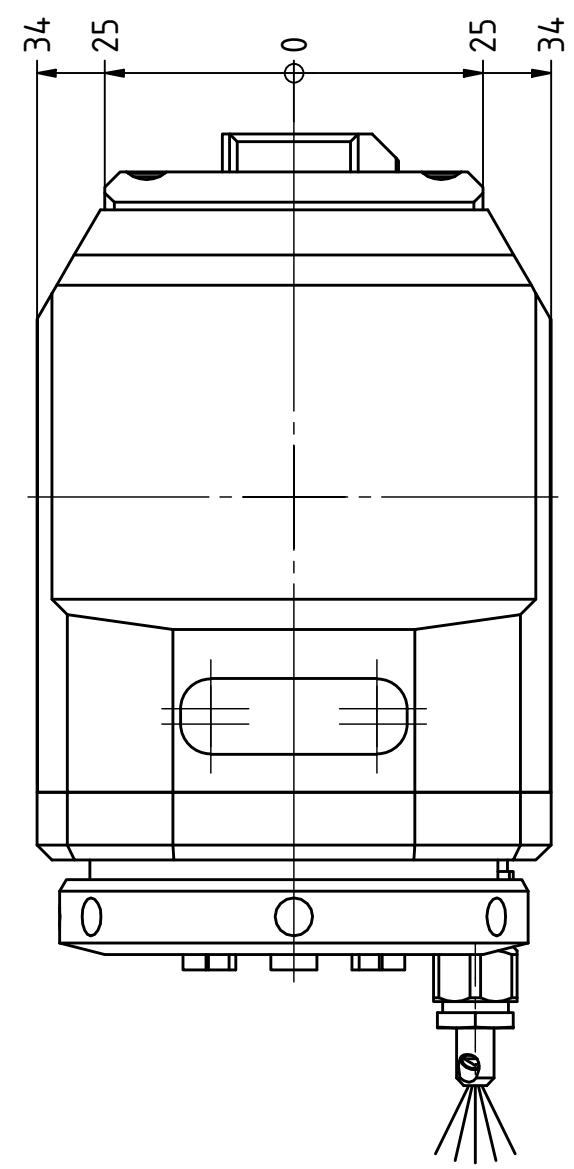
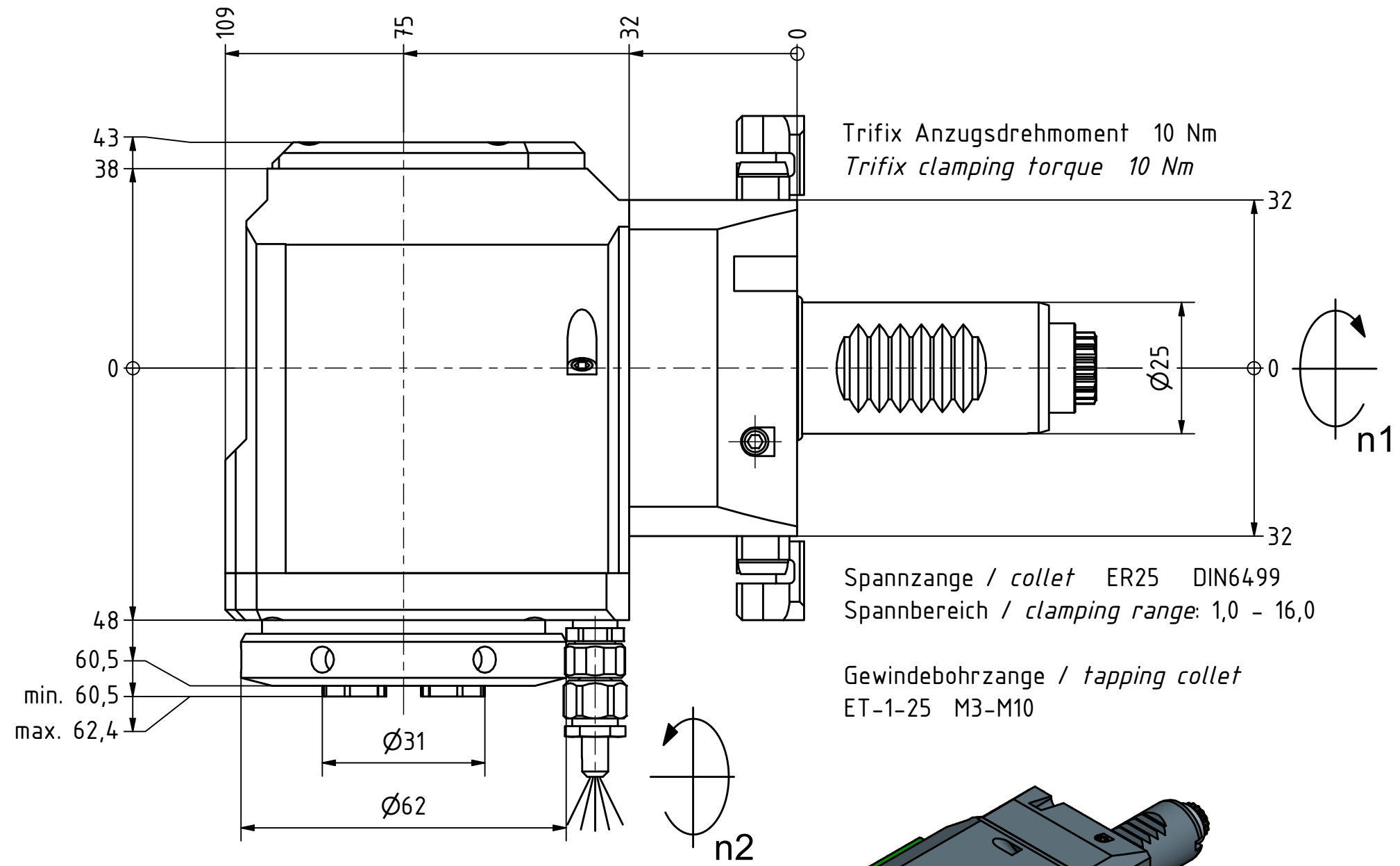
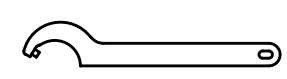
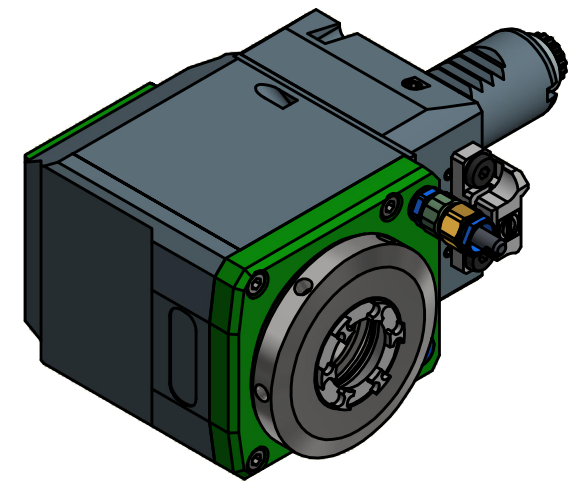

Hakenschlüssel  
mit Zapfen  
Hook wrench  
with fixed pin  
DIN1810 B 58x62

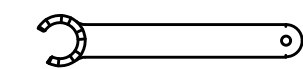

Spannzangenschlüssel für  
innenliegende Mutter  
Clamping wrench for  
internal collet  
225AX

Copyright **EWS Tool Technologies**  
Weitergabe und Vervielfältigung dieser Unterlage,  
Verwertung und Mitteilung ihres Inhalts nicht  
gestattet, soweit nicht ausdrücklich zugestanden.  
Zuwiderhandlungen verpflichten zu Schadenersatz.

Bemerkung - Note

Technische Daten - technical data

Weight	= 3.838 [kg]
Torque max. (M1/M2)	= 25 / 25 [Nm]
Speed max. (n1/n2)	= 8000 / 8000 [1/min]
Gear ratio (i)=n1:n2	= 1:1

Benennung - Title

**Radial Bohr und Fräskopf**  
**Radial drilling and milling head**

**EWS**  
Tool Technologies

EWS Weigele GmbH & Co. KG  
Maybachstr. 1  
D-73066 Uthingen  
www.ews-tools.de

Technische Änderungen vorbehalten!  
Subject to technical modifications!

IDENT: DEWS135839	REV: -/A
Nr. - No.	MNR.
<b>60.2525L5480RLTFRIM</b>	<b>224636</b>

