 Hakenschlüssel mit Zapfen
 Hook wrench with fixed pin
 DIN1810 B 68x75

 Spannzangenschlüssel für innenliegende Mutter
 Clamping wrench for internal collet
 232AX

Spannzange / collet ER32 DIN6499
 Spannbereich / clamping range: 2,0 - 20,0

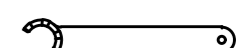
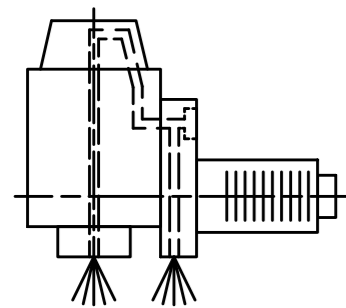

Innen- und Aussenkuehlung / Inside and outside coolant supply
 Kuehlmittelfiltrierung<50µ / coolant filtration<50µ

Copyright **EWS Tool Technologies**
 Weitergabe und Vervielfaeltigung dieser Unterlage, Verwertung und Mitteilung ihres Inhalts nicht gestattet, soweit nicht ausdrecklich zugestanden. Zuwiderhandlungen verpflichten zu Schadenersatz.

Bemerkung - Note Für Trockenlauf geeignet! Use without coolant fluid allowed!	Technische Daten - technical data Weight = 7.803 [kg] Torque max. (M1/M2) = 63 / 63 [Nm] Speed max. (n1/n2) = 6000 / 6000 [1/min] Gear ratio (i)=n1:n2 = 1:1 Pressure (pmax) = 70 [bar]	Benennung - Title Radial Bohr und Fräskopf, zurückges Radial drill. and mill. head offset	 EWS Weigle GmbH & Co. KG Maybachstr. 1 D-73066 Uhlingen www.ews-tool.de	Technische Aenderungen vorbehalten! Subject to technical modifications! IDENT: DEWS14.0080 REV: -/A MNR. 224808
---	--	---	--	---

