

Spannzange / collet ER25 DIN6499  
 Spannbereich / clamping range: 1,0 - 16,0

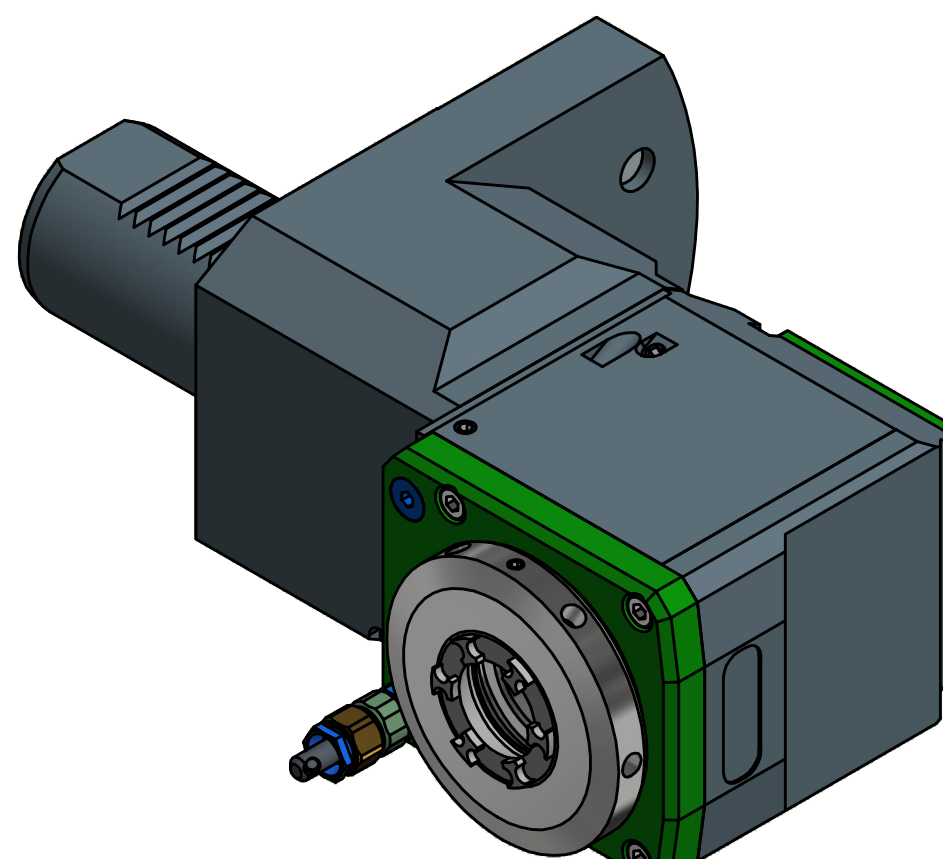

Gewindebohrzange / tapping collet  
 ET-1-25 M3-M12

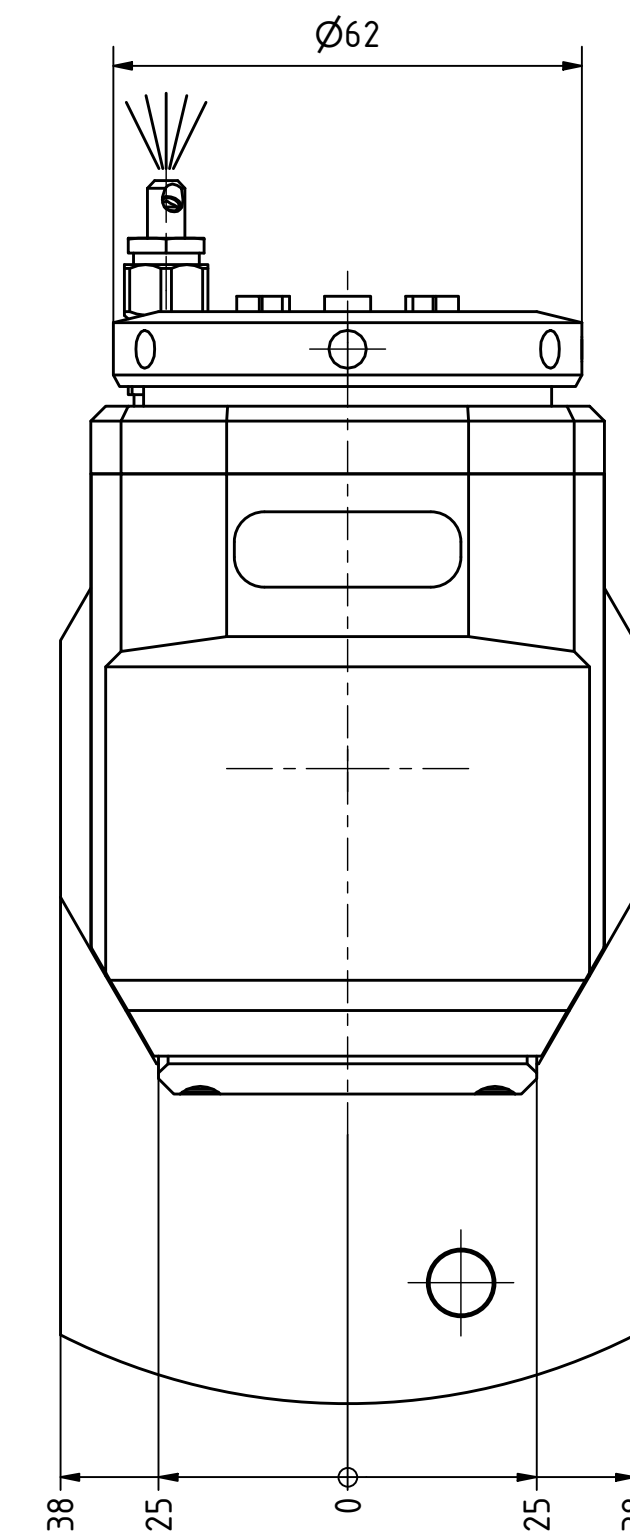
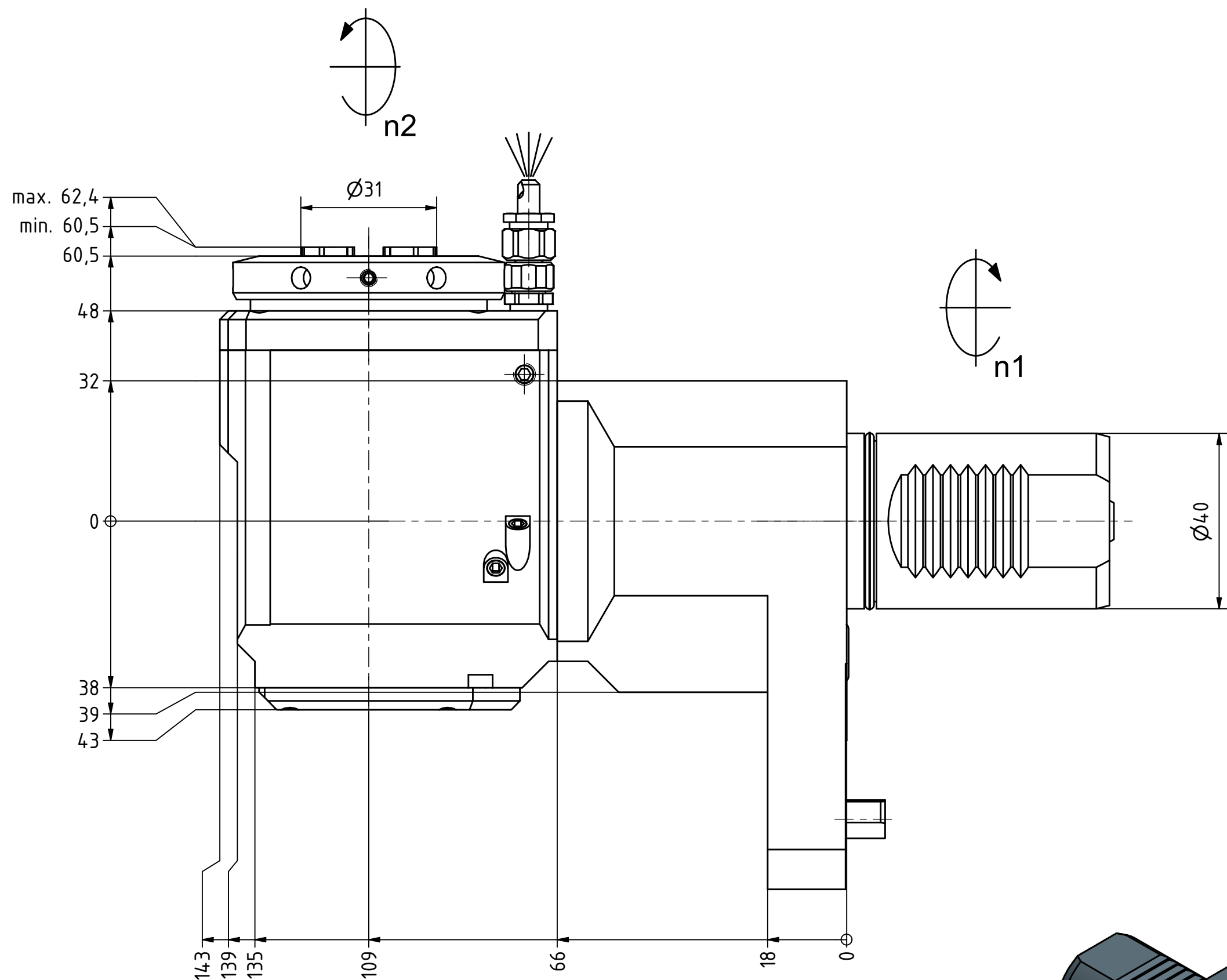
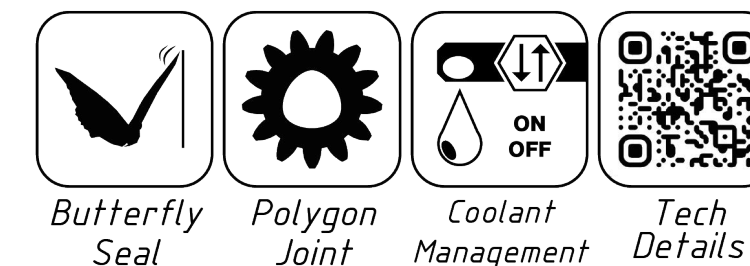
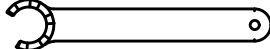
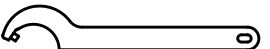

 Spannzangenschlüssel für innenliegende Mutter  
*Clamping wrench for internal collet*  
 225AX

 Hakenschlüssel mit Zapfen  
*Hook wrench with fixed pin*  
 DIN1810 B 58x62

Copyright **EWS Tool Technologies**  
 Weitergabe und Vervielfältigung dieser Unterlage,  
 Verwertung und Mitteilung ihres Inhalts nicht  
 gestattet, soweit nicht ausdrücklich zugestanden.  
 Zuwiderhandlungen verpflichten zu Schadenersatz.

Bemerkung - Note	Technische Daten - technical data Weight = 6.132 [kg] Torque max. (M1/M2) = 32 / 32 [Nm] Speed max. (n1/n2) = 6000 / 6000 [1/min] Gear ratio (i)=n1:n2 = 1:1	Benennung - Title <b>Radial Bohr und Fräskopf</b> <i>Radial drilling and milling head</i>	 <b>EWS</b> Weigle GmbH & Co. KG Maybachstr. 1 D-73066 Ulm/ingen www.ews-tools.de Nr. - No. <b>60.4025MP610LIM</b>	Technische Änderungen vorbehalten! Subject to technical modifications! IDENT: DEWS1394.98 MNR. <b>224777</b>	 <b>QR</b>
------------------	--	---	--	--	---