

Spannzange / collet ER25 DIN6499
Spannbereich / clamping range: 1,0 - 16,0

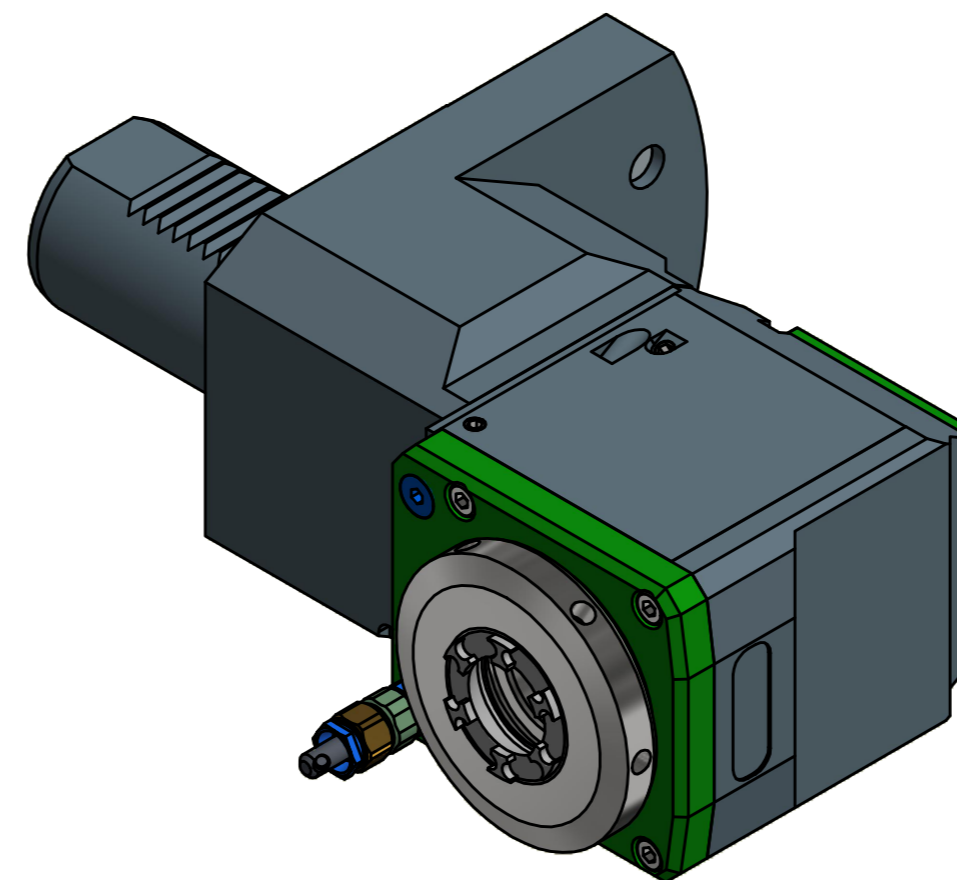

 Spannzangenschlüssel für innenliegende Mutter
Clamping wrench for internal collet
225AX

 Hakenschlüssel mit Zapfen
Hook wrench with fixed pin
DIN1810 B 58x62

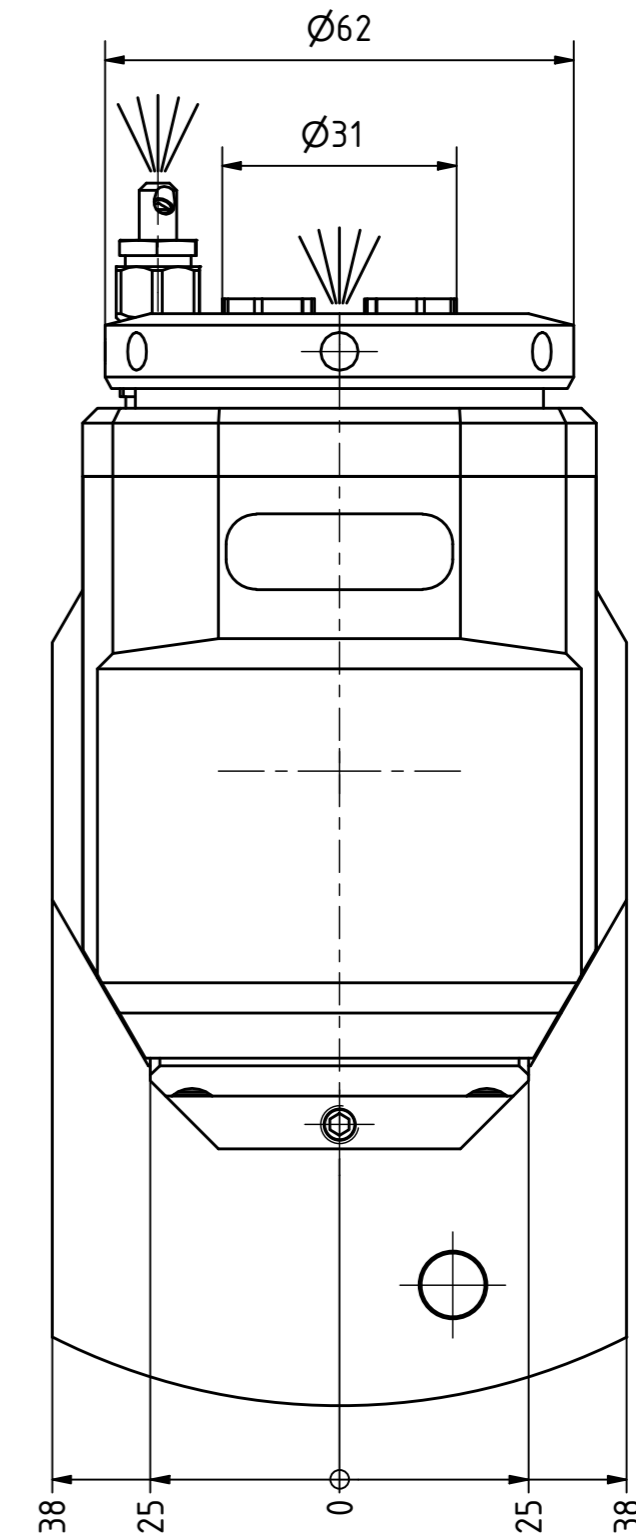
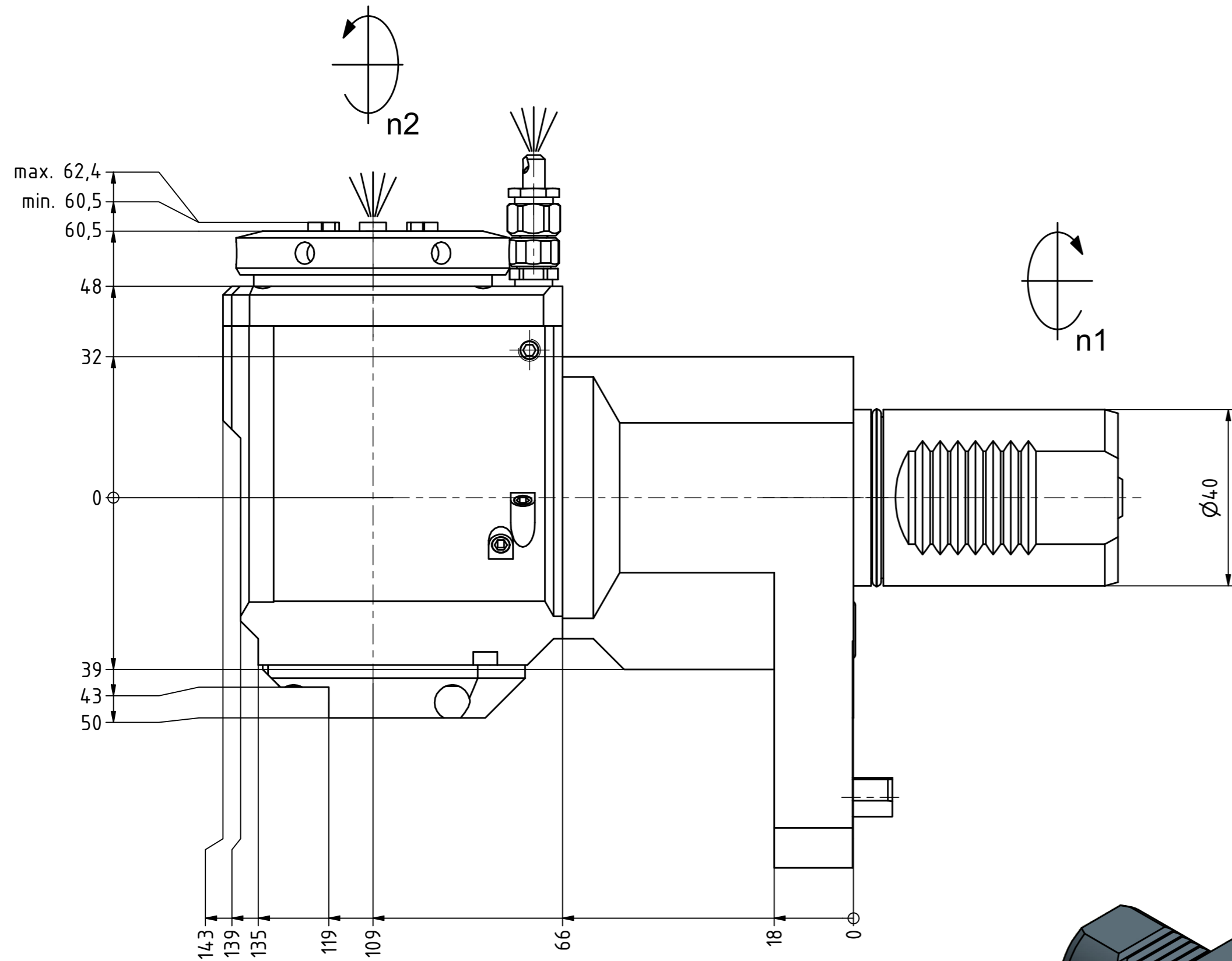
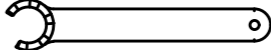
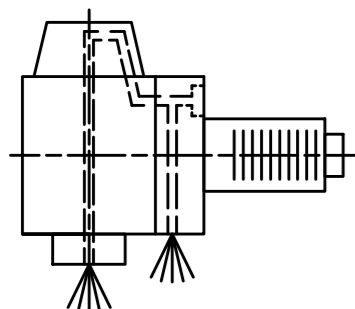

Innen- und Aussenkühlung / Inside and outside coolant supply
Kuehlmittelfiltrierung-50µ / coolant filtration-50µ

Copyright **EWS Tool Technologies**
Weitergabe und Vervielfaeltigung dieser Unterlage,
Verwertung und Mitteilung ihres Inhalts nicht
gestattet, soweit nicht ausdrecklich zugestanden.
Zuwoerhandlungen verpflichten zu Schadenersatz.

<p>Bemerkung - Note Für Trockenlauf geeignet! Use without coolant fluid allowed!</p>	<p>Technische Daten - technical data Weight = 6.231 [kg] Torque max. (M1/M2) = 32 / 32 [Nm] Speed max. (n1/n2) = 6000 / 6000 [1/min] Gear ratio (i)=n1:n2 = 1:1 Pressure (pmax) = 70 [bar]</p>	<p>Benennung - Title Radial Bohr und Fräskopf Radial drilling and milling head</p>	<p>EWS Tool Technologies EWS Weigle GmbH & Co. KG Maybachstr. 1 D-73066 Ulm/ingen www.ews-tools.de</p> <p>Technische Aenderungen vorbehalten! Subject to technical modifications! IDENT: DEWS139509 REV: -/A MNR. 224778</p>	<p>QR</p>
--	--	--	---	------------------