

Spannzange / collet ER32 DIN6499  
Spannbereich / clamping range: 2,0 - 20,0

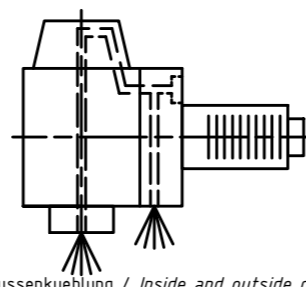

Innen- und Aussenkuehlung / Inside and outside coolant supply  
Kuehlmittelfiltrierung-50µ / coolant filtration-50µ

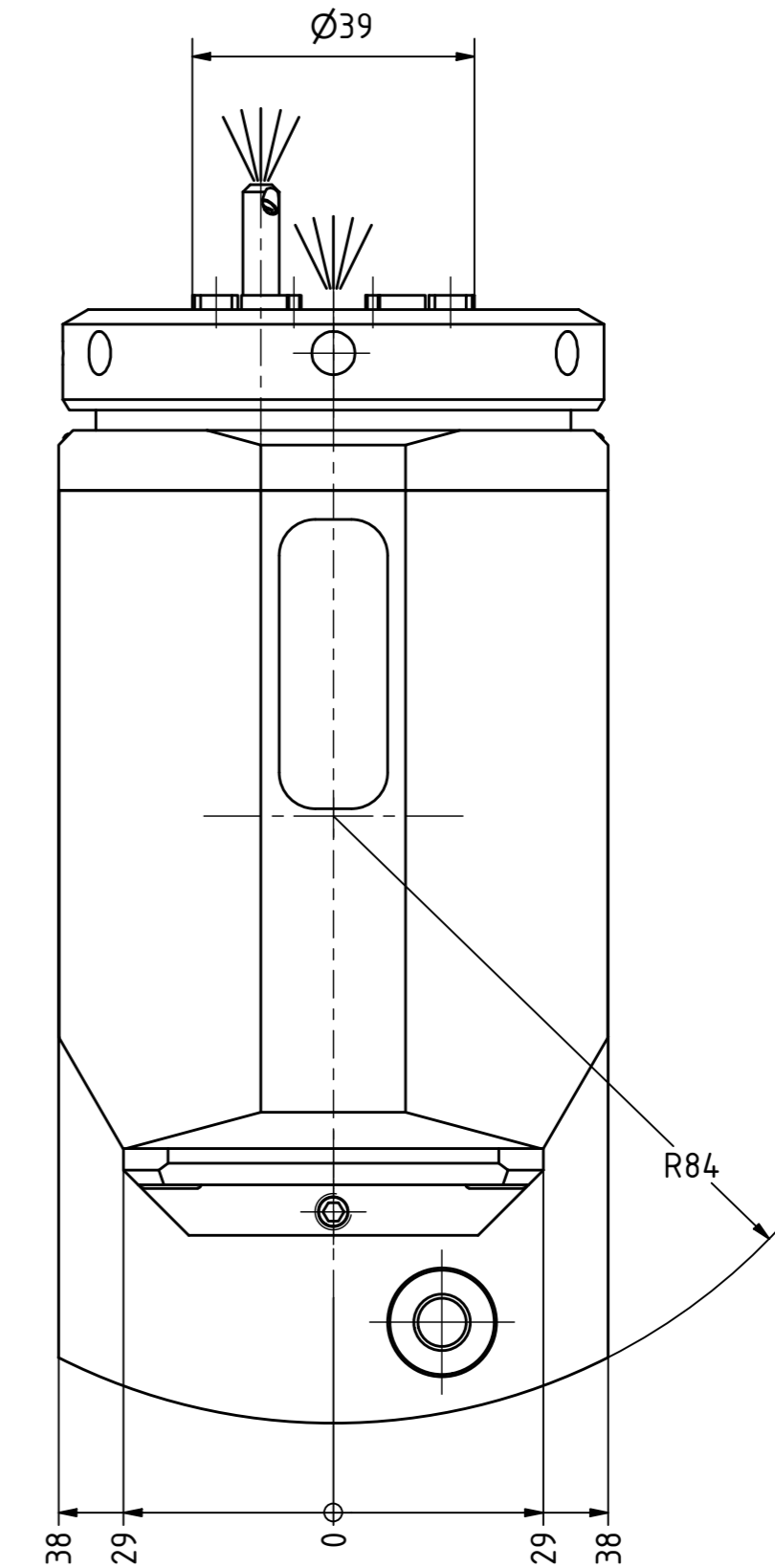
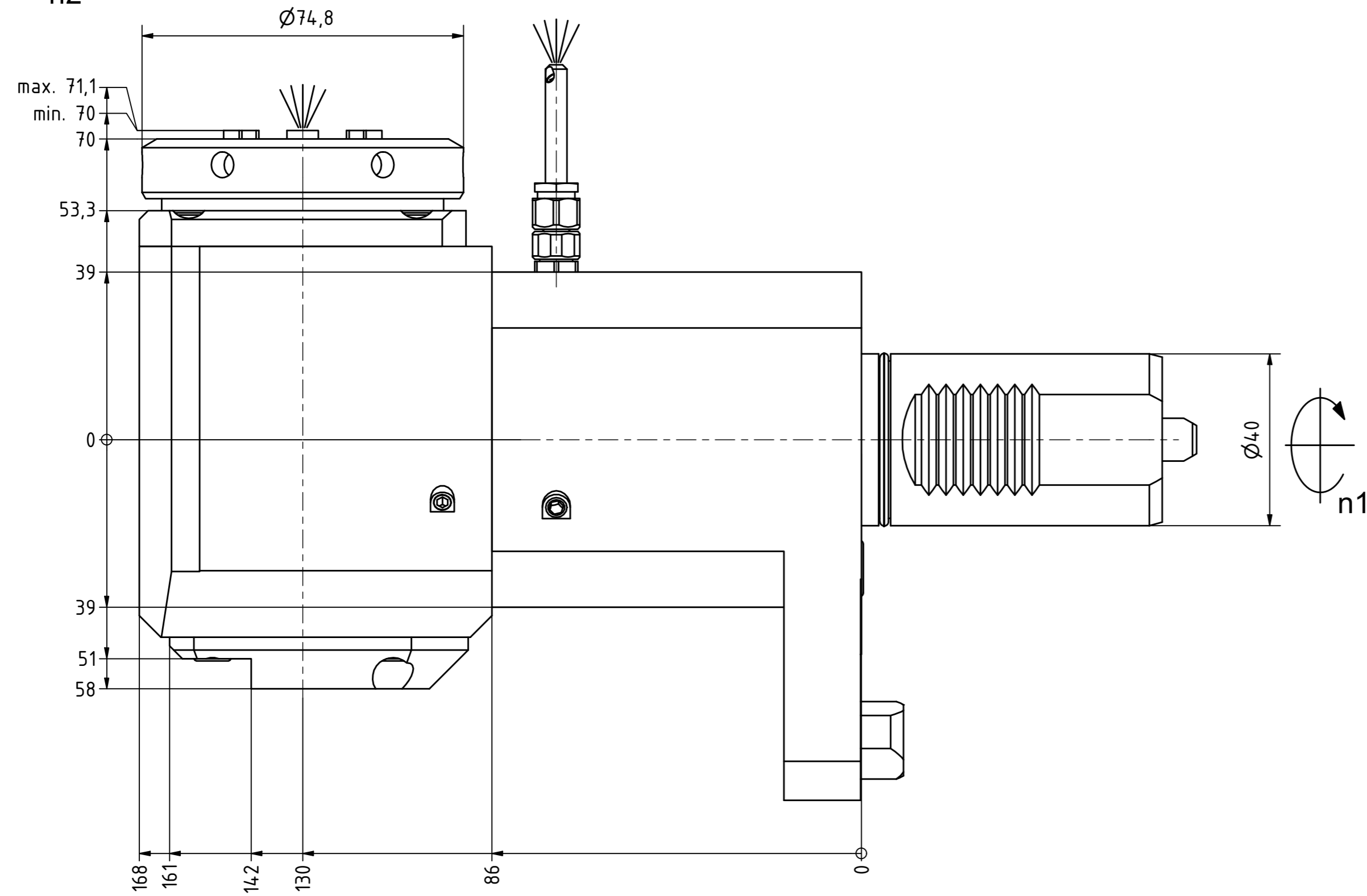
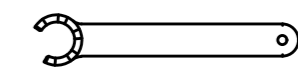
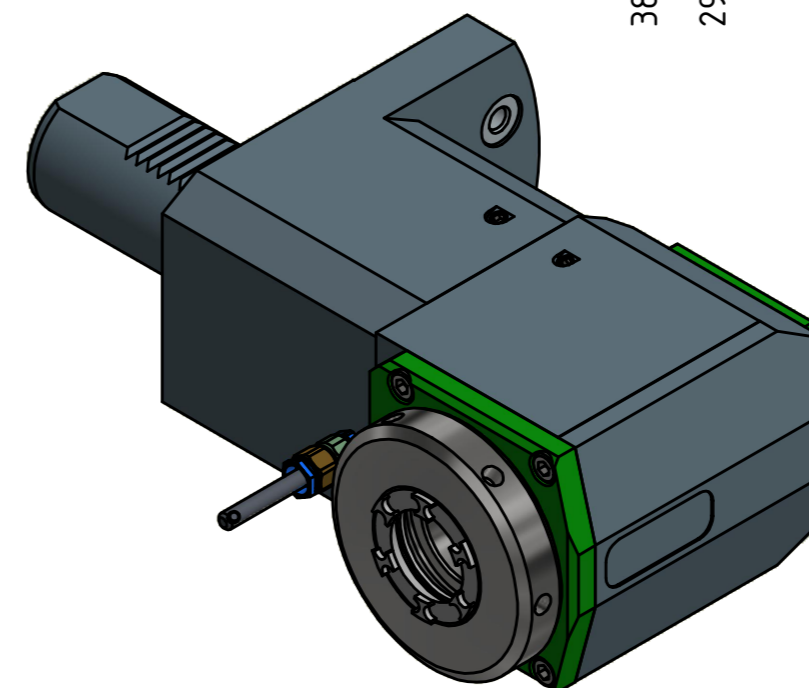

Spannzangenschlüssel für innenliegende Mutter  
Clamping wrench for internal collet  
232AX

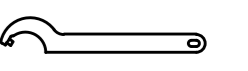

Hakenschlüssel mit Zapfen  
Hook wrench with fixed pin  
DIN1810 B 68x75

Copyright EWS Tool Technologies  
Weitergabe und Vervielfaeltigung dieser Unterlage, Verwertung und Mitteilung ihres Inhalts nicht gestattet, soweit nicht ausdruecklich zugestanden. Zuwiderhandlungen verpflichten zu Schadenersatz.

Bemerkung - Note  
Für Trockenlauf geeignet!  
Use without coolant fluid allowed!

Technische Daten - technical data  
Weight = 8.584 [kg]  
Torque max. (M1/M2) = 63 / 63 [Nm]  
Speed max. (n1/n2) = 6000 / 6000 [1/min]  
Gear ratio (i)=n1:n2 = 1:1  
Pressure (pmax) = [bar]

Benennung - Title  
Radial Bohr und Fräskopf  
Radial drilling and milling head



Nr. - No.  
60.4032MP620LIKDIM

Technische Aenderungen vorbehalten!  
Subject to technical modifications!  
IDENT: DEWS14.0222

REV: -/A  
MNR.  
224767

