

Spannzange / collet ER32 DIN6499  
Spannbereich / clamping range: 2,0 - 20,0

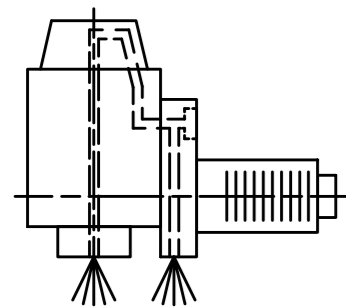

Innen- und Aussenkuehlung / Inside and outside coolant supply  
Kuehlmittelfiltrierung <math>50\mu</math> / coolant filtration <math>50\mu</math>

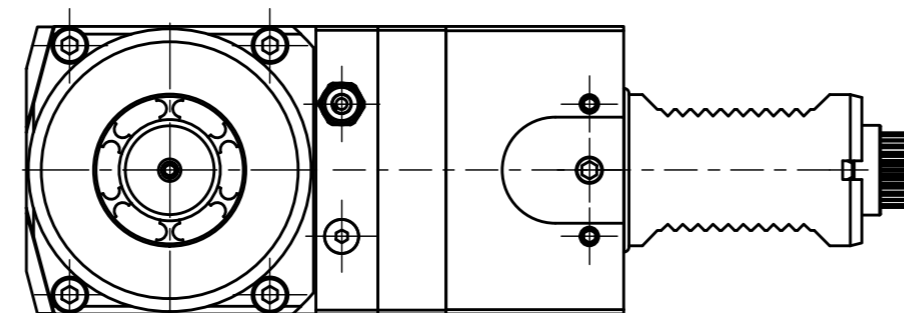

Doppelverzahnung Lizenz Traub  
double tooth system licence Traub

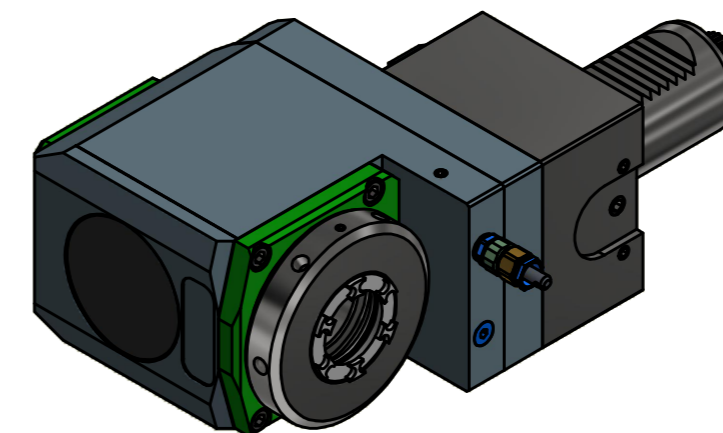

Hakenschlüssel mit Zapfen  
Hook wrench with fixed pin  
DIN1810 B 68x75

Spannzangenschlüssel für innenliegende Mutter  
Clamping wrench for internal collet  
232AX

Copyright EWS Tool Technologies  
Weitergabe und Vervielfaeltigung dieser Unterlage, Verwertung und Mitteilung ihres Inhalts nicht gestattet, soweit nicht ausdrecklich zugestanden. Zuwiderhandlungen verpflichten zu Schadenersatz.

Bemerkung - Note Für Trockenlauf geeignet! Use without coolant fluid allowed!	Technische Daten - technical data Weight = 8.468 [kg] Torque max. (M1/M2) = 63 / 63 [Nm] Speed max. (n1/n2) = 6000 / 6000 [1/min] Gear ratio (i)=n1:n2 = 1:1 Pressure (pmax) = 70 [bar]
---	--

Benennung - Title  
Radial Bohr und Fräskopf, zurückges  
Radial drill. and mill. head offset

<b>EWS</b> Tool Technologies	EWS Weigle GmbH & Co. KG Maybachstr. 1 D-73066 Uhlingen www.ews-tool.de	Technische Aenderungen vorbehalten! Subject to technical modifications! IDENT: DEWS151960	MNR. REV: -/C
Nr. - No. 80.4032LCTXRLIKDIM	224790		QR