

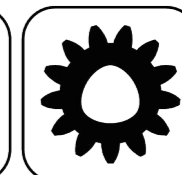

Ceramic Seal



Butterfly Seal



Polygon Joint



Tech Details

2 zurückgesetzte Werkzeuge können nicht nebeneinander platziert werden!
Einschränkung gilt nicht für C200!
2 radial drill. and mill.head with offset can not be used side by side!
Limitation does not apply to C200!

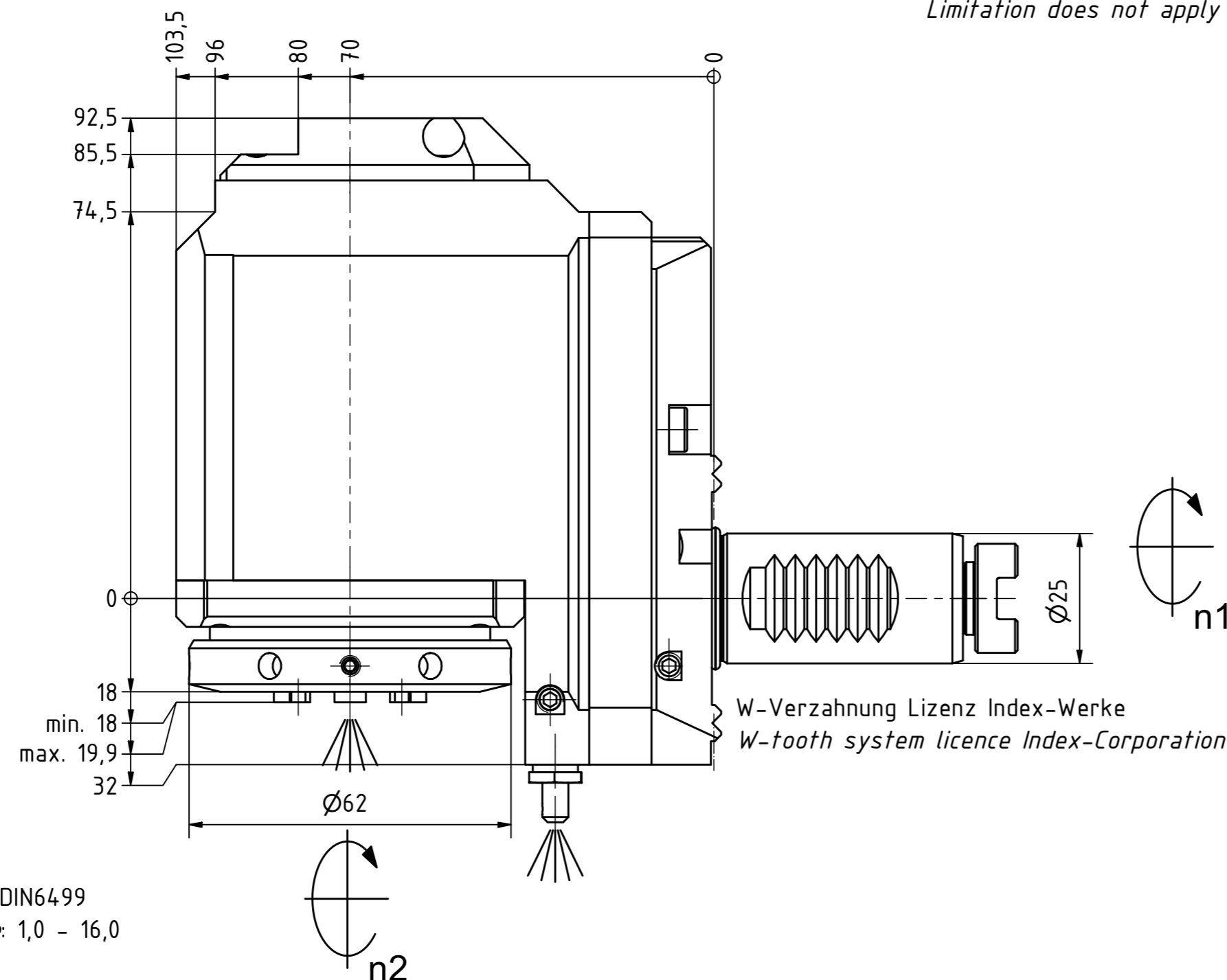

W-Verzahnung Lizenz Index-Werke
W-tooth system licence Index-Corporation

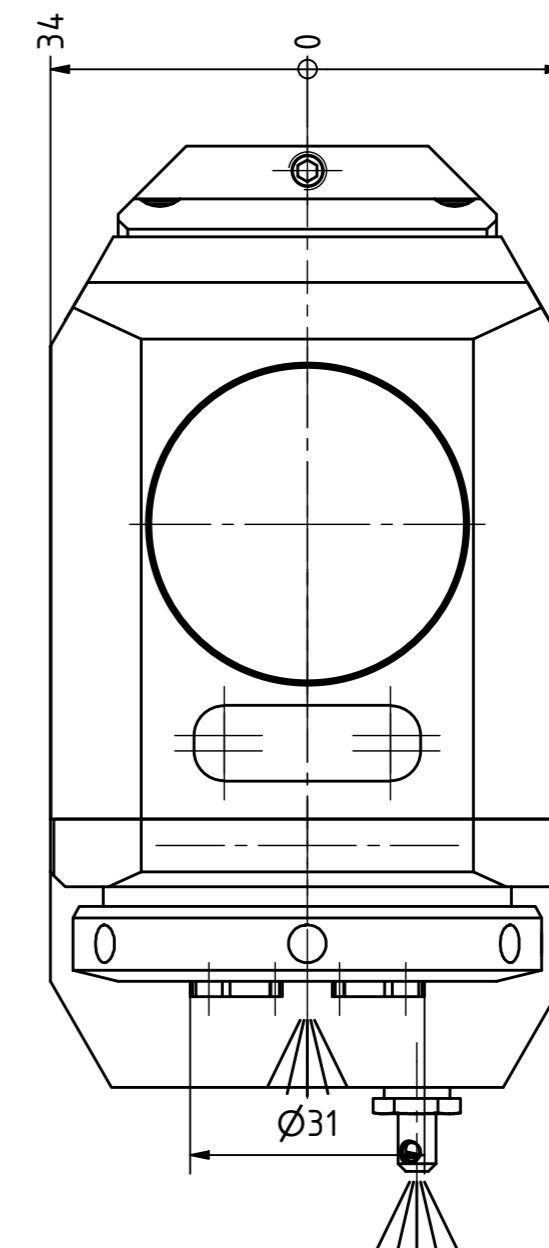

Spannzange / collet ER25 DIN6499
Spannbereich / clamping range: 1,0 - 16,0

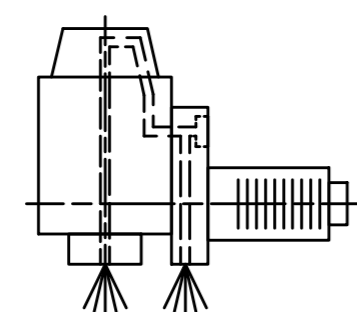

Innen- und Aussenkuehlung / Inside and outside coolant supply
Kuehlmittelfiltrierung-50 μ / coolant filtration-50 μ

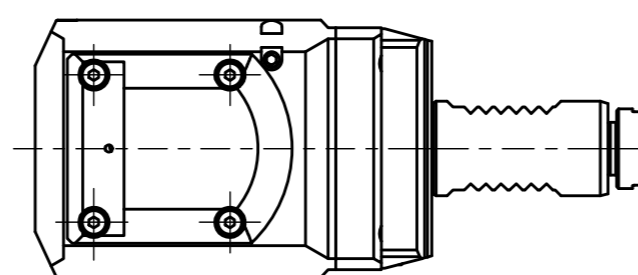

Doppelverzahnung Lizenz Traub
double tooth system licence Traub

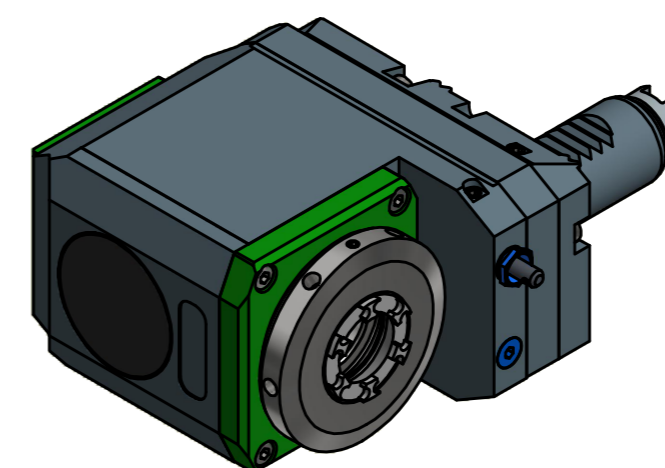

Hakenschlüssel mit Zapfen
Hook wrench with fixed pin
DIN1810 B 58x62

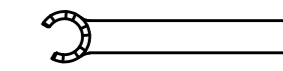

Spannzangenschlüssel für innenliegende Mutter
Clamping wrench for internal collet
225AX

Copyright EWS Tool Technologies
Weitergabe und Vervielfaeltigung dieser Unterlage, Verwertung und Mitteilung ihres Inhalts nicht gestattet, soweit nicht ausdrecklich zugestanden. Zuwiderhandlungen verpflichten zu Schadenersatz.

Bemerkung - Note Für Trockenlauf geeignet! Use without coolant fluid allowed!	Technische Daten - technical data Weight = 4,495 [kg]
	Torque max. (M1/M2) = 25 / 25 [Nm]
	Speed max. (n1/n2) = 8000 / 8000 [1/min]
	Gear ratio (i)=n1:n2 = 1:1
	Pressure (pmax) = 70 [bar]

Benennung - Title Radial Bohr und Fräskopf, zurückges Radial drill. and mill. head offset

EWS Tool Technologies <small>EWS Weigle GmbH & Co. KG Maybachstr. 1 D-73066 Ulm/geringen www.ews-tools.de</small>	Technische Aenderungen vorbehalten! Subject to technical modifications! IDENT: DEWS14.0322	REV: -/A MNR. 224787
Nr. - No. 80.2525G200RLIKDWIM#01		

