

2 zurückgesetzte Werkzeuge  
können nicht nebeneinander platziert werden!  
Einschränkung gilt nicht für C200!  
2 radial drill. and mill.head with offset  
can not be used side by side!  
Limitation does not apply to C200!

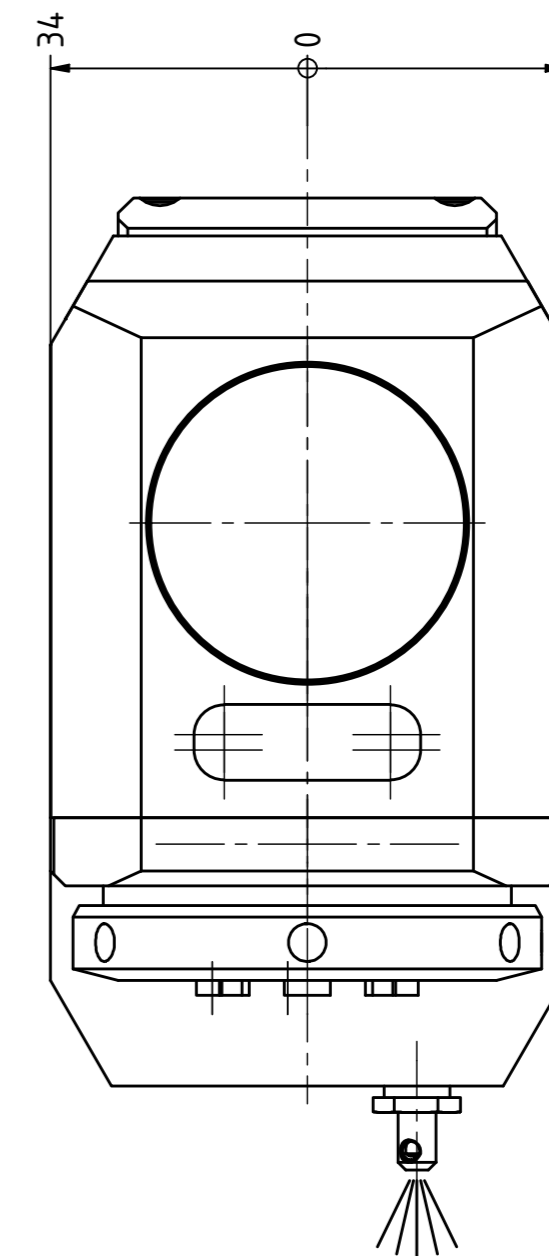

Spannzange / collet ER25 DIN6499  
Spannbereich / clamping range: 1,0 - 16,0

Gewindebohrzange / tapping collet  
ET-1-25 M3-M12

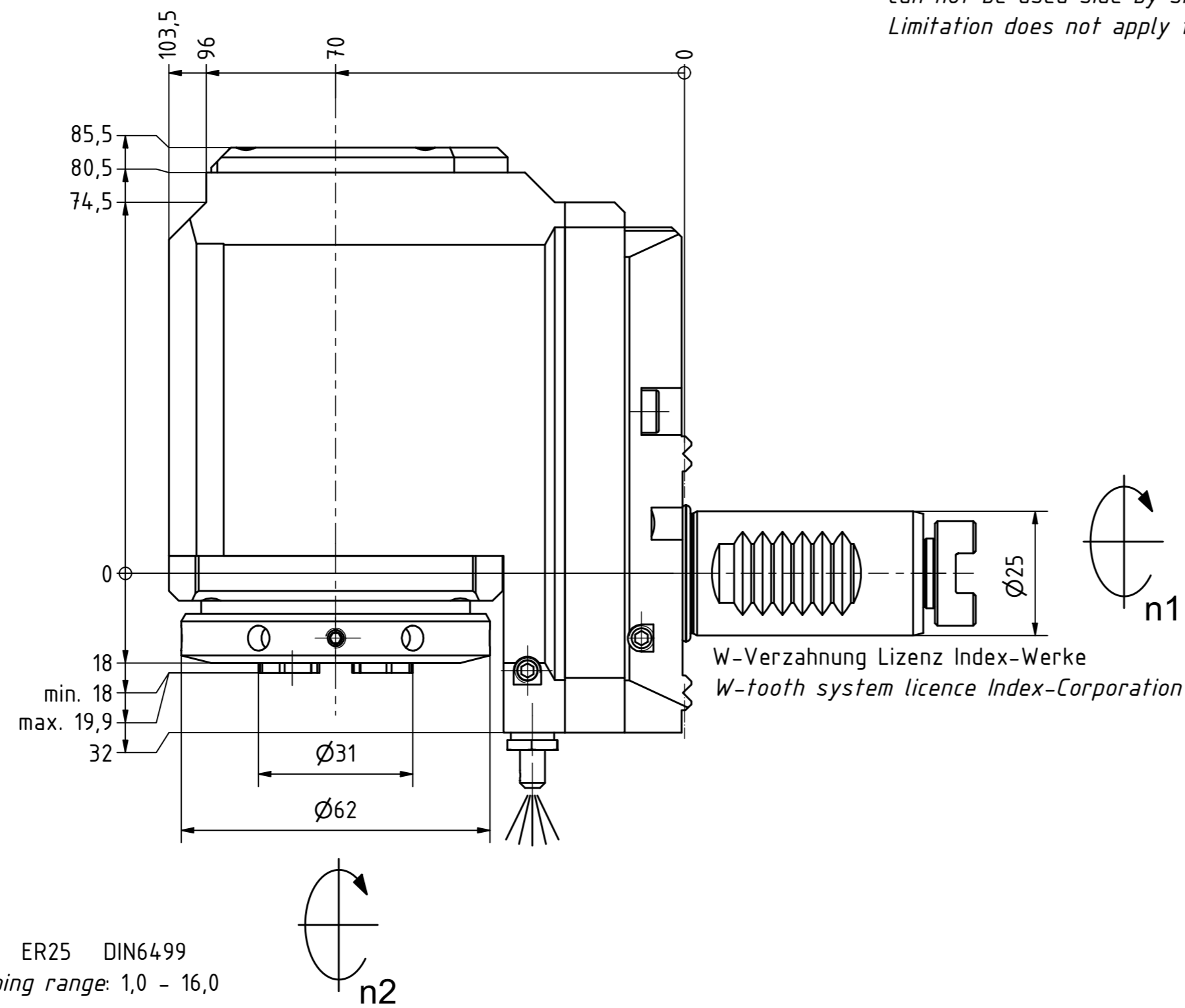
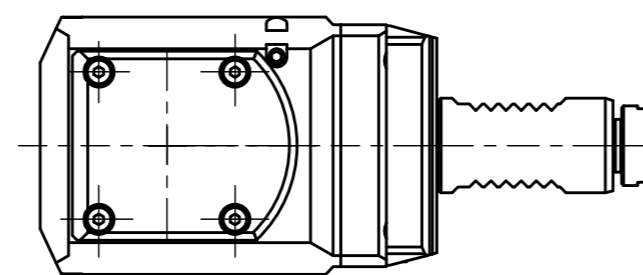

Doppelverzahnung Lizenz Traub  
double tooth system licence Traub

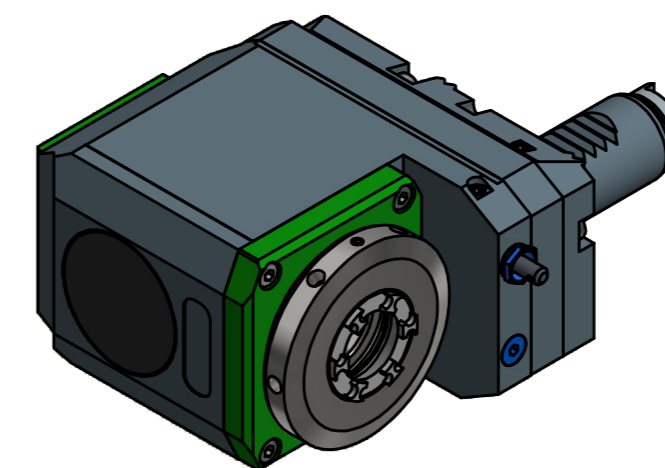



Hakenschlüssel  
mit Zapfen  
Hook wrench  
with fixed pin  
DIN1810 B 58x62



Spannzangenschlüssel für  
innenliegende Mutter  
Clamping wrench for  
internal collet  
225AX

Copyright EWS Tool Technologies  
Weitergabe und Vervielfältigung dieser Unterlage,  
Verwertung und Mitteilung ihres Inhalts nicht  
gestattet, soweit nicht ausdrücklich zugestanden.  
Zu widerhandlungen verpflichten zu Schadenersatz.

Bemerkung - Note	Technische Daten - technical data Weight = 4,397 [kg] Torque max. (M1/M2) = 25 / 25 [Nm] Speed max. (n1/n2) = 8000 / 8000 [1/min] Gear ratio (i)=n1:n2 = 1:1	Benennung - Title <b>Radial Bohr und Fräskopf, zurückges</b> <b>Radial drill. and mill. head offset</b>	 EWS Weigle GmbH & Co. KG Maybachstr. 1 D-73066 Uhingen www.ews-tools.de Technische Änderungen vorbehalten! Subject to technical modifications! IDENT: DEWS14.0333 Nr. - No. <b>80.2525G200RLWIM#01</b> MNR. <b>224788</b>	
------------------	--	---	---	---