

Kühlmittelzufuhr
coolant supply

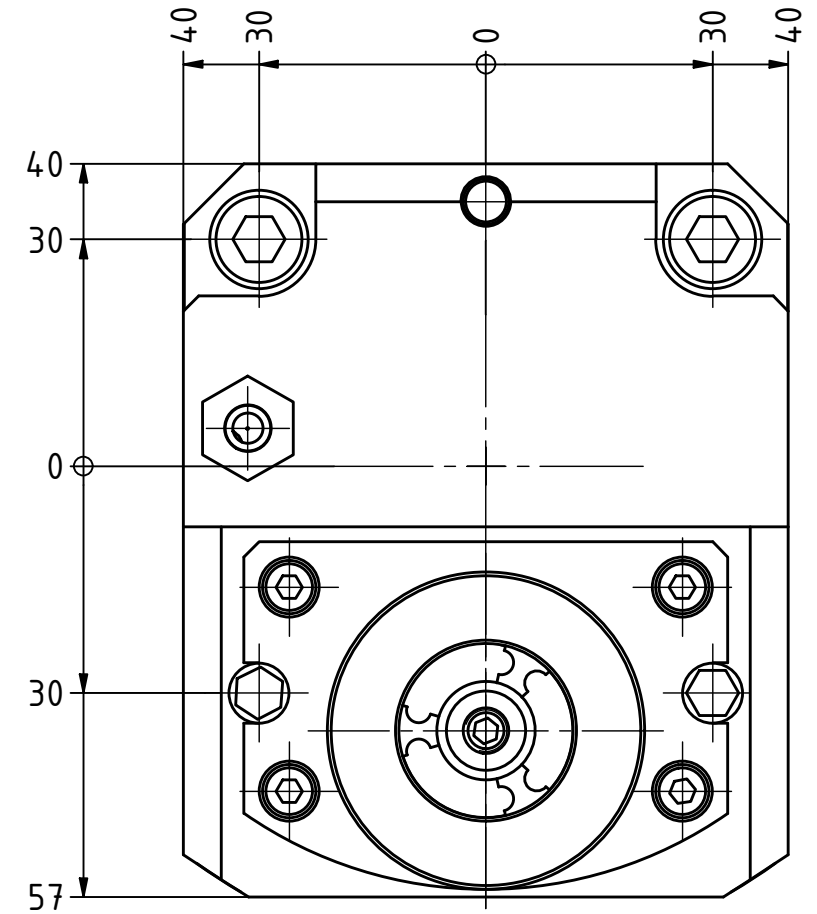

Spannzange / Collet ER16 DIN6499
Spannbereich / Clamping range: 1,0 - 10,0

Gewindebohrzange / Tapping Collet
ET-1-16 M1-M6

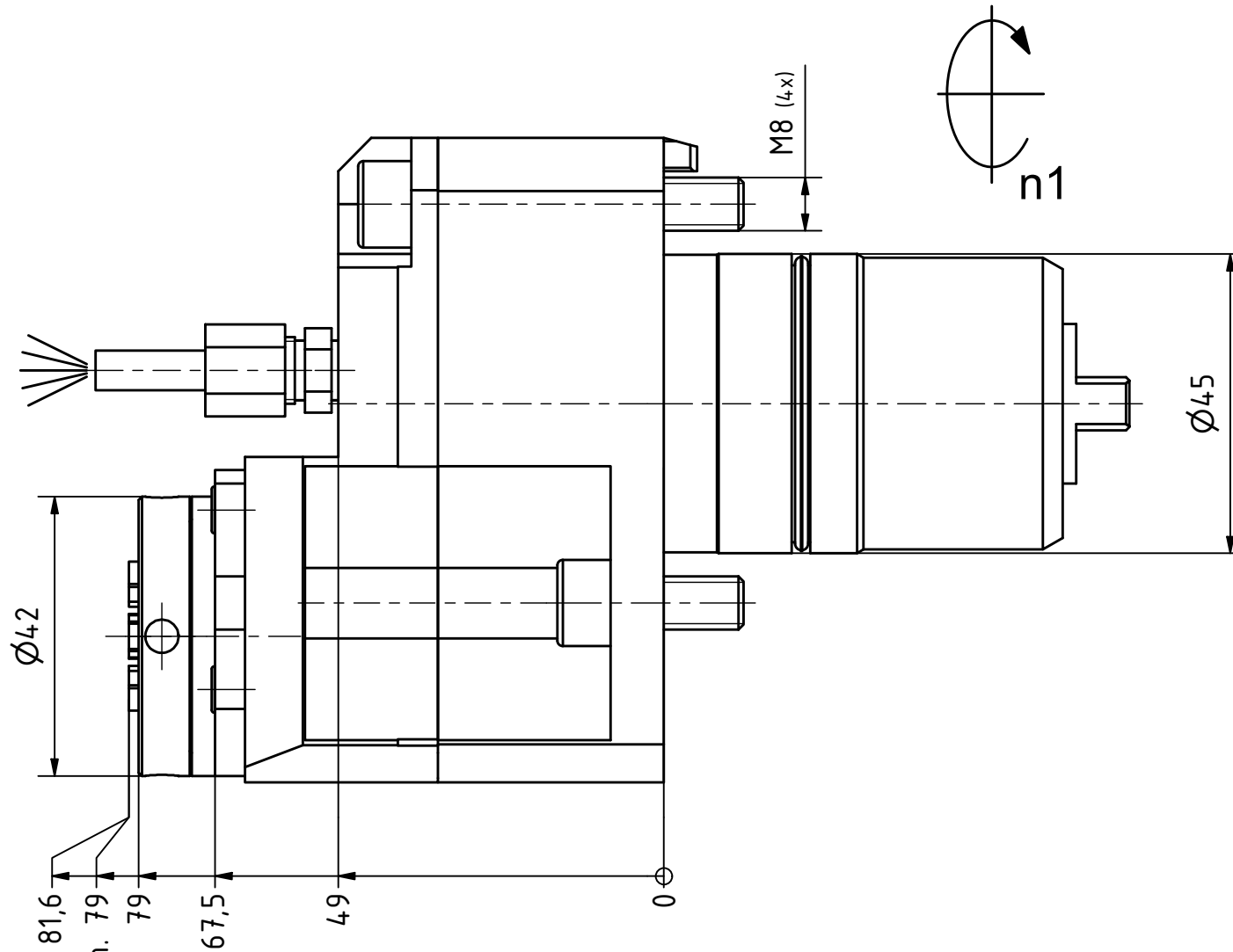
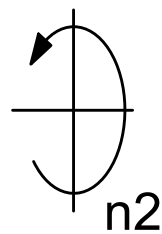
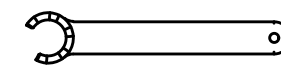
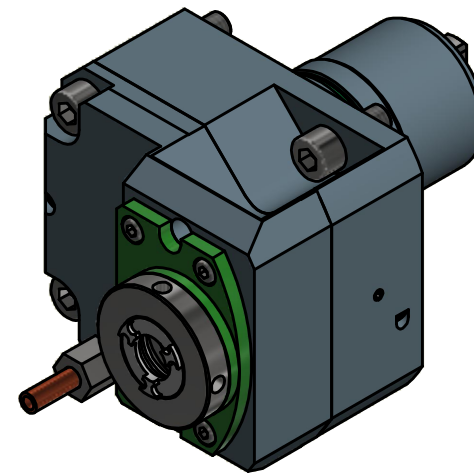

Spannzangenschlüssel für
innenliegende Mutter
Clamping wrench for
internal collet
216AX

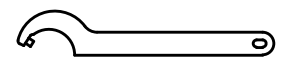

Hakenschlüssel
mit Zapfen
Hook wrench
with fixed pin
DIN1810 B 40x42

Copyright **EWS Tool Technologies**
Weitergabe und Vervielfältigung dieser Unterlage,
Verwertung und Mitteilung ihres Inhalts nicht
gestattet, soweit nicht ausdrücklich zugestanden.
Zuwendungen verpflichten zu Schadenersatz.

Bemerkung - Note

Technische Daten - technical data

Weight = 3.517 [kg]
Torque max. (M1/M2) = 15 / 5 [Nm]
Speed max. (n1/n2) = 6000 / 18000 [1/min]
Gear ratio (i)=n1:n2 = 1:2,89

Benennung - Title

Axial Bohr u. Fräskopf achsversetzt
Ax. drill. and mill. head offset



Nr. - No.
50.4516FX600R113IM

Technische Änderungen vorbehalten!
Subject to technical modifications!

IDENT: DEWS091381

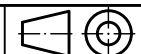

REV: -/A

MNR.

216865

