

max. Fraeserdurchmesser $\varnothing 100$
max. saw milling diameter

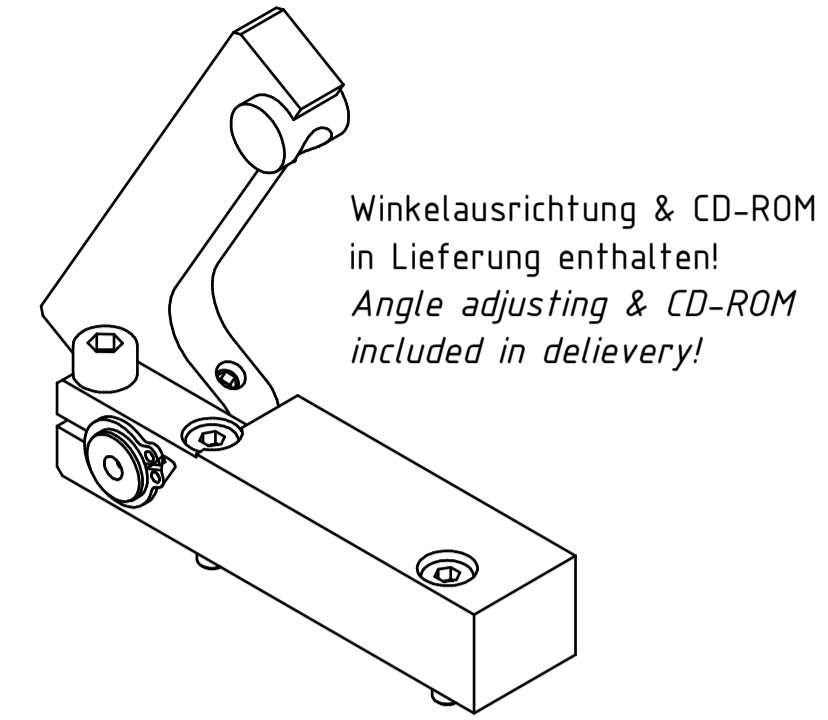

Winkelausrichtung & CD-ROM
in Lieferung enthalten!
Angle adjusting & CD-ROM
included in delivery!

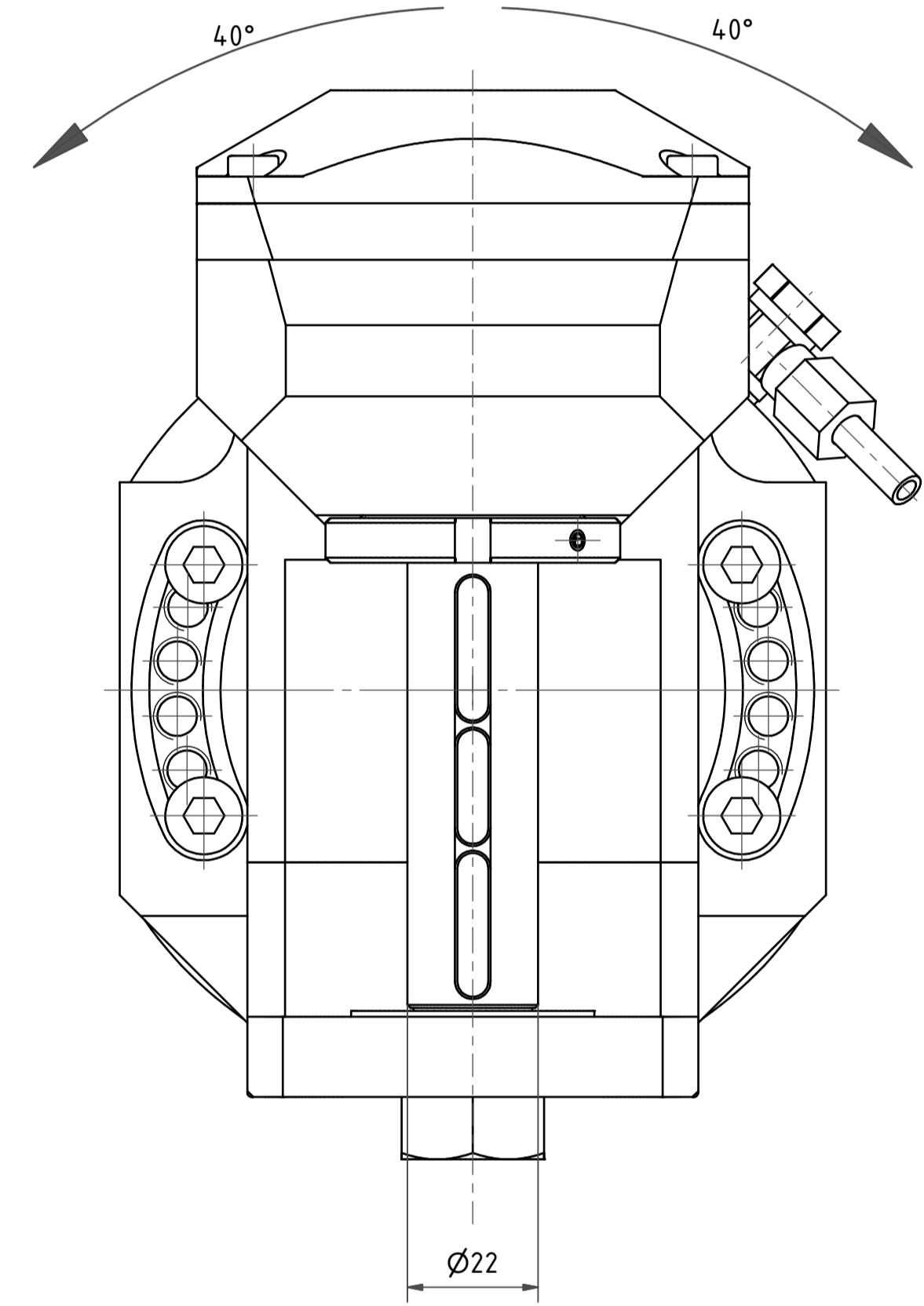

min. und max. Schwenkwinkel beziehen sich auf den Werkzeughalter.
Zusätzlich muss eine Kollisionsbetrachtung im Arbeitsraum durchgeführt werden!
*min. and max. swiveling angle refer to the tool
in addition the work space of the machine has to be checked for interferences!*

Beide Nachbarstationen nicht verwendbar!
both neighboring are not useable!

Fraeserwelle austauschbar
spindle removable

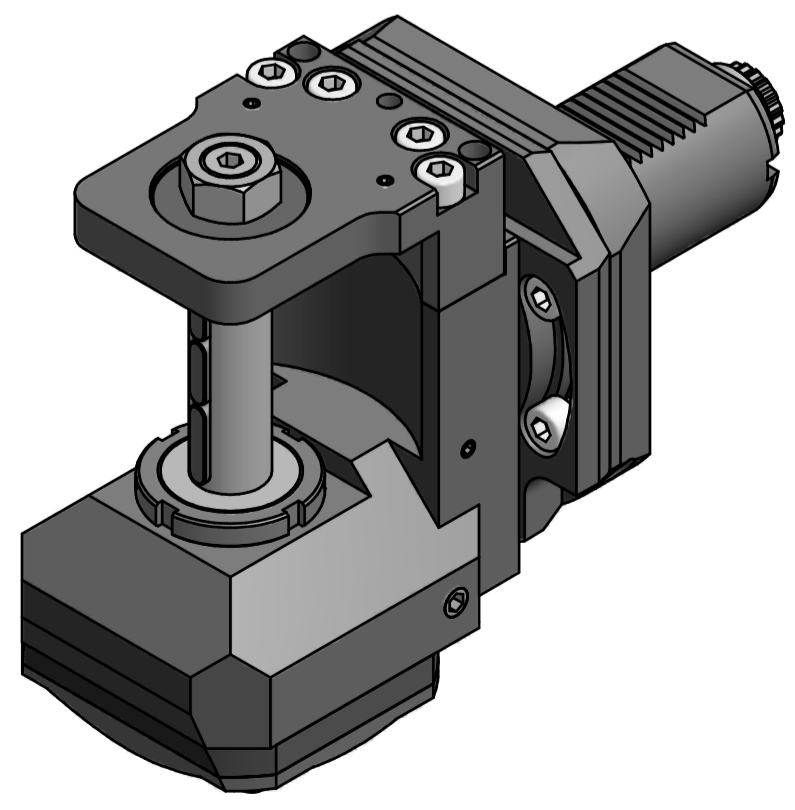

Bemerkung - Note	Technische Daten - Technical data	Benennung - Title		name	date	Technische Änderungen vorbehalten! Subject to technical modifications!	
	M1 / M2 = 50 / 150 Nm n1 / n2 = 6000 / 2000 1/min i (N1:N2) = 3:1	Scheibenfräserkopf Radial saw milling head					11.11.2008
				EWS	EWS Werkzeug GmbH & Co. KG Hauptstraße 7 D-75048 Ohligsen Tel. +49(0)71412044-100	64.5022548013TKWMB75	DIN A1
						MNR: 144316	IDENT: D-EWS-068589 - Blatt - page 1 (1)