

Der Ausrichtklotz ist beidseitig über einen Exzenter einstellbar.
The block is adjustable for both sides via eccentric.

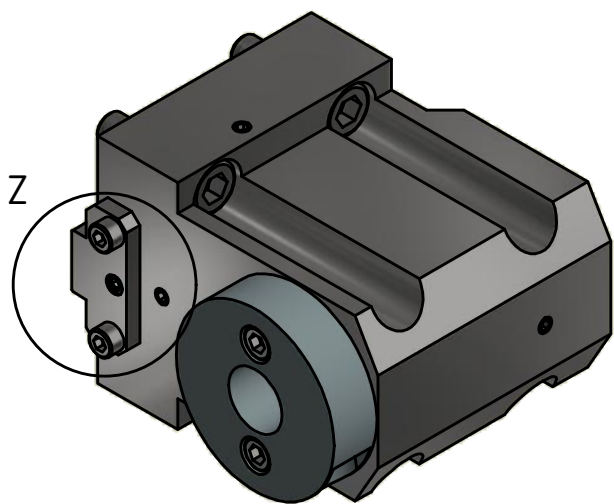

Hydrodehnfutter / hydraulic chuck NBC-20/25-46

Hülsen / collets 28.20xxHYDSP

XX (Ø) 3 4 5 6 7 8 9 10 12 14 16
 1/8 3/16 1/4 5/16 3/8 7/16 1/2 9/16 5/8

Copyright **EWS Tool Technologies**
 Weitergabe und Vervielfältigung dieser Unterlage, Verwertung und Mitteilung ihres Inhalts nicht gestattet, soweit nicht ausdrücklich zugestanden. Zuwiderhandlungen verpflichten zu Schadenersatz.

Bemerkung - Note

Technische Daten - technical data	Weight = 4.058 [kg]
-----------------------------------	---------------------

Benennung - Title	Bohrstangenhalter Boring bar holder
-------------------	--

EWS Tool Technologies	EWS Weigle GmbH & Co. KG Maybachstr. 1 D-73066 Utingen www.ews-tools.de
Nr. - No.	19.BMT20HYDWT250-AJ

Technische Änderungen vorbehalten! Subject to technical modifications!	IDENT: DEWS085749
REV: -/A	MNR. 215017

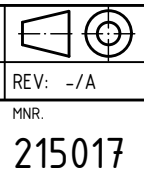

QR