

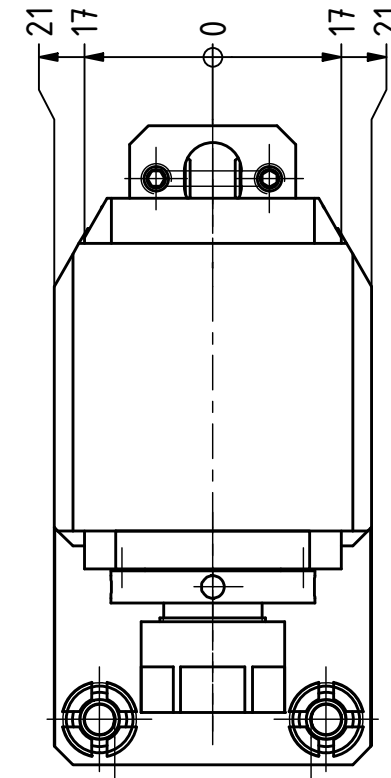

Highspeed

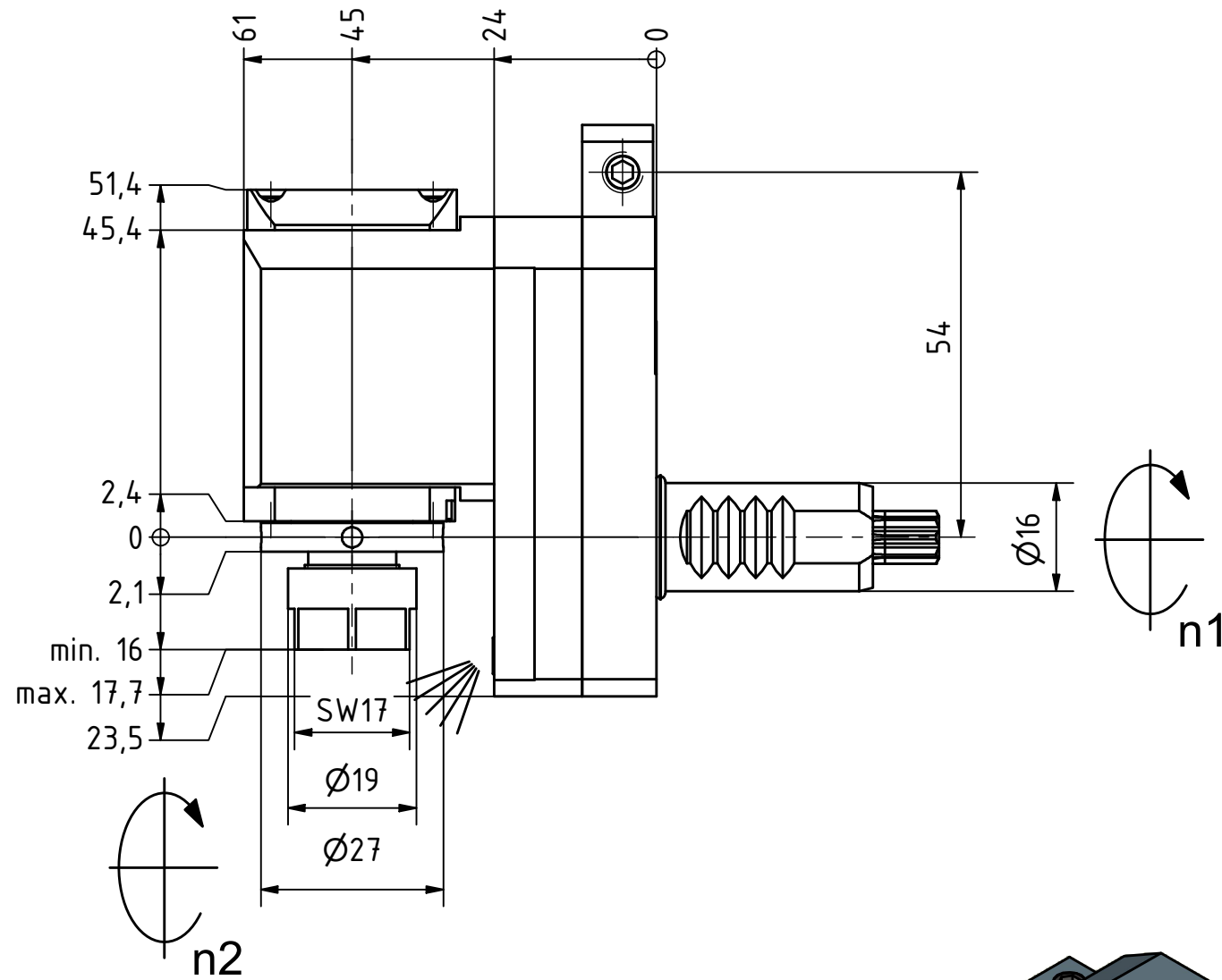

Tech
Details



Spannzange / Collet ER11 DIN6499
Spannbereich / Clamping range: 0,5 - 7,0

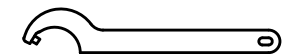
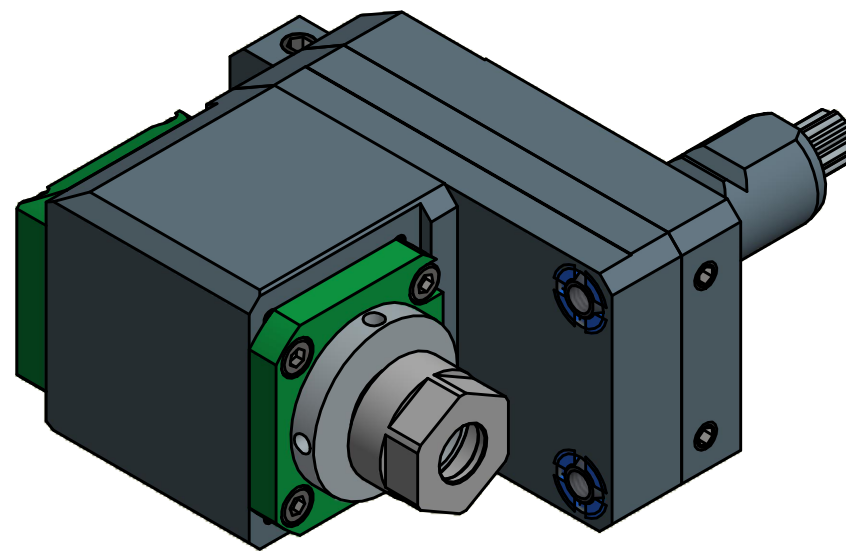

Hakenschlüssel
mit Zapfen
Hook wrench
with fixed pin
DIN1810 B 25x28

Copyright **EWS Tool Technologies**
Weitergabe und Vervielfältigung dieser Unterlage,
Verwertung und Mitteilung ihres Inhalts nicht
gestattet, soweit nicht ausdrücklich zugestanden.
Zuwendungen verpflichten zu Schadenersatz.

Bemerkung - Note

Technische Daten - technical data

Weight = 1.080 [kg]
Torque max. (M1/M2) = 6,3 / 3,15 [Nm]
Speed max. (n1/n2) = 8000 / 16000 [1/min]
Gear ratio (i)=n1:n2 = 1:2

Benennung - Title

Radial Bohr und Fräskopf, zurückges
Radial drill. and mill. head offset



EWS Weigle GmbH & Co. KG
Maybachstr. 1
D-73066 Uhingen
www.ews-tools.de

Technische Änderungen vorbehalten!
Subject to technical modifications!

IDENT: DEWS138207



REV: -/A

Nr. - No.

80.16125480W8R11

MNR.

224484

