

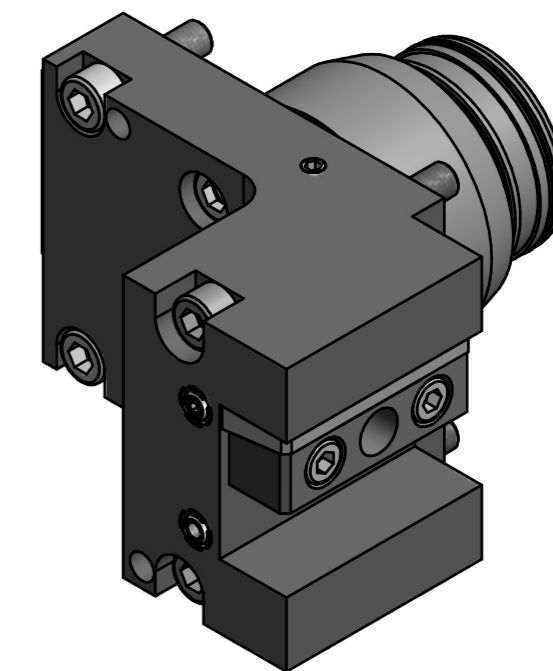

Kühlmittelbohrung
Coolant drilling

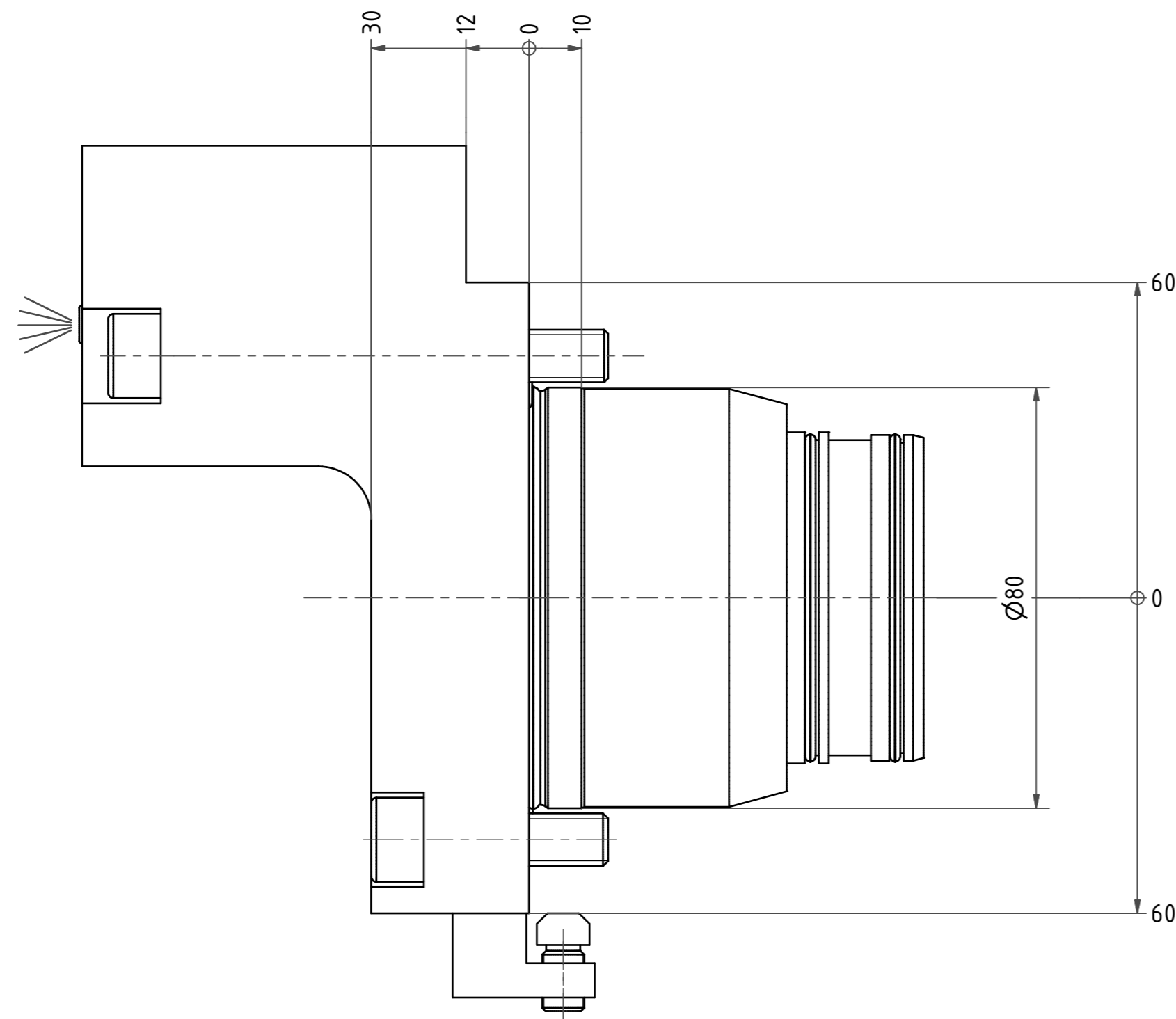
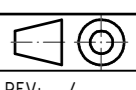

Copyright **EWS Tool Technologies**
Weitergabe und Vervielfältigung dieser Unterlage,
Verwertung und Mitteilung ihres Inhalts nicht
gestattet, soweit nicht ausdrücklich zugestanden.
Zuwendungen verpflichten zu Schadenersatz.

Bemerkung - Note	Technische Daten - technical data Weight = 7.133 [kg]	Benennung - Title Vierkant Längsaufnahme rechts <i>turning holder, right hand</i>	 EWS Weigle GmbH & Co. KG Maybachstr. 1 D-73066 Ulmringen www.ews-tools.de	Technische Änderungen vorbehalten! Subject to technical modifications! IDENT: D-EWS-176060 Nr. - No. MNR. 1.CDI80S25	 REV: -/- 182265
------------------	---	--	---	---	---