

Alternativ werden Zylinderschrauben mit Innensechskant mitgeliefert.
Hexagon socket head cap screws are also delivered.

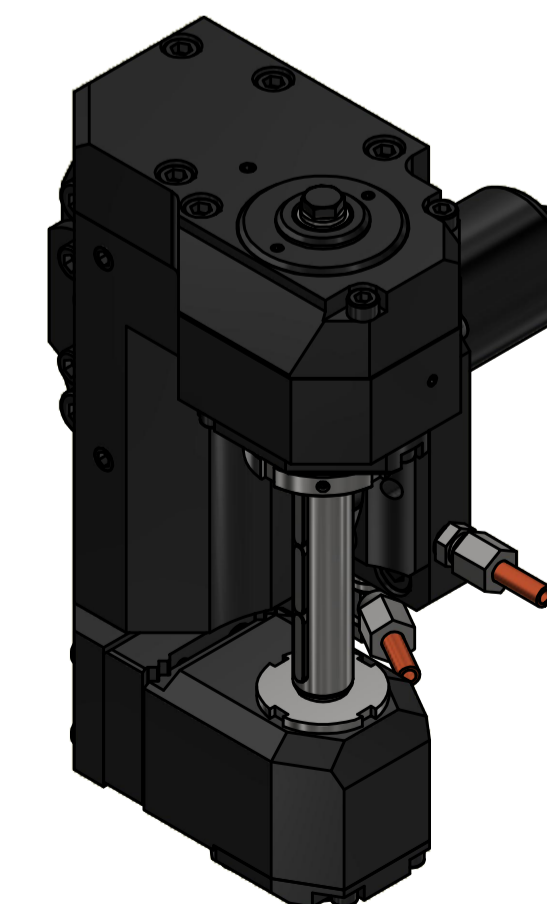
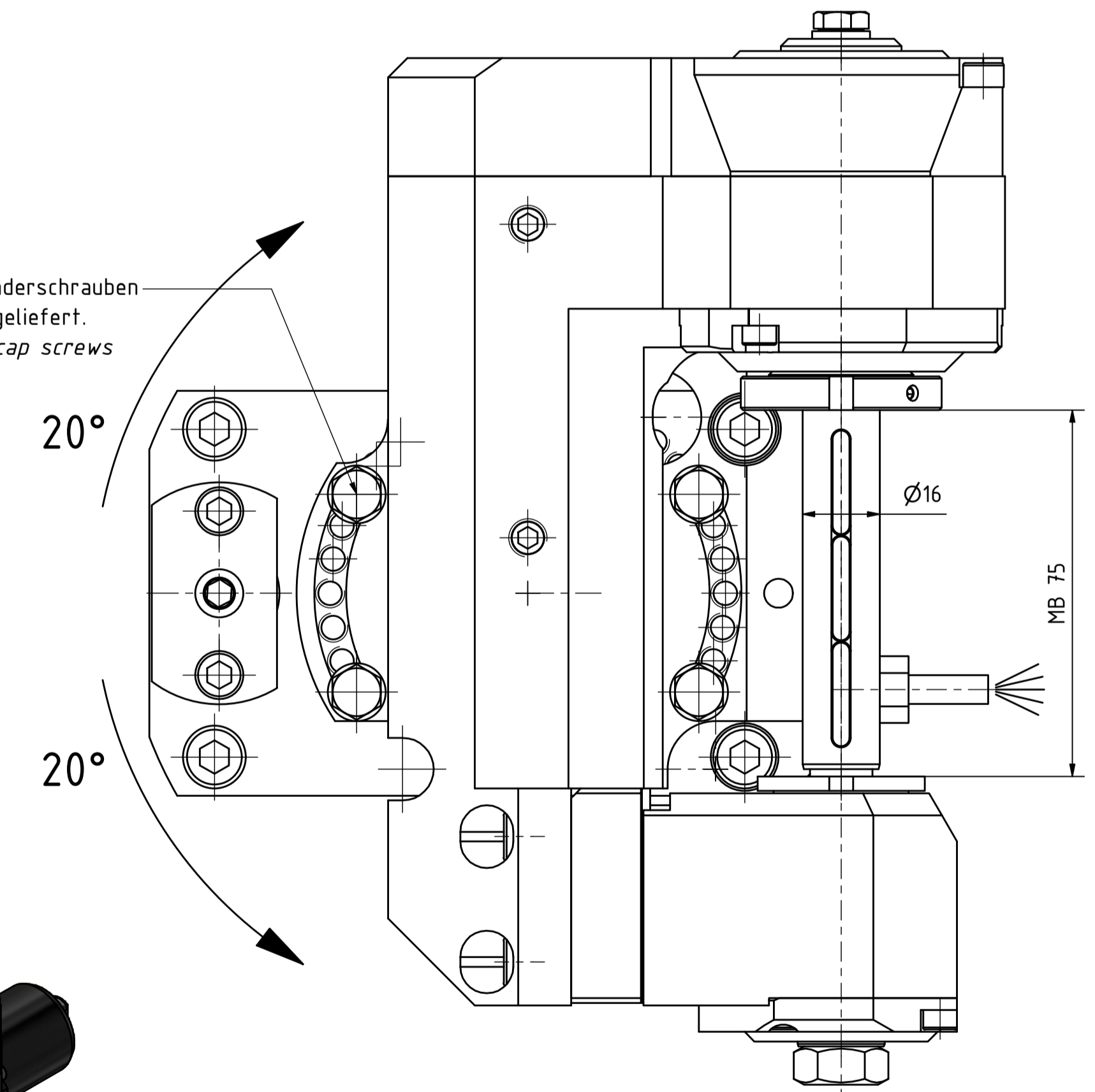

Gewicht: 10,7 kg
Weight: 10,7 kg

Beide Nachbarstationen nicht verwendbar!
Both neighbour stations are not useable!

Bemerkung - Note
mit Kegelrollenlagern
with taper roller bearings

Technische Daten - technical data
Weight = 10.256 [kg]
Torque max. (M1/M2) = 4.0 / 80 [Nm]
Speed max. (n1/n2) = 6000 / 3000 [1/min]
Gear ratio (i)=n1:n2 = 2:1

Bezeichnung - Title
Scheibenfräserkopf
Radial saw milling head

EWS Tool Technologies	EWS Werkzeug GmbH & Co. KG Hauptstr. 1 D-72076 Ulm www.ews-tool.de	Technische Änderungen vorbehalten! Subject to technical modifications!	REV. - / A	QR
		IDENT: DEWS231459		
64.6816QSMBMTI2TKWZ65MB75			221465	

Copyright EWS Tool Technologies
Weitergabe und Vervielfältigung dieser Unterlage,
Verwertung und Mitteilung ihres Inhalts nicht
gestattet, soweit nicht ausdrücklich zugestanden.
Zu widerhandlungen verpflichten zu Schadenersatz.