

max. Fraeserdurchmesser Ø80
max. saw milling diameter

Markierung Fräserstellung
Cutter position mark

Fraeserwelle austauschbar
spindle removable

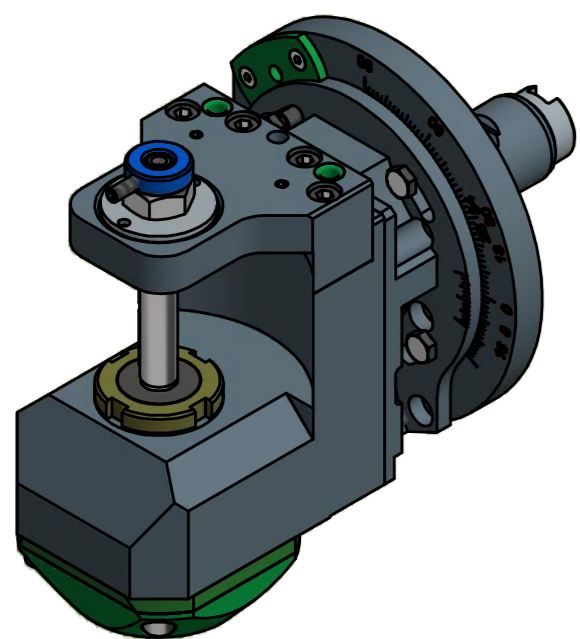
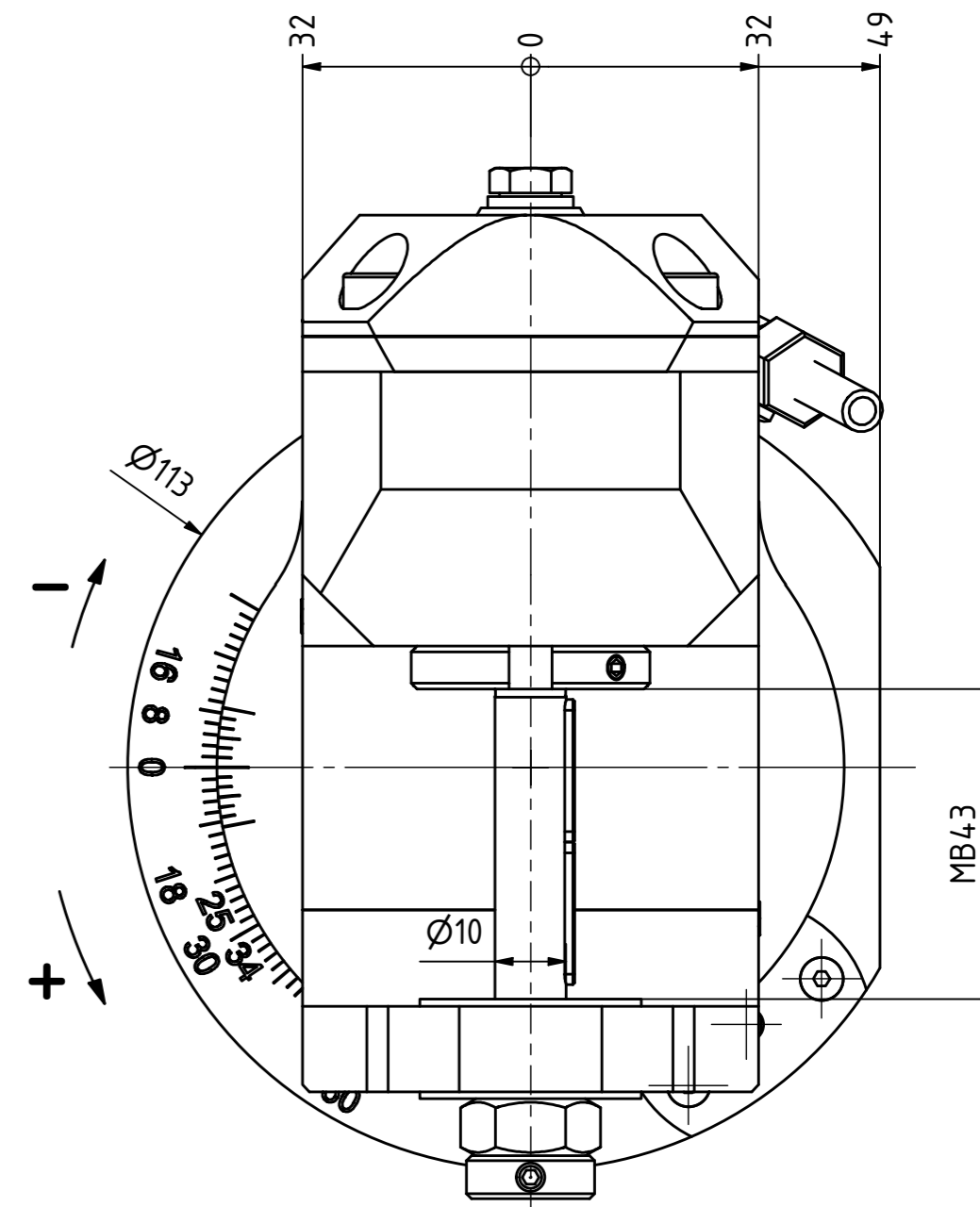
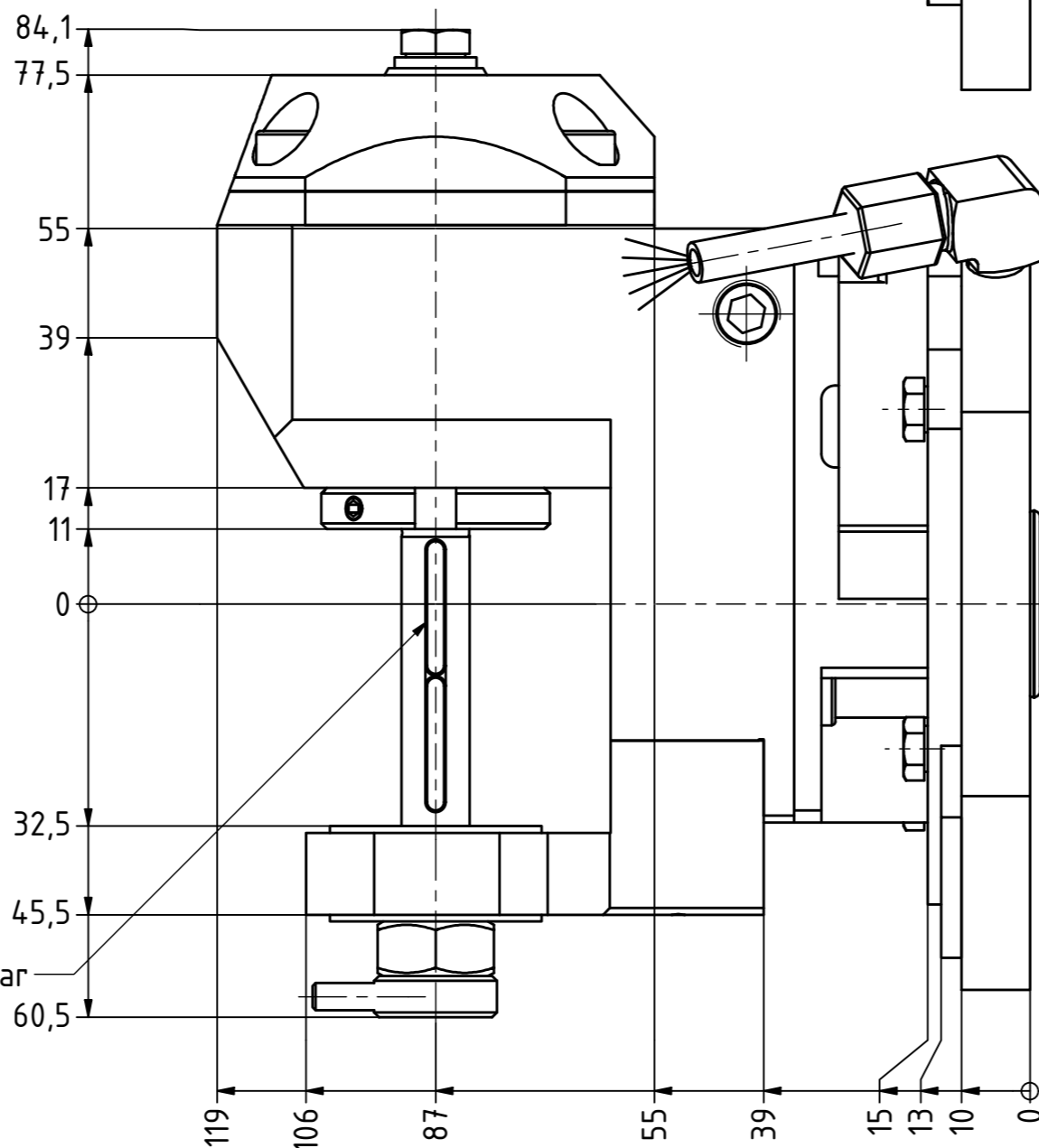
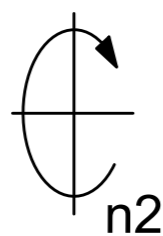
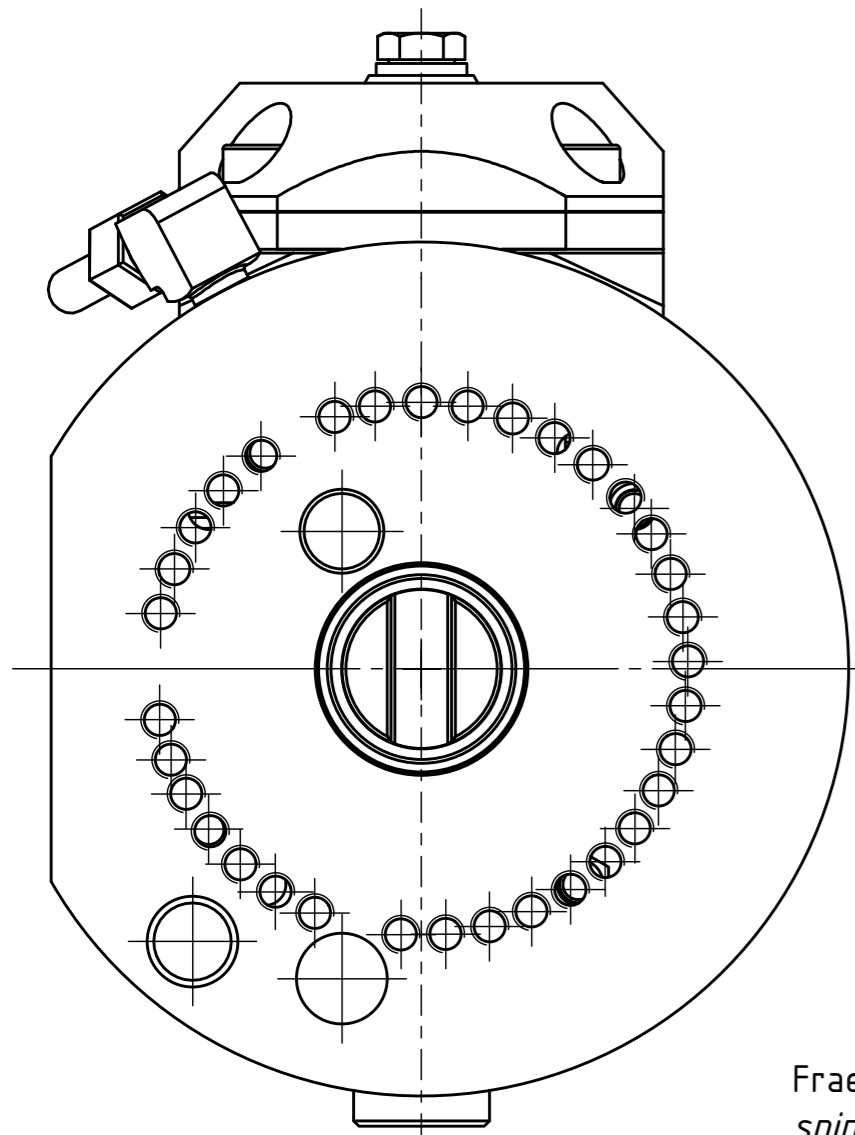

Maschine mit Y oder YB-Achse Rev. 1: -16° bis +34°
 Maschine ohne Y-Achse Rev. 1: -16° bis +25°
 Einsatz auf Rev. 2 ist nicht möglich.
 Beide Nachbarstationen nicht verwendbar!
 Machine with Y or YB-axis Rev. 1: -16° to +34°
 Machine without Y-axis Rev. 1: -16° to +25°
 Employment on Rev. 2 is not possible.
 both neighboring are not useable!

Copyright EWS Tool Technologies
 Weitergabe und Vervielfältigung dieser Unterlage,
 Verwertung und Mitteilung ihres Inhalts nicht
 gestattet, soweit nicht ausdrücklich zugestanden.
 Zuwiderhandlungen verpflichten zu Schadenersatz.

Bemerkung - Note 	Technische Daten - technical data Weight = 4,574 [kg] Torque max. (M1/M2) = 20 / 60 [Nm] Speed max. (n1/n2) = 6000 / 2000 [1/min] Gear ratio (i)=n1:n2 = 3:1	Benennung - Title Scheibenfräserkopf <i>Radial saw milling head</i>	<table border="0"> <tr> <td data-bbox="2240 1917 2463 1984"> EWS <small>EWS Weigle GmbH & Co. KG Maybachstr. 1 D-73066 Ulm/Ingen www.ews-tools.de</small> </td> <td data-bbox="2463 1917 2686 1984"> Technische Änderungen vorbehalten! Subject to technical modifications! IDENT: DEWS040041 </td> <td data-bbox="2686 1917 2789 1984"> REV: -/C </td> <td data-bbox="2789 1917 2908 1984"> </td> </tr> <tr> <td data-bbox="2240 1984 2463 2047"> Nr. - No. 64.2510G20013TKWMB43-S01 </td> <td data-bbox="2463 1984 2686 2047"> MNR. 206892 </td> <td colspan="2" data-bbox="2686 1984 2908 2047"> QR </td> </tr> </table>	EWS <small>EWS Weigle GmbH & Co. KG Maybachstr. 1 D-73066 Ulm/Ingen www.ews-tools.de</small>	Technische Änderungen vorbehalten! Subject to technical modifications! IDENT: DEWS040041	 REV: -/C		Nr. - No. 64.2510G20013TKWMB43-S01	MNR. 206892	QR	
EWS <small>EWS Weigle GmbH & Co. KG Maybachstr. 1 D-73066 Ulm/Ingen www.ews-tools.de</small>	Technische Änderungen vorbehalten! Subject to technical modifications! IDENT: DEWS040041	 REV: -/C									
Nr. - No. 64.2510G20013TKWMB43-S01	MNR. 206892	QR									