

Doppelverzahnung Lizenz Traub
double tooth system licence Traub

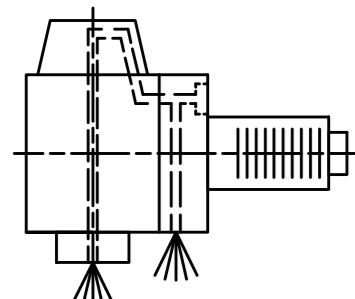
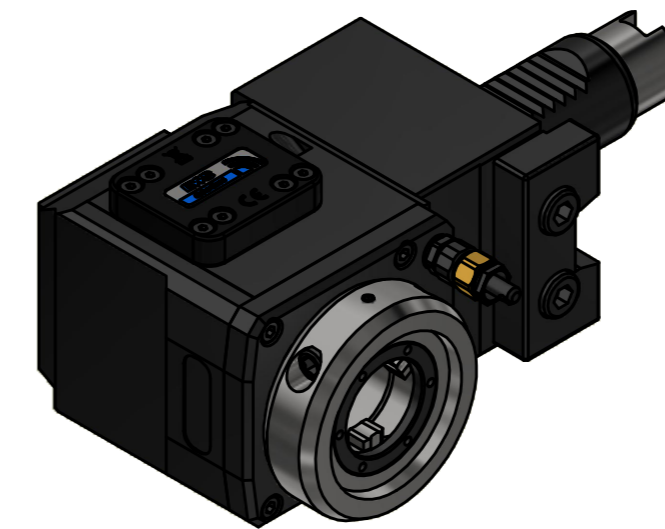

Innen- und Aussenkuehlung / Inside and outside coolant supply
Kuehlmittefiltration-50 μ / coolant filtration-50 μ

Copyright **EWS Tool Technologies**
Weitergabe und Vervielfaeltigung dieser Unterlage,
Verwertung und Mitteilung ihres Inhalts nicht
gestattet, soweit nicht ausdrecklich zugestanden.
Zuwiderhandlungen verpflichten zu Schadenersatz.

Bemerkung - Note Für Trockenlauf geeignet! Use without coolant fluid allowed!	Technische Daten - technical data Weight = 4,886 [kg]
	Torque max. (M1/M2) = 32 / 32 [Nm]
	Speed max. (n1/n2) = 8000 / 8000 [1/min]
	Gear ratio (i)=n1:n2 = 1:1
	Pressure (pmax) = 70 [bar]

Benennung - Title
Radial Bohr und Fräskopf
Radial drilling and milling head

EWS Tool Technologies <small>EWS Weigle GmbH & Co. KG Maybachstr. 1 D-73066 Uhlingen www.ews-tools.de</small>	Technische Aenderungen vorbehalten! Subject to technical modifications! IDENT: DEWS259622	REV: -/A MNR.
	Nr. - No. 60.30VX3G300RLIKDV-CC4	219815

