

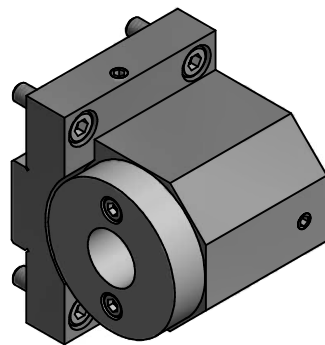

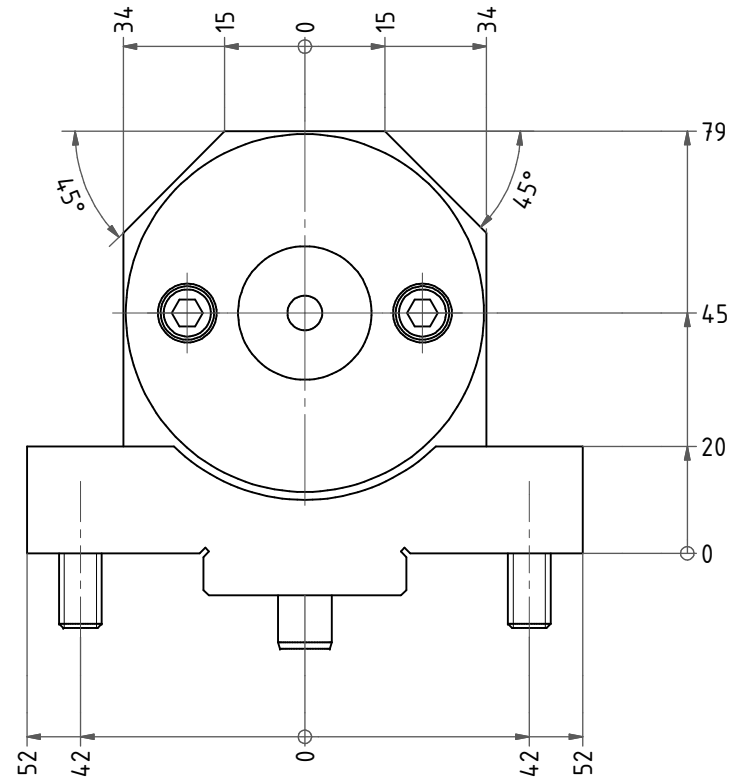

Hydrodehnfutter / hydraulic chuck NBC-25/32-50

Hülsen / collets 28.25xxHYDSP

XX (Ø)	3	4	5	6	7	8	9	10	12	14	16	18	20
	1/8	3/16	1/4	5/16	3/8	7/16	1/2	9/16	5/8				



Copyright **EWS Tool Technologies**
 Weitergabe und Vervielfältigung dieser Unterlage,
 Verwertung und Mitteilung ihres Inhalts nicht
 gestattet, soweit nicht ausdrücklich zugestanden.
 Zuwiderhandlungen verpflichten zu Schadenersatz.

Bemerkung - Note	Technische Daten - technical data Weight = 3.363 [kg]	Benennung - Title Bohrstangenhalter boring bar holder	 EWS Weigelt GmbH & Co. KG Maybachstr. 1 D-73066 Uhingen www.ews-tools.de	Technische Änderungen vorbehalten! Subject to technical modifications!	 REV: -/A MNR.	
				IDENT: DEWS003030		