

Winkelausrichtung & CD-ROM  
in Lieferung enthalten!  
Angle adjusting & CD-ROM  
included in delievery!

max. Fraeserdurchmesser  $\varnothing 80$   
max. saw millingdiameter

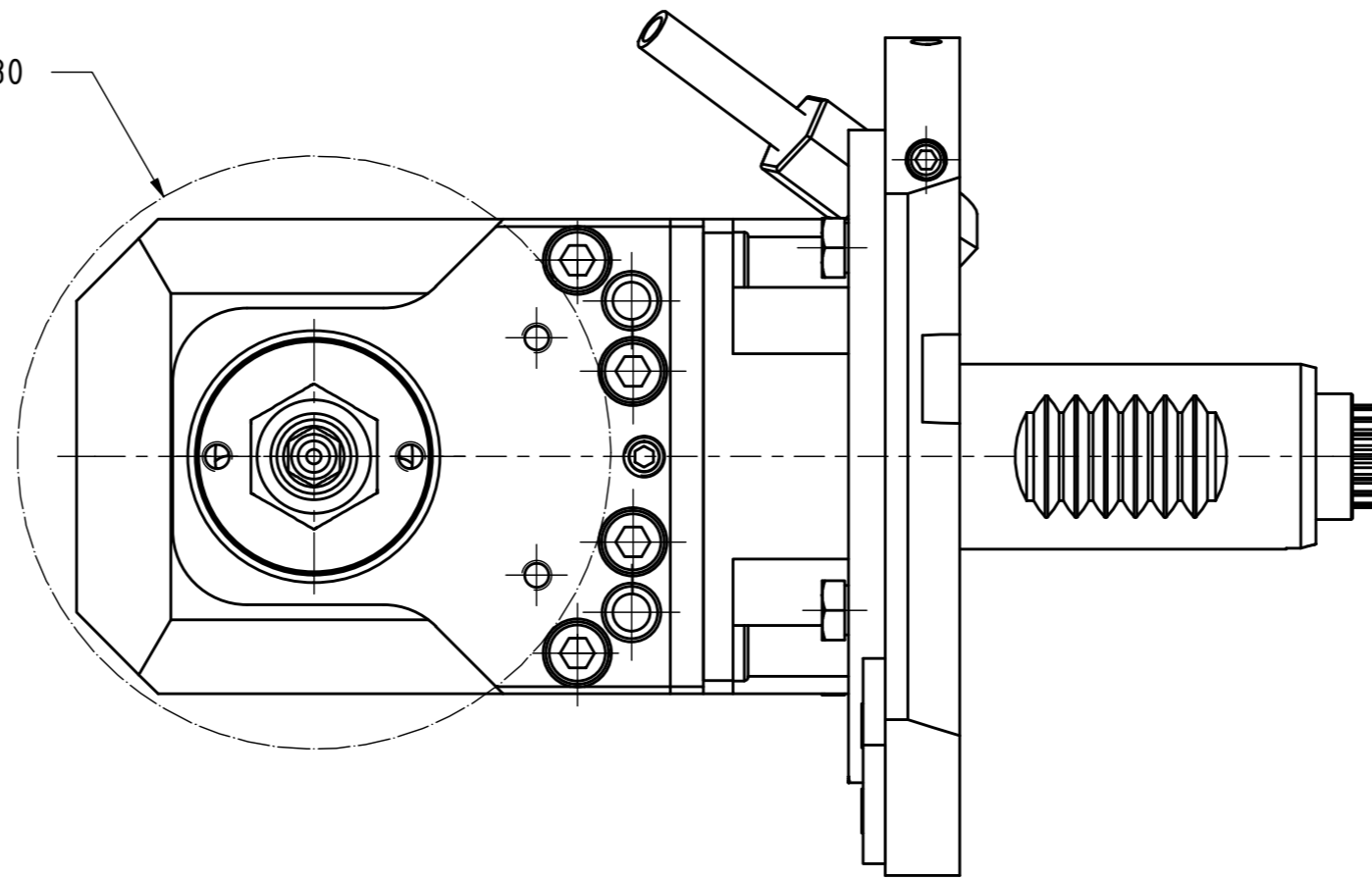

min. und max. Schwenkwinkel beziehen sich auf den Werkzeughalter.  
Zusätzlich muss eine Kollisionsbetrachtung im Arbeitsraum durchgeführt werden!  
min. and max. swiveling angle refer to the tool  
in addition the work space of the machine has to be checked for interferences!

Beide Nachbarstationen nicht verwendbar!  
both neighboring are not useable!

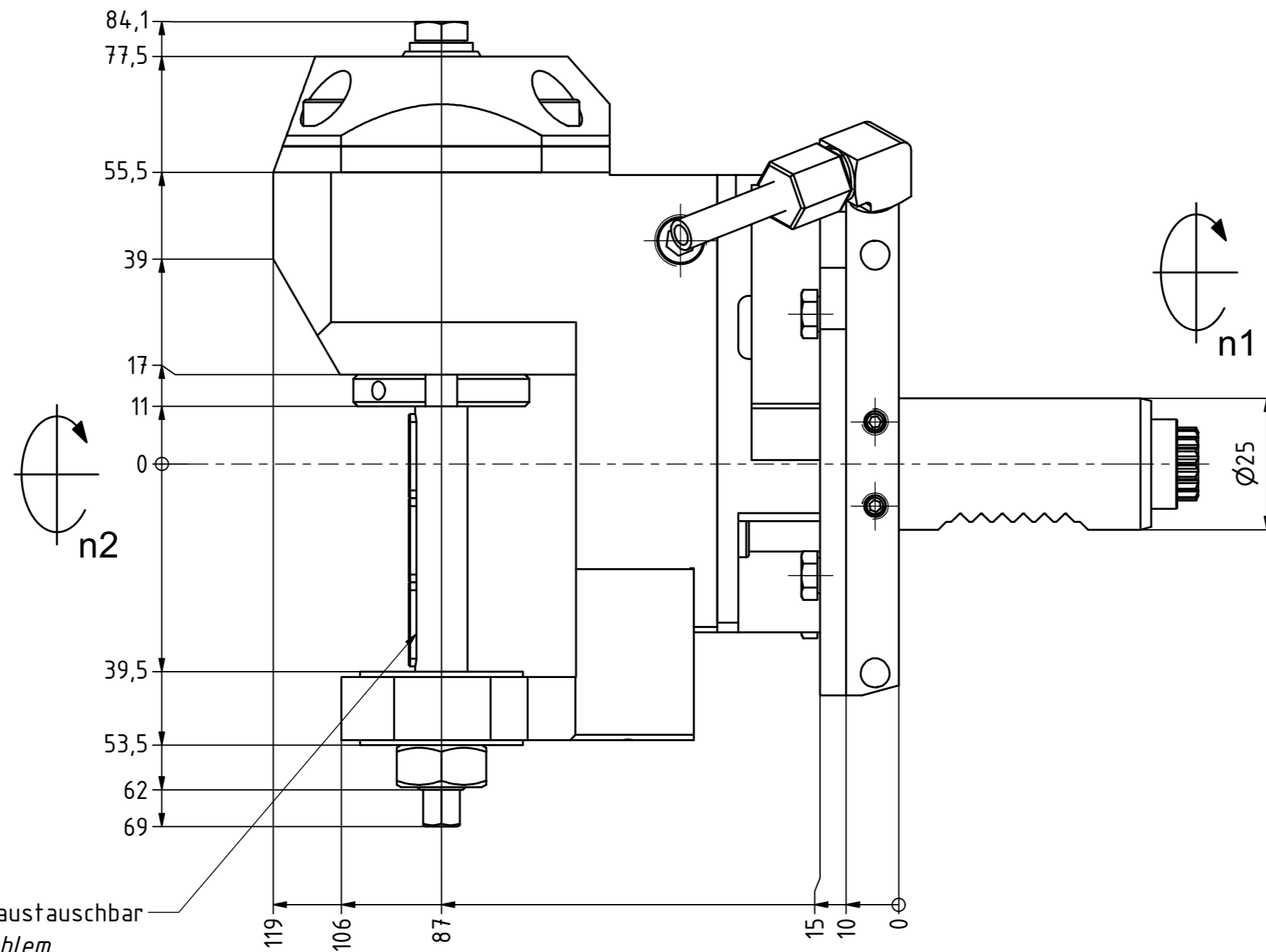
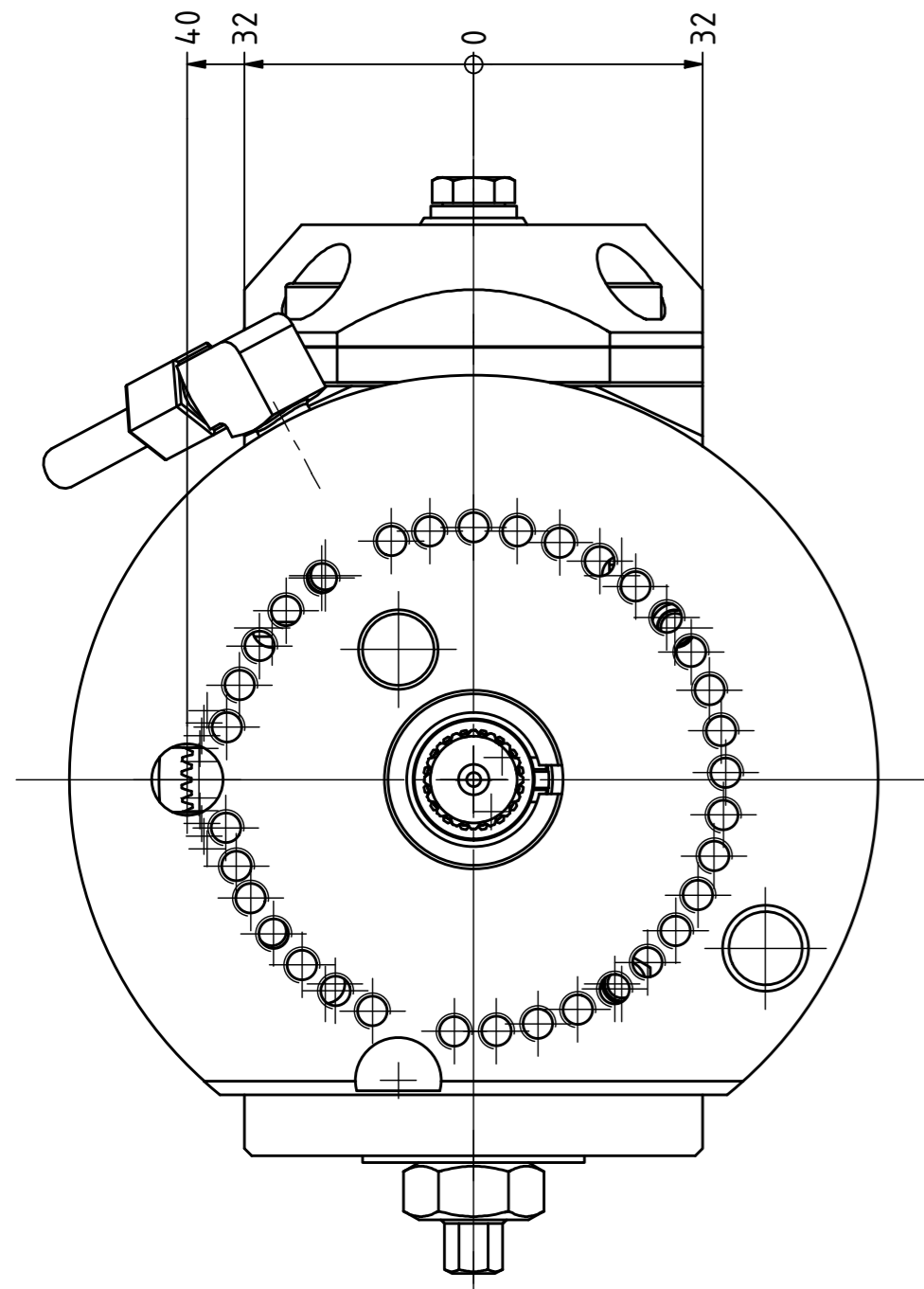

Fraeserwelle austauschbar  
Spindle reovable

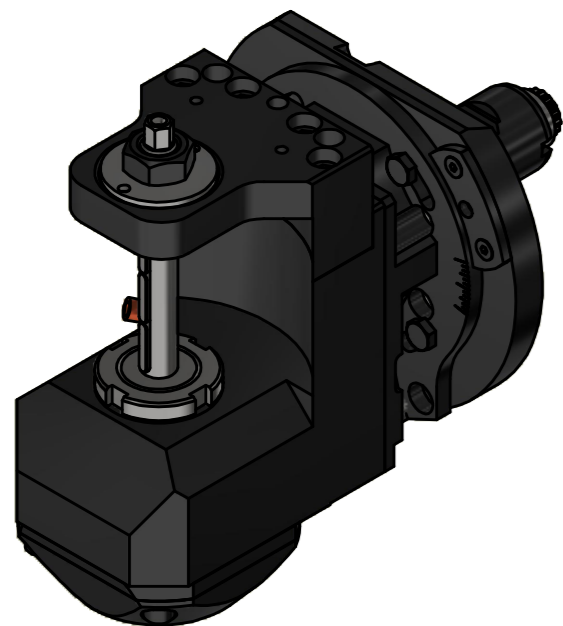
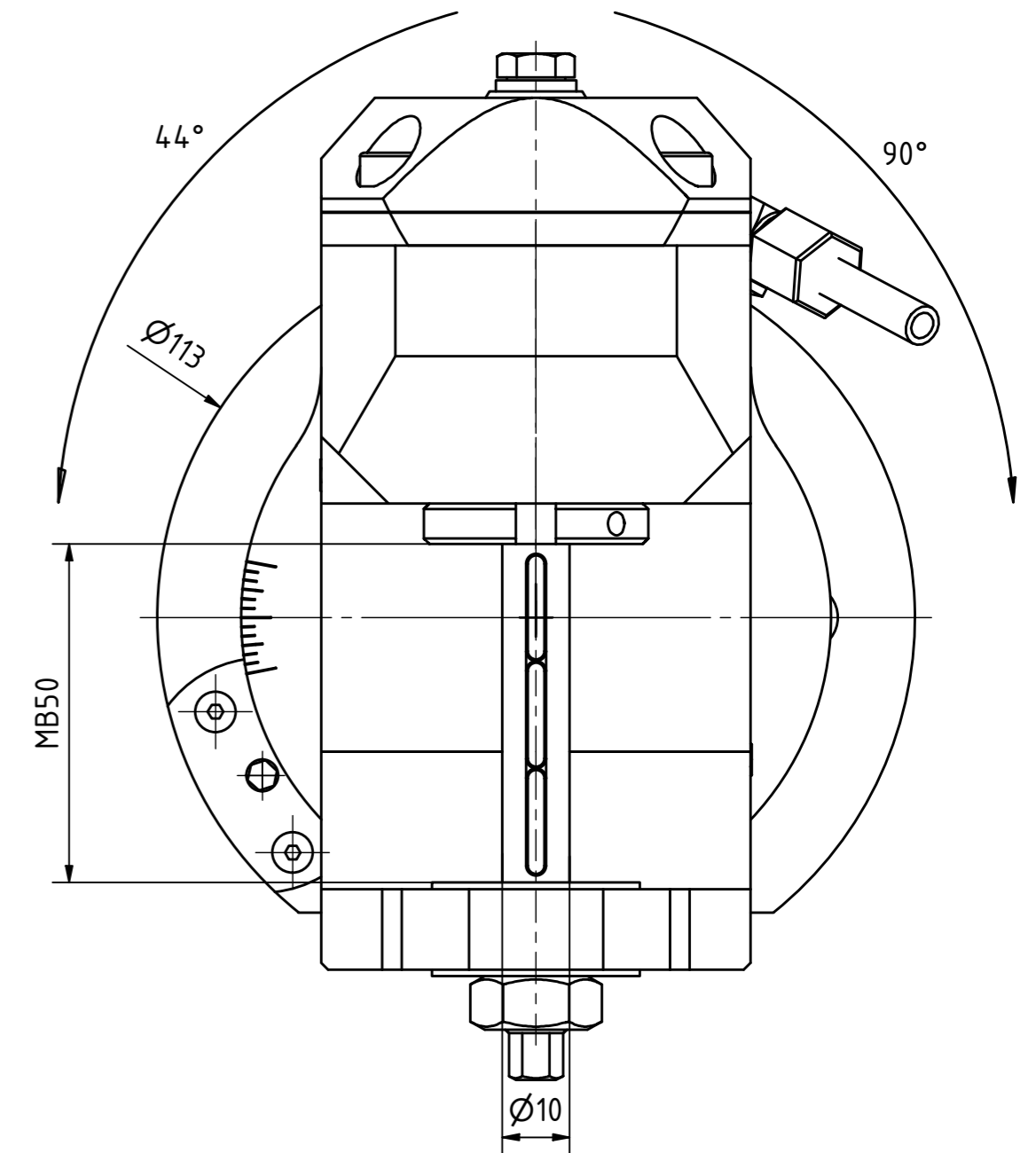

Copyright **EWS Tool Technologies**  
Weitergabe und Vervielfältigung dieser Unterlage,  
Verwertung und Mitteilung ihres Inhalts nicht  
gestattet, soweit nicht ausdrücklich zugestanden.  
Zuwerhandlungen verpflichten zu Schadenersatz.

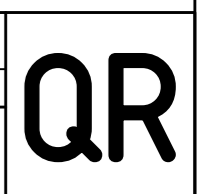
Bemerkung - Note 	Technische Daten - technical data <b>Weight</b> = 4,285 [kg] <b>Torque max.</b> (M1/M2) = 20 / 60 [Nm] <b>Speed max.</b> (n1/n2) = 6000 / 2000 [1/min] <b>Gear ratio</b> (i)=n1:n2 = 3:1	Benennung - Title <b>Scheibenfräserkopf</b> <b>Radial saw milling head</b>	 <b>EWS</b> Weigle GmbH & Co. KG Maybachstr. 1 D-73066 Uhlingen www.ews-tools.de	Technische Änderungen vorbehalten! Subject to technical modifications! IDENT: DEWS150176 Nr. - No. <b>64.2510548013TKWMB50</b>	MNR. <b>140391</b>	
----------------------	--	--	--	--	-----------------------	---