

max. Fraeserdurchmesser Ø80
max. saw milling diameter

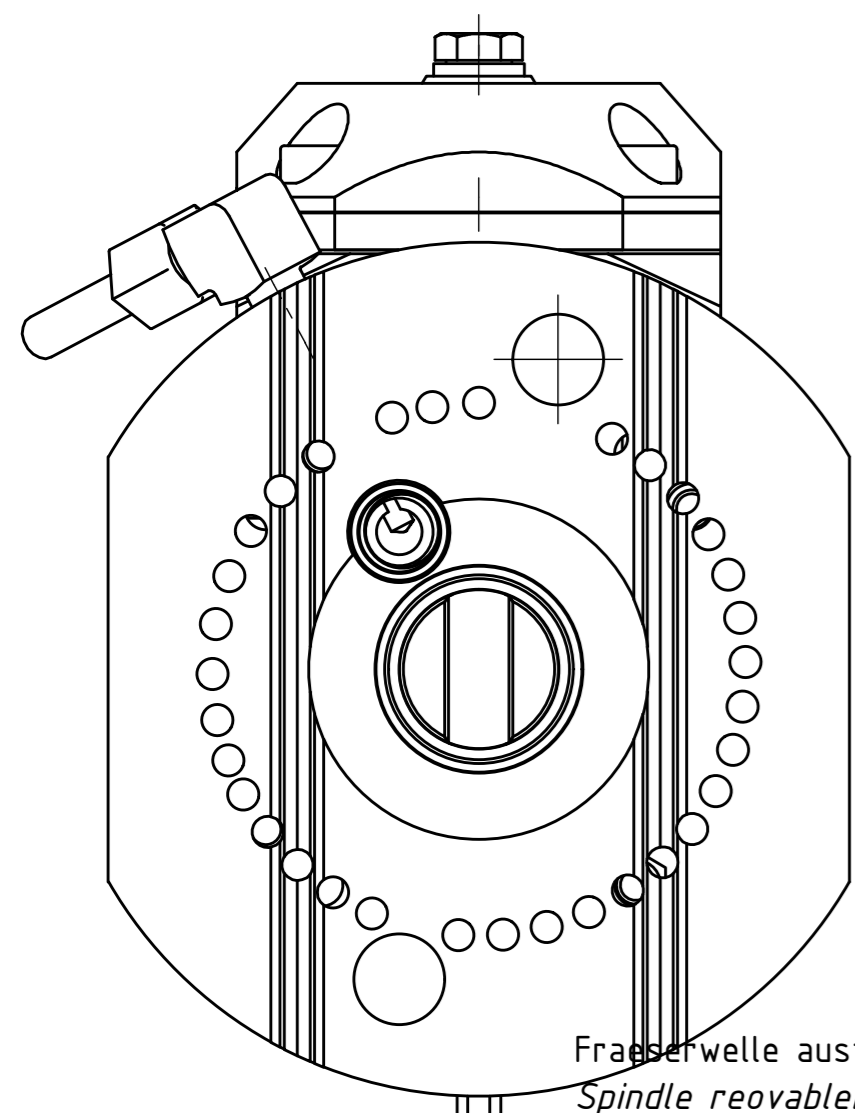

Fraeserwelle austauschbar
Spindle reovable

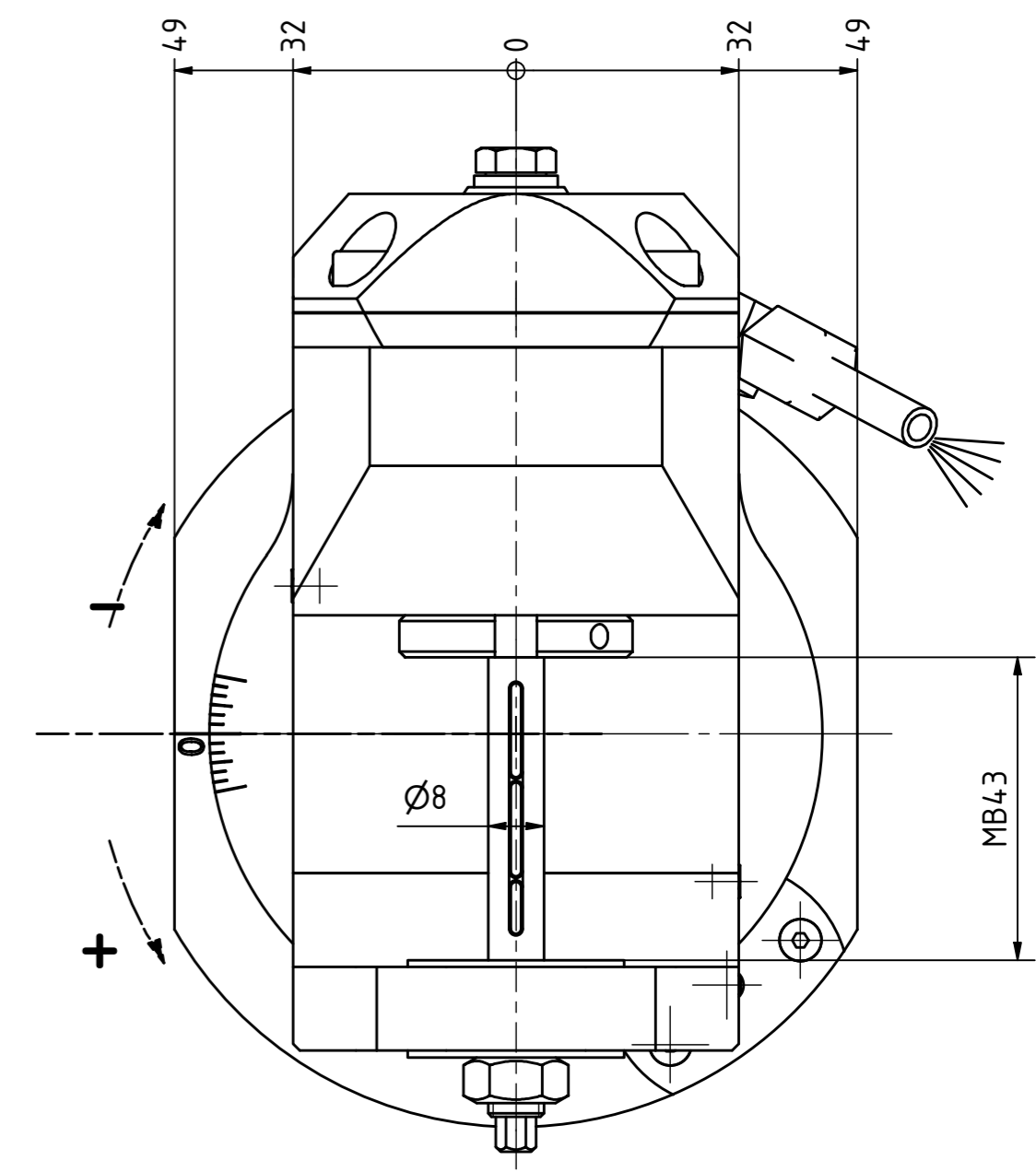
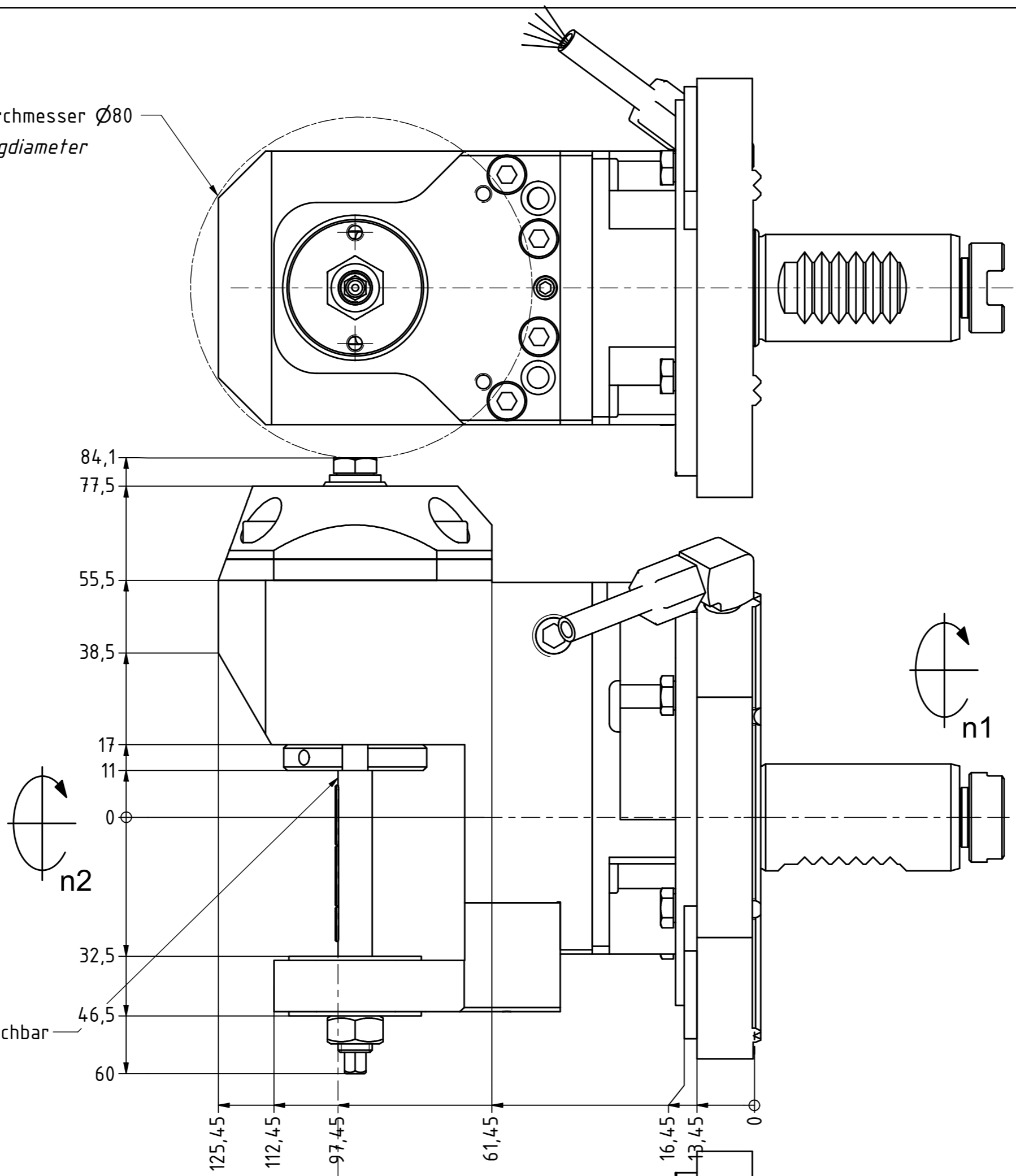

W-Verzahnung Lizenz Index-Werke
W-tooth system licence Index-Corporation

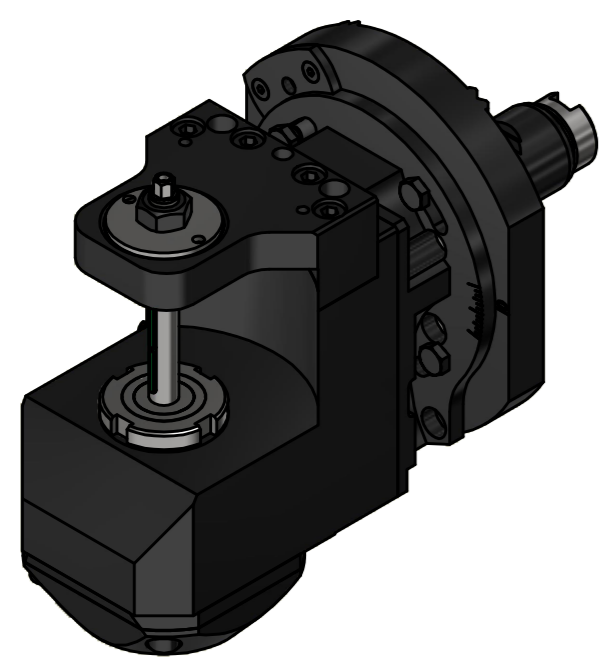

Maschine mit Y oder YB-Achse Rev. 1: -16° bis +10°
 Maschine ohne Y-Achse Rev. 1: -8° bis +10°
 Einsatz auf Rev. 2 ist nicht möglich.
 Beide Nachbarstationen nicht verwendbar!
 Machine with Y or YB-axis Rev. 1: -16° to +10°
 Machine without Y-axis Rev. 1: -8° to +10°
 Employment on Rev. 2 is not possible.
 both neighboring are not useable!

Copyright EWS Tool Technologies
 Weitergabe und Vervielfältigung dieser Unterlage,
 Verwertung und Mitteilung ihres Inhalts nicht
 gestattet, soweit nicht ausdrücklich zugestanden.
 Zuwiderhandlungen verpflichten zu Schadenersatz.

Bemerkung - Note 	Technische Daten - Technical data Weight = 4,996 [kg] Torque max. (M1/M2) = 20 / 20 [Nm] Speed max. (n1/n2) = 6000 / 6000 [1/min] Gear ratio (i)=n1:n2 = 1:1	Benennung - Title Scheibenfräserkopf Radial saw milling head	<table border="1"> <tr> <td data-bbox="2226 1911 2463 1984"> EWS <small>EWS Weigle GmbH & Co. KG Maybachstr. 1 D-73066 Uhingen www.ews-tool.de</small> </td> <td data-bbox="2463 1911 2700 1984"> Technische Änderungen vorbehalten! Subject to technical modifications! IDENT: D-EWS-203143 </td> <td data-bbox="2700 1911 2923 1984"> REV: -/A MNR. </td> </tr> <tr> <td data-bbox="2226 1984 2463 2047"> Nr. - No. 64.2508G200WTKWMB43 </td> <td data-bbox="2463 1984 2700 2047"> 192675 </td> <td data-bbox="2700 1984 2923 2047"> QR </td> </tr> </table>	EWS <small>EWS Weigle GmbH & Co. KG Maybachstr. 1 D-73066 Uhingen www.ews-tool.de</small>	Technische Änderungen vorbehalten! Subject to technical modifications! IDENT: D-EWS-203143	 REV: -/A MNR.	Nr. - No. 64.2508G200WTKWMB43	192675	QR
EWS <small>EWS Weigle GmbH & Co. KG Maybachstr. 1 D-73066 Uhingen www.ews-tool.de</small>	Technische Änderungen vorbehalten! Subject to technical modifications! IDENT: D-EWS-203143	 REV: -/A MNR.							
Nr. - No. 64.2508G200WTKWMB43	192675	QR							