

Ø16 Exzenter
Ø16 excentric

Fraeserwelle austauschbar
Spindle removable

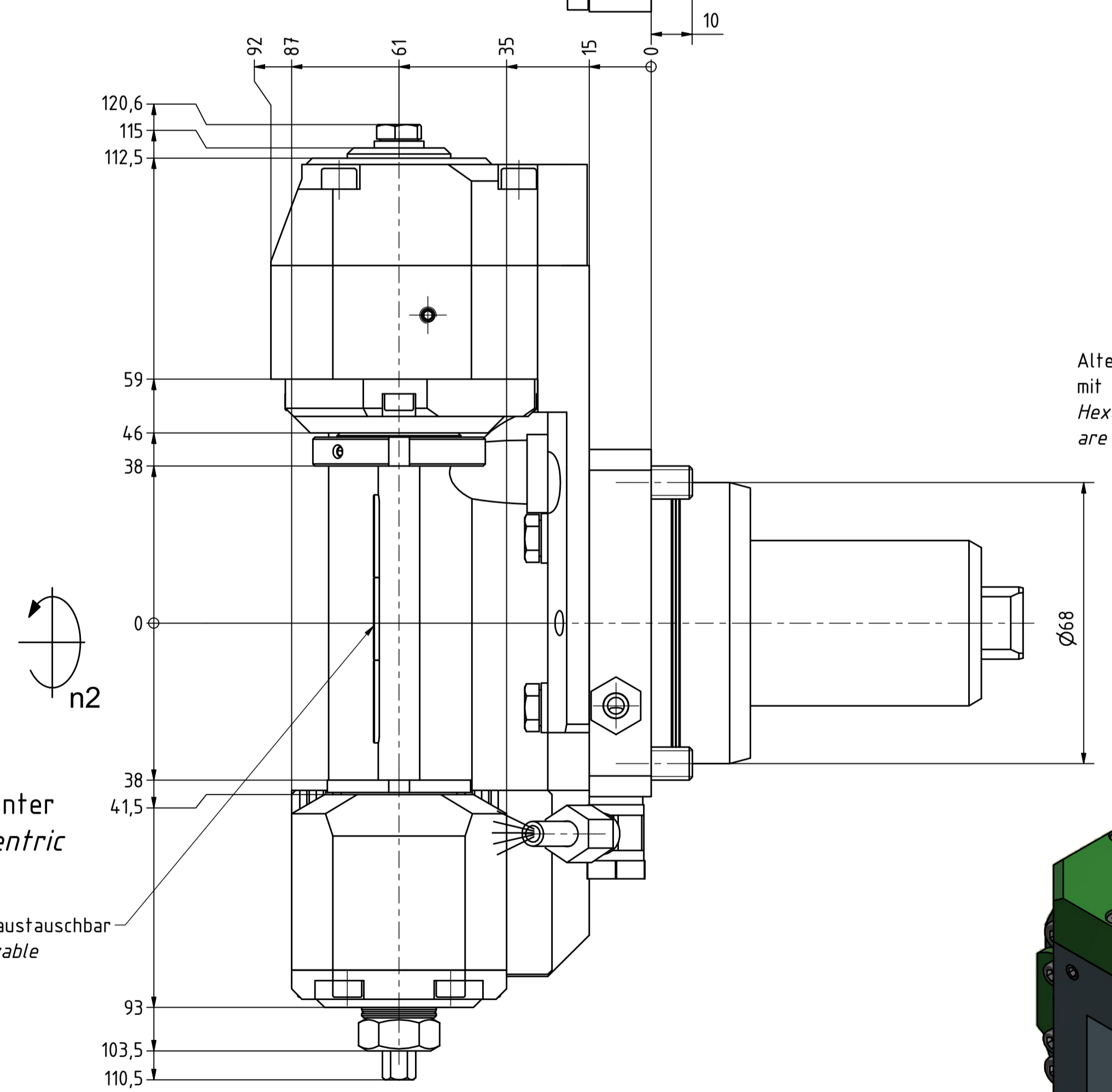

Alternativ werden Zylinderschrauben
mit Innensechskant mitgeliefert.
Hexagon socket head cap screws
are also delivered.

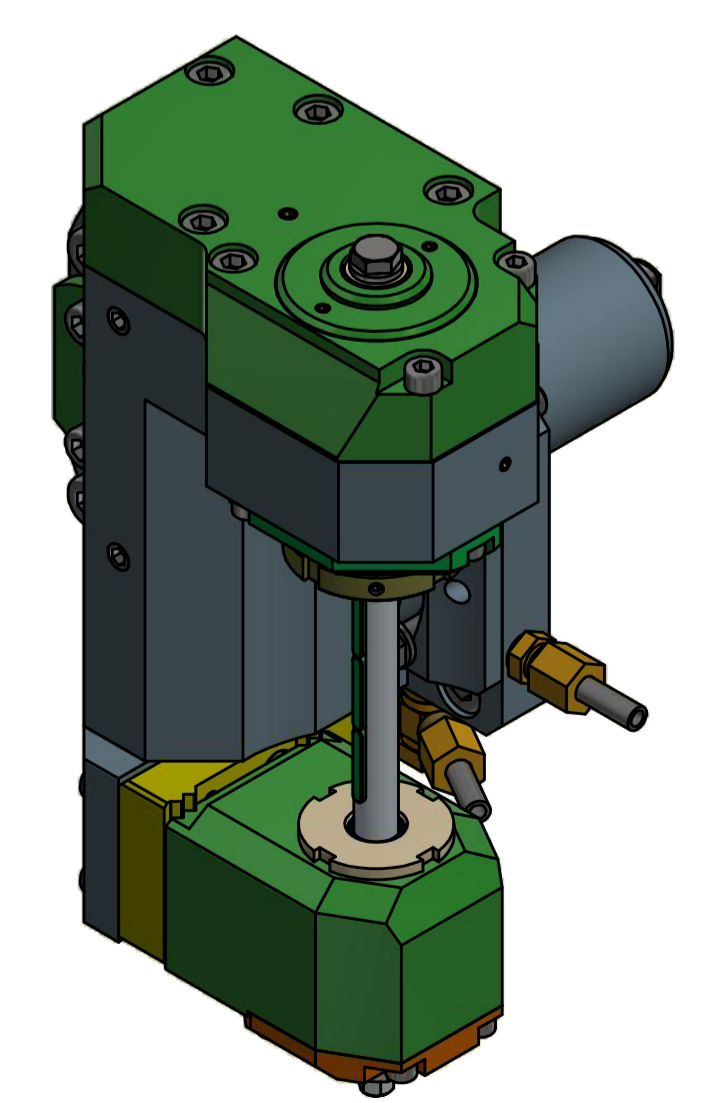
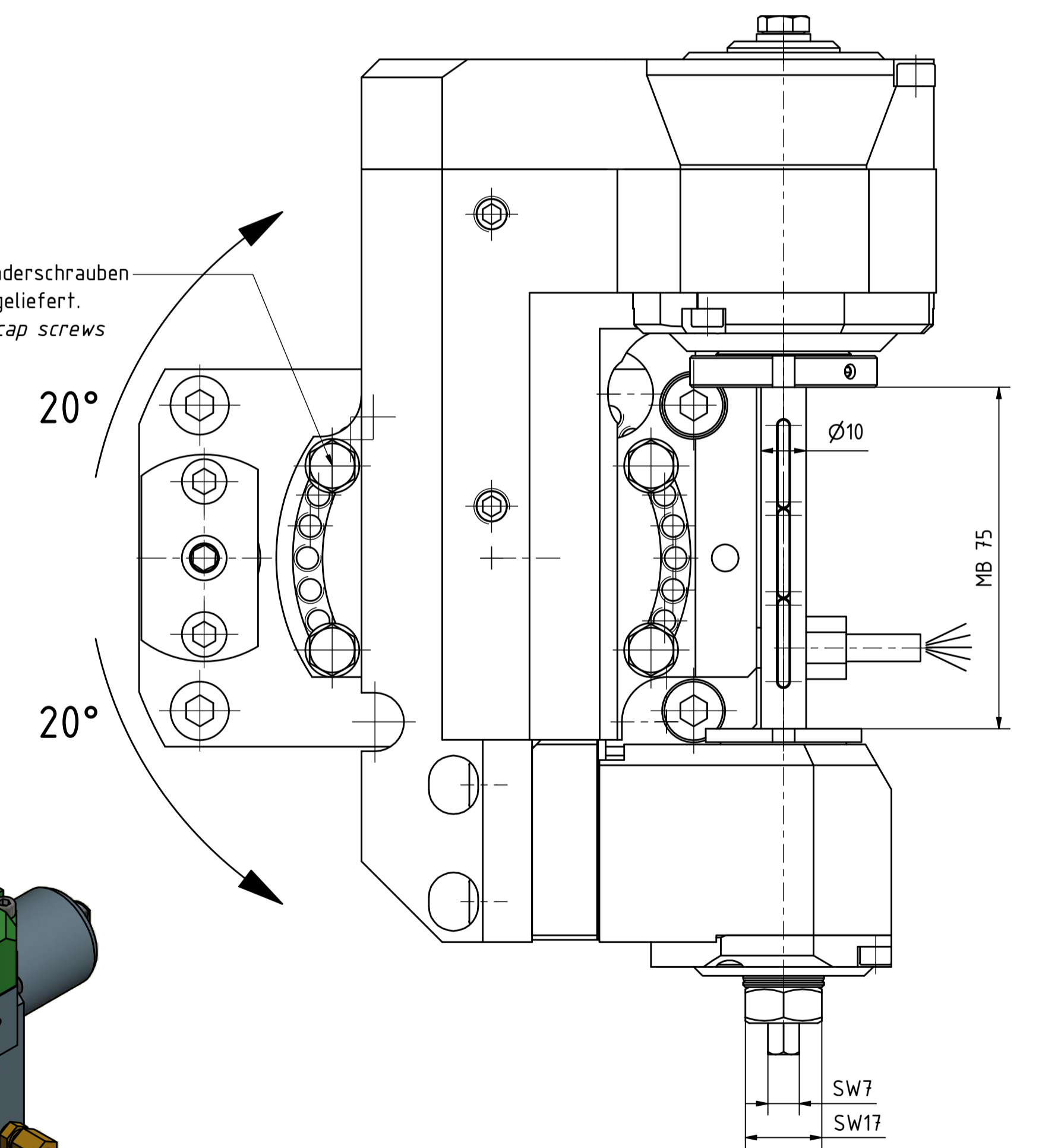

Beide Nachbarstationen nicht verwendbar!
Both neighbour stations are not useable!

<p>Benennung - Note</p> <p>mit Kegelrollenlager with taper roller bearing(s)</p>	<p>Technische Daten - Technical data</p> <p>Weight = 10,189 [kg] Torque max. (M1/M2) = 4,0 / 80 [Nm] Speed max. (n1/n2) = 6000 / 3000 [1/min] Gear ratio (i)=n1:n2 = 2:1</p>	<p>Benennung - Title</p>	<p>EWS Werkzeug GmbH & Co. KG Hauptstr. 1 D-72084 Stuttgart www.ews-tool.de</p> <p>Technische Änderungen vorbehalten! Subject to technical modifications!</p> <p>IDENT: DEWS037609</p> <p>REV. -/JC</p> <p>NR. - 00</p> <p>64.6810QSMBMTI2TKWZ65MB75</p>	<p>199903</p> <p>QR</p>
--	--	--------------------------	--	-------------------------

Copyright EWS Tool Technologies
Weitergabe und Vervielfältigung dieser Unterlage,
Verwertung und Mitteilung ihres Inhalts nicht
gestattet, soweit nicht ausdrücklich zugestanden.
Zu widerhandlungen verpflichten zu Schadenersatz.