

Winkelausrichtung & CD-ROM
in Lieferung enthalten!
Angle adjusting & CD-ROM
included in delivery!

max. Fraeserdurchmesser $\varnothing 80$
max. saw milling diameter

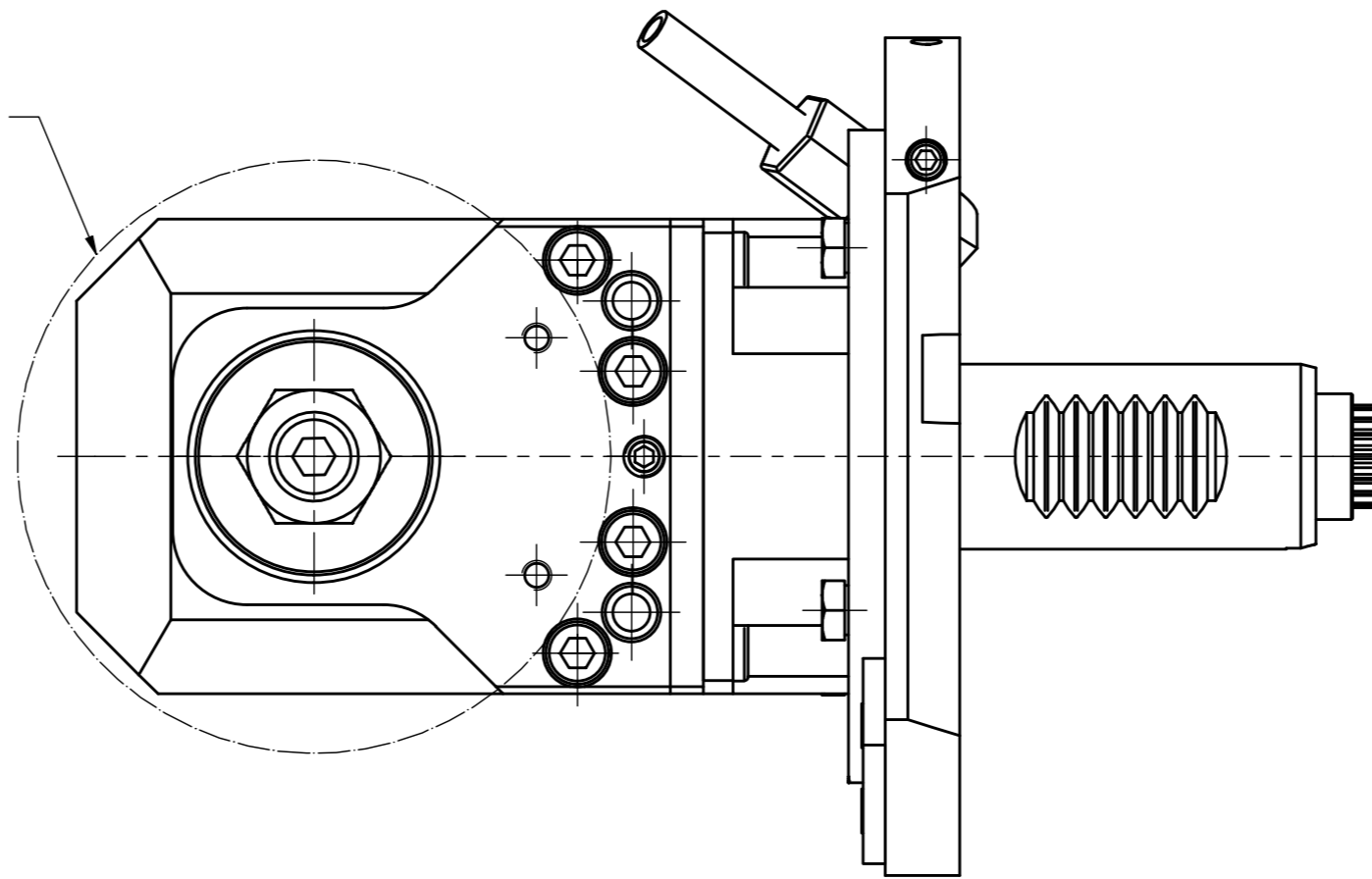

min. und max. Schwenkwinkel beziehen sich auf den Werkzeughalter.
Zusätzlich muss eine Kollisionsbetrachtung im Arbeitsraum durchgeführt werden!
min. and max. swiveling angle refer to the tool
in addition the work space of the machine has to be checked for interferences!

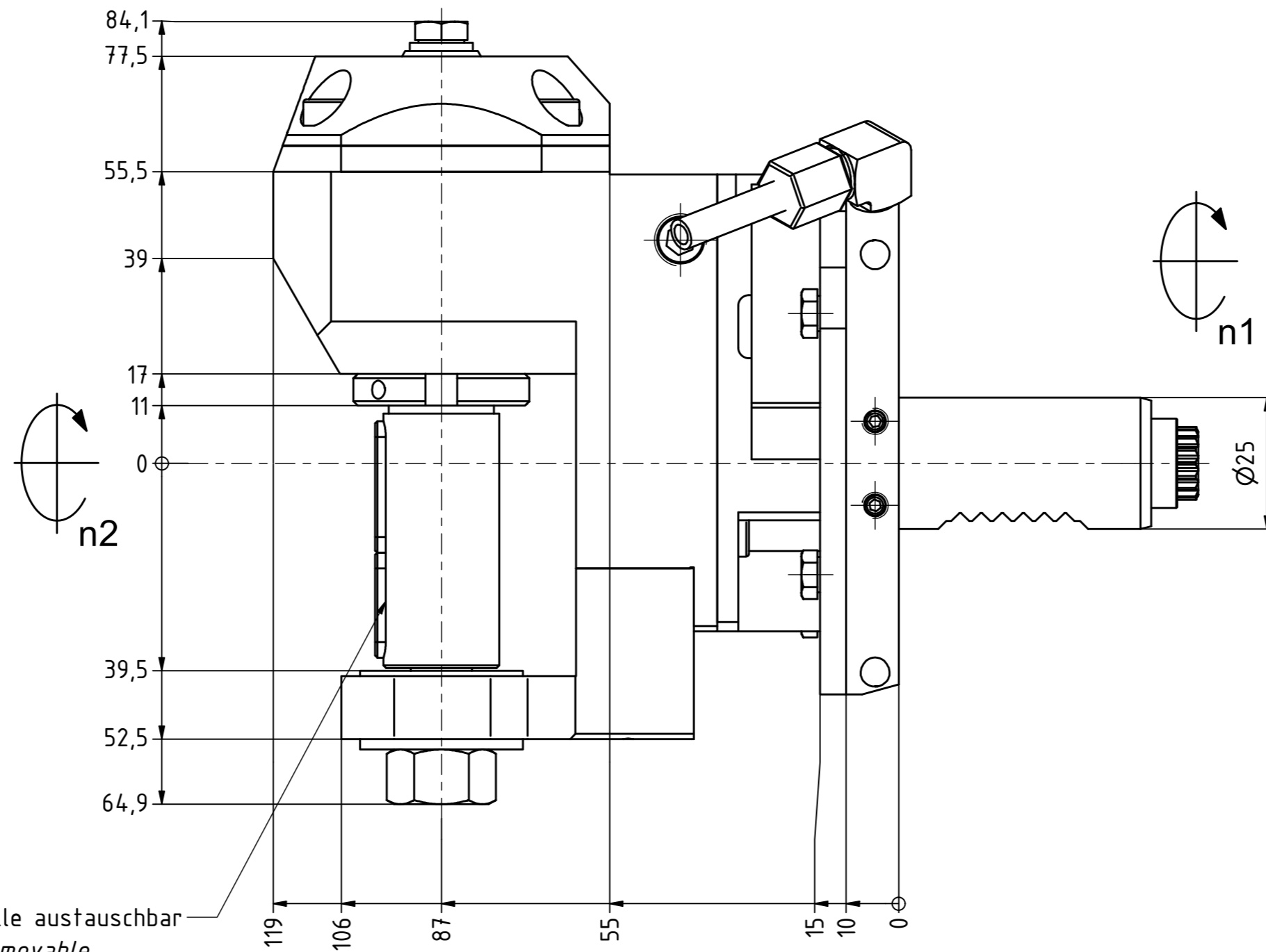
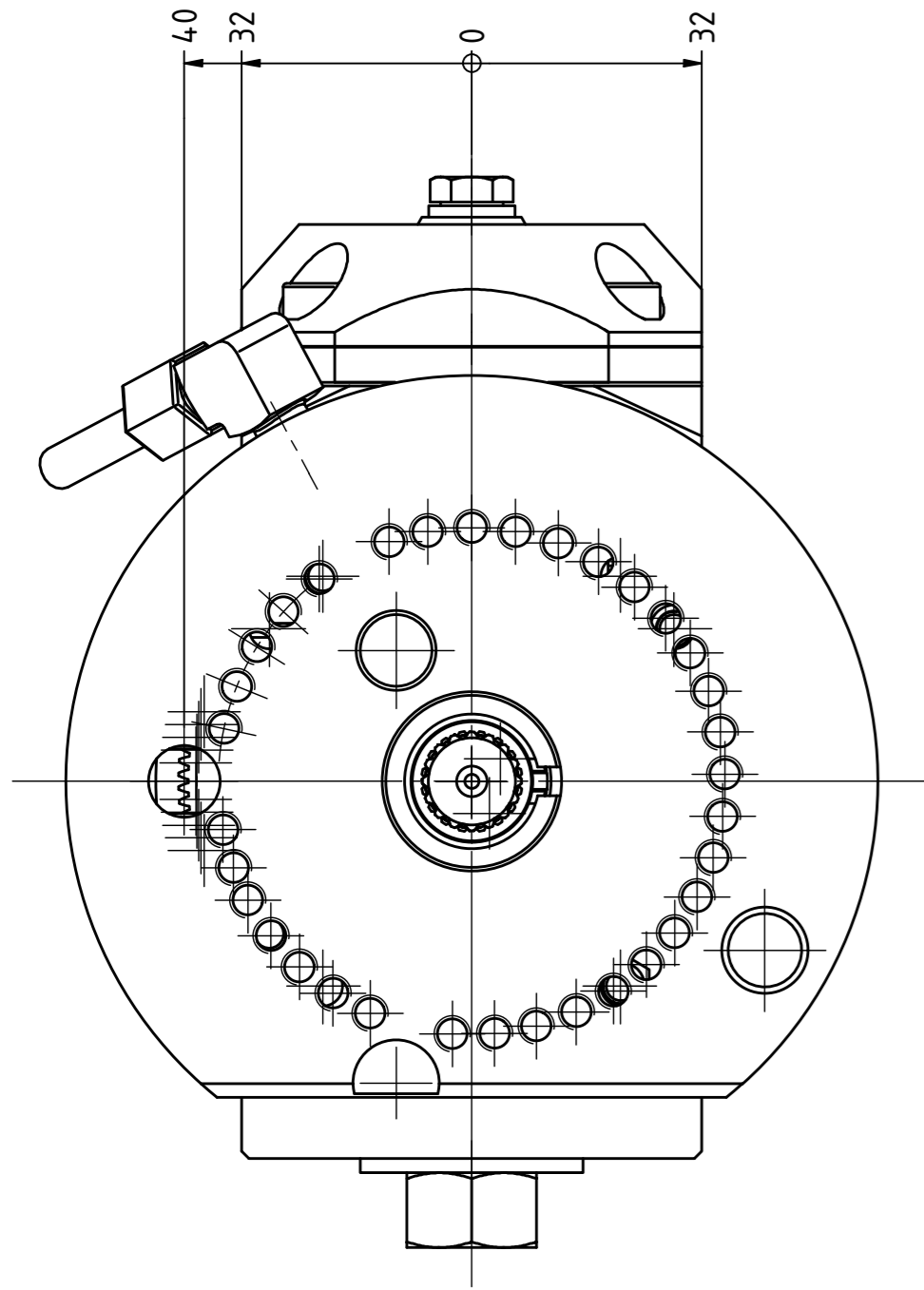

Beide Nachbarstationen nicht verwendbar!
both neighboring are not useable!

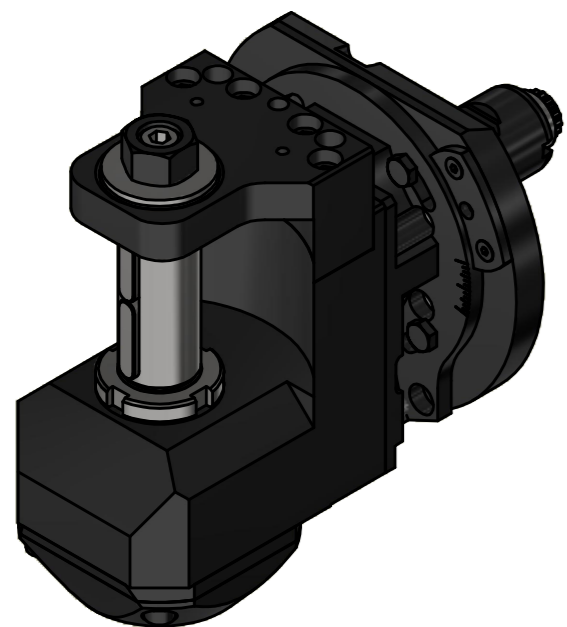
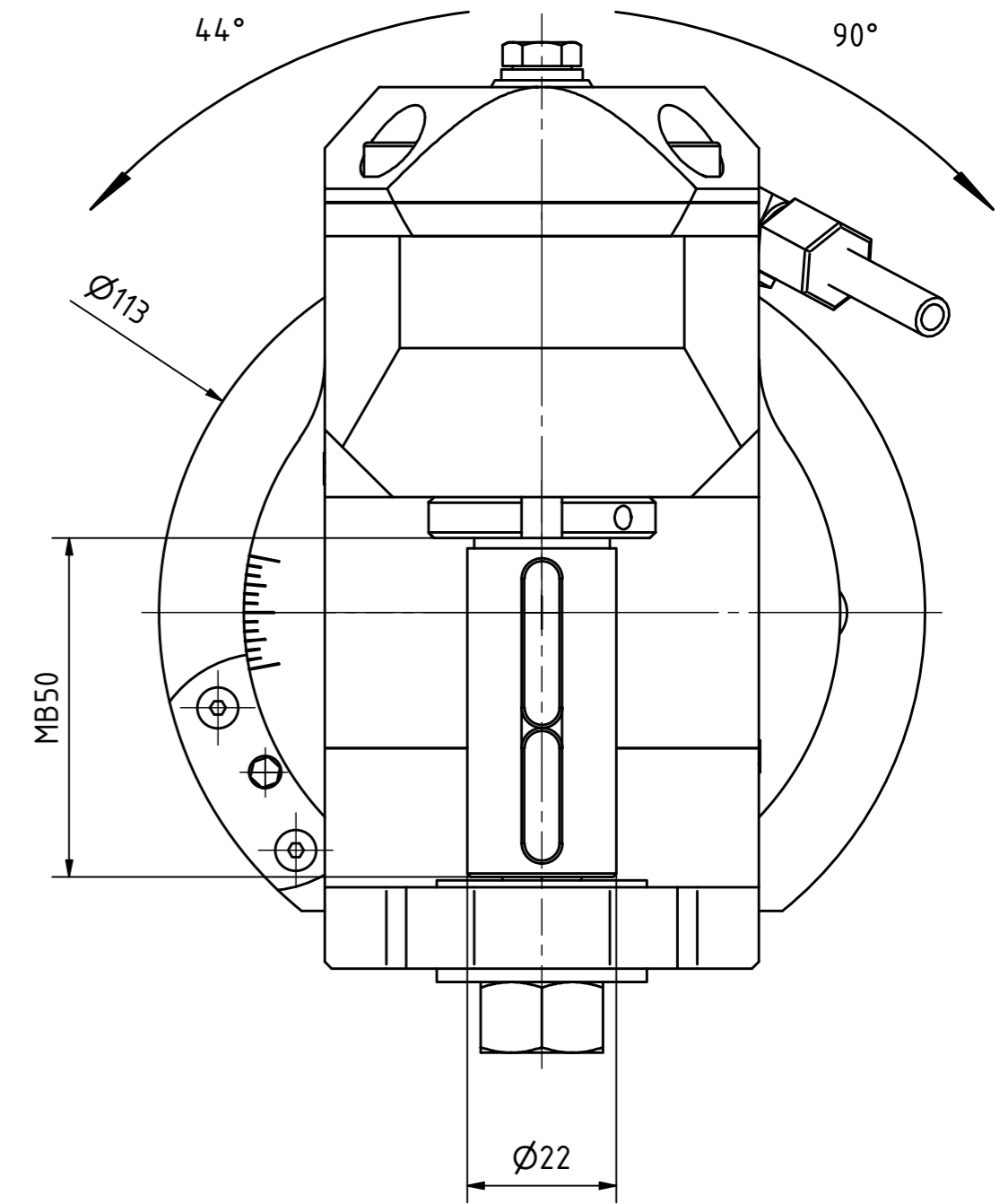

Fraeserwelle austauschbar
Spindle removable



Copyright **EWS Tool Technologies**
Weitergabe und Vervielfältigung dieser Unterlage,
Verwertung und Mitteilung ihres Inhalts nicht
gestattet, soweit nicht ausdrücklich zugestanden.
Zuwendungen verpflichten zu Schadenersatz.

Bemerkung - Note 	Technische Daten - technical data Weight = 4,413 [kg] Torque max. (M1/M2) = 20 / 60 [Nm] Speed max. (n1/n2) = 6000 / 2000 [1/min] Gear ratio (i)=n1:n2 = 3:1	Benennung - Title Scheibenfräserkopf Radial saw milling head	 EWS Weigle GmbH & Co. KG Maybachstr. 1 D-73066 Ulm/ingen www.ews-tools.de	Technische Änderungen vorbehalten! Subject to technical modifications! IDENT: DEWS150177 REV: -/B MNR. 139389	
----------------------	--	--	---	---	---