

max. Fraeserdurchmesser Ø80
max. saw milling diameter

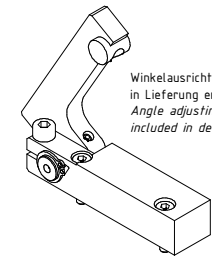

Winkelausrichtung & CD-ROM
in Lieferung enthalten!
Angle adjusting & CD-ROM
included in delivery!

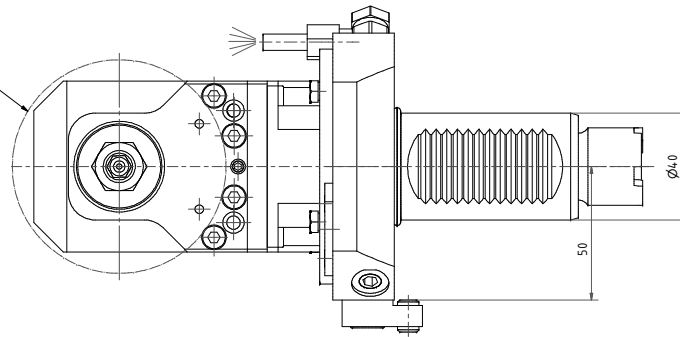
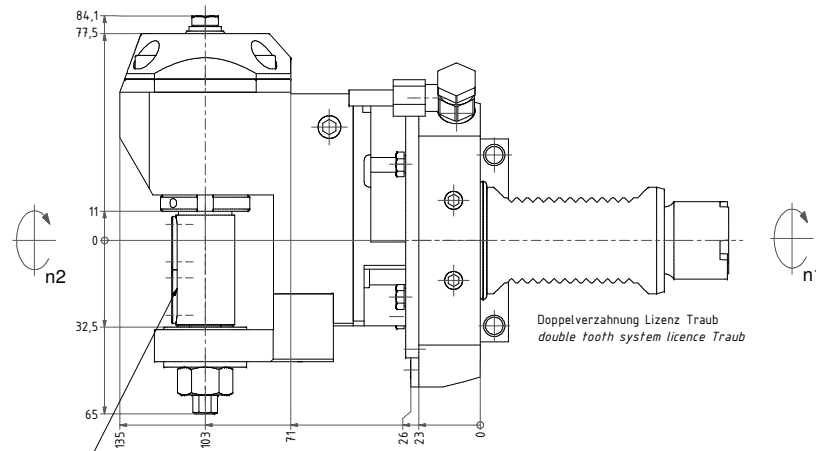
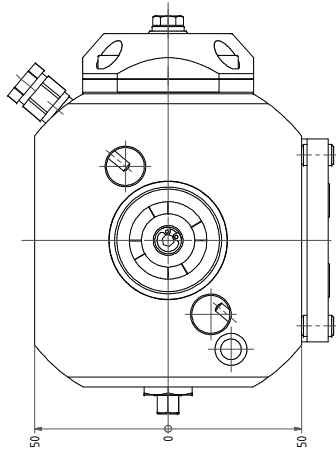

Fraeserwelle austauschbar
Spindle removable

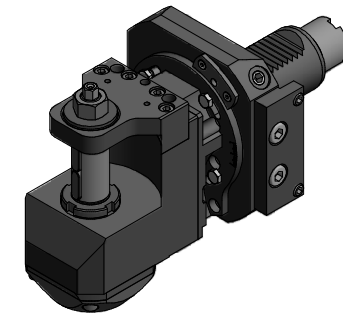
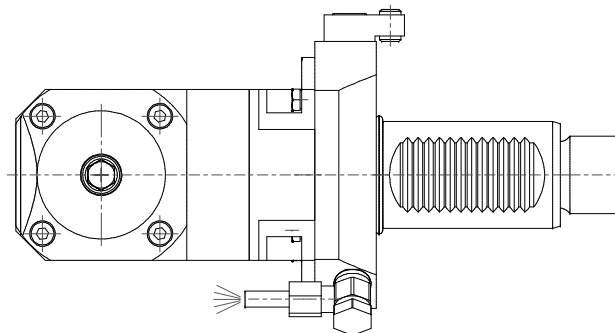
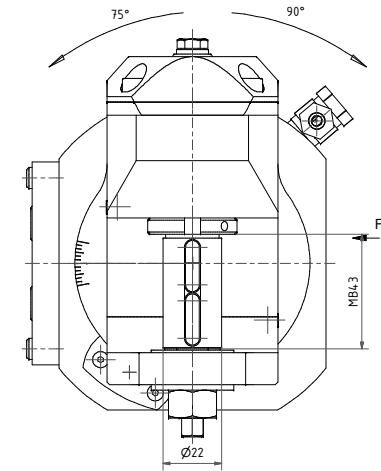

Beide Nachbarstationen nicht verwendbar!
both neighboring are not useable!

min. und max. Schwenkwinkel beziehen sich auf den Werkzeughalter.
Zusätzlich muss eine Kollisionsbetrachtung im Arbeitsraum durchgeführt werden!
min. and max. swiveling angle refer to the tool
in addition the work space of the machine has to be checked for interferences!

Bemerkung - Note

Technische Daten - Technical data
Weight = 6,030 [kg]
Torque max. (M1/M2) = 20 / 20 [Nm]
Speed max. (n1/n2) = 6000 / 6000 [1/min]
Gear ratio (i)=n1/n2 = 1:1

Bemerkung - Note

Copyright EWS Tool Technologies
Weitergabe und Vervielfältigung dieser Unterlage,
Veränderung und Mithaltung ihres Inhalts nicht
gestattet, soweit nicht ausdrücklich zugestanden.
Zuweiterhandlungen verpflichtet zu Schadensersatz.







64.4022LT15TKWMB43-BG30
 199939

