

Fraeserwelle austauschbar
Spindle removable

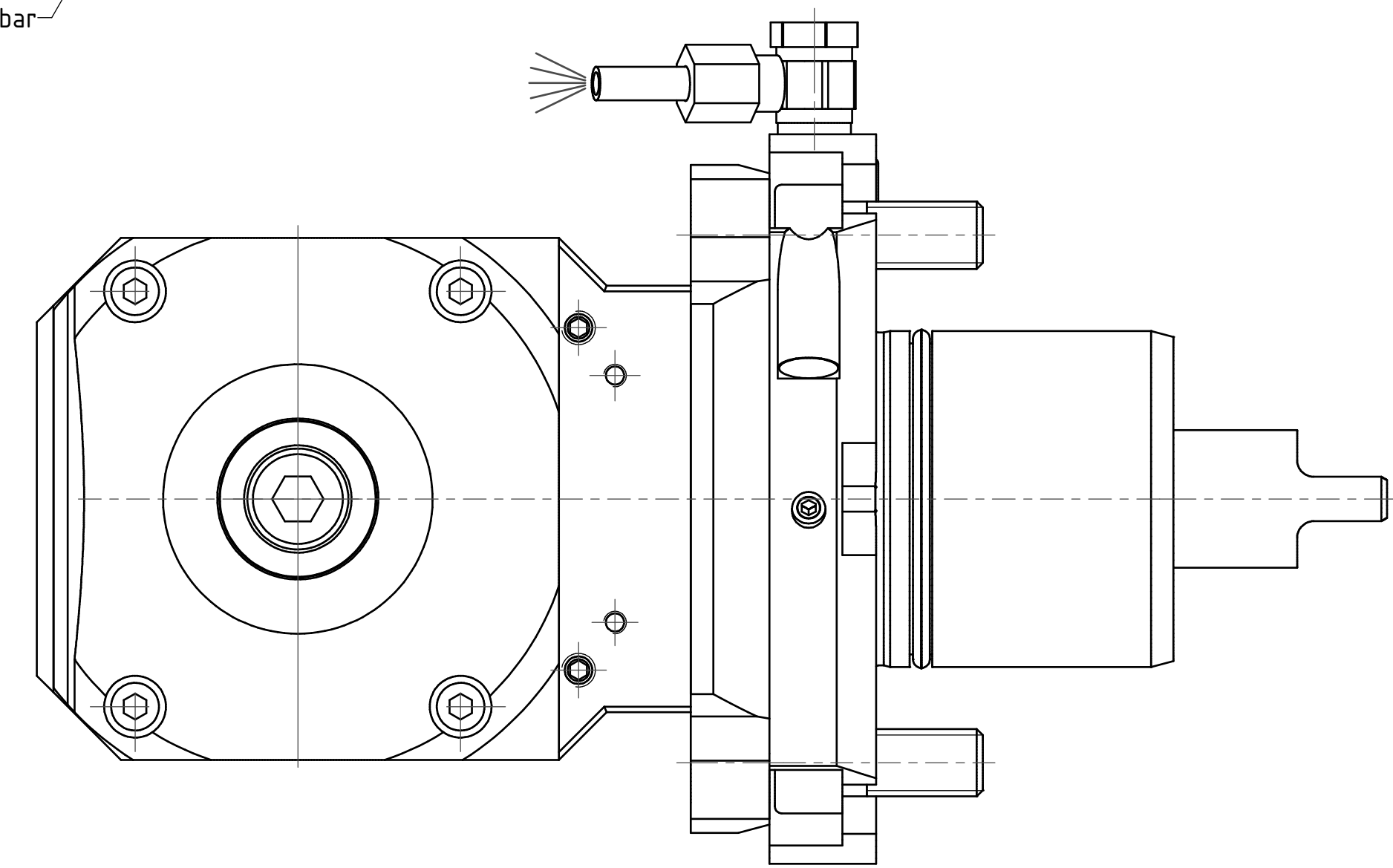
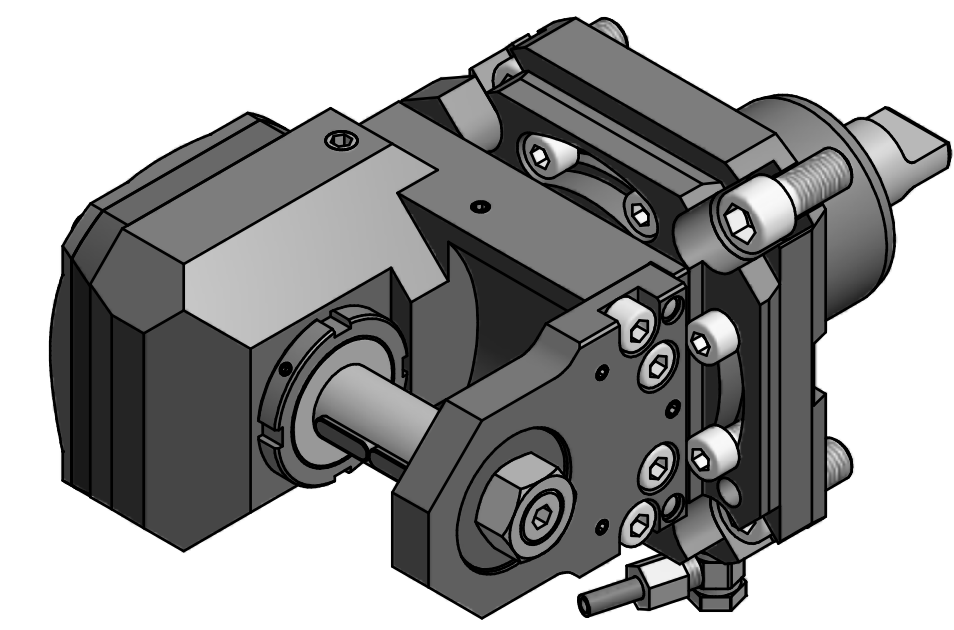

Achtung/Caution:
Dieses Werkzeug kann nur in der 0°-Position
montiert und demontiert werden, wie gezeichnet!
Somit ist eine Winkelverstellung nur möglich,
wenn das Werkzeug bereits auf der Maschine montiert ist.
*This tool can only be mounted and remounted
in 0° position, like drawn!*
*So, angle adjustment is only possible, when this tool
is already mounted on the machine!*

Copyright EWS Tool Technologies
Weitergabe und Vervielfältigung dieser Unterlage,
Verwertung und Mitteilung ihres Inhalts nicht
gestattet, soweit nicht ausdrücklich zugestanden.
Zu widerhandlungen verpflichten zu Schadenersatz.

Bemerkung - Note 	Technische Daten - technical data Weight = 9,755 [kg] Torque max. (M1/M2) = 50 / 150 [Nm] Speed max. (n1/n2) = 6000 / 2000 [1/min] Gear ratio (i)=n1:n2 = 3:1	Bezeichnung - Title Scheibenfräserkopf <i>Radial saw milling head</i>	EWS Werkzeug GmbH & Co. KG Hauptstr. 1 72706 Ulm www.ews.de Technische Änderungen vorbehalten! Subject to technical modifications! IDENT: D-EWS-016461 REV: A/- 64.6022NL13TKW 132827	
--------------------------	---	--	--	---