

Polygon ISO 26623 PSC 63

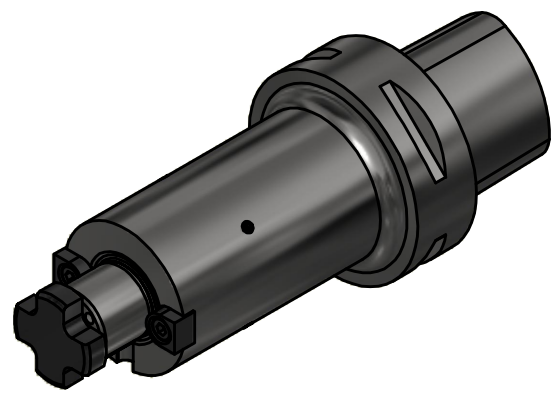

Copyright **EWS Tool Technologies**
 Weitergabe und Vervielfaeltigung dieser Unterlage,
 Verwertung und Mitteilung ihres Inhalts nicht
 gestattet, soweit nicht ausdrecklich zugestanden.
 Zuwiderhandlungen verpflichten zu Schadenersatz.

Bemerkung - Note	Technische Daten - technical data Weight = 1.780 [kg]	Benennung - Title Axial Fräsdornhalter <i>Axial milling arbor holder</i>	 EWS Weigle GmbH & Co. KG Maybachstr. 1 D-73066 Uhingen www.ews-tools.de	Technische Aenderungen vorbehalten! Subject to technical modifications! IDENT: D-EWS-051837	 REV: -/A MNR. S02384	
------------------	--	---	--	---	--	---