

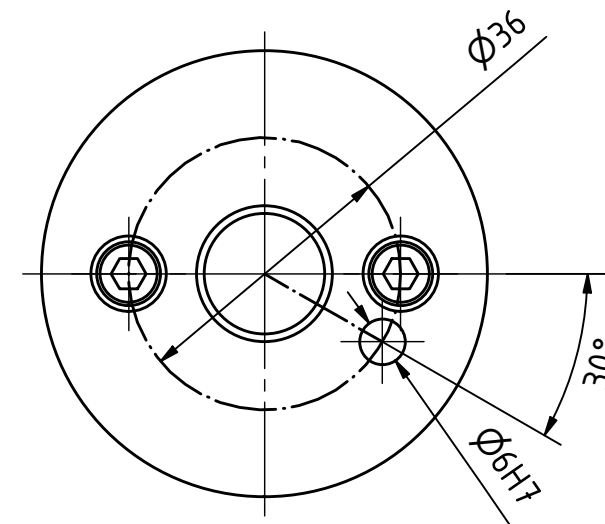

Polygon ISO 26623 PSC 50



Copyright **EWS Tool Technologies**
 Weitergabe und Vervielfaeltigung dieser Unterlage,
 Verwertung und Mitteilung ihres Inhalts nicht
 gestattet, soweit nicht ausdrecklich zugestanden.
 Zuwiderhandlungen verpflichten zu Schadenersatz.

Bemerkung - Note	Technische Daten - technical data Weight = 0.679 [kg]	Benennung - Title Bohrstangenhalter <i>Boring bar holder</i>	 EWS <small>Tool Technologies</small> EWS Weigle GmbH & Co. KG Maybachstr. 1 D-73066 Uhingen www.ews-tools.de	Technische Aenderungen vorbehalten! <i>Subject to technical modifications!</i> IDENT: DEWS239335 Nr. - No. 19.C516HYD	 REV: -/B MNR. S01058	
------------------	-----------------------------------------------------------------	---------------------------------------------------------------------------	--------------------------------------------------------------------------------------------------------------------------------------------------------------------------------------------------------------------------	------------------------------------------------------------------------------------------------------------------------------------------	----------------------------------------------------------------------------------------------------------------------------	---------------------------------------------------------------------------------------