

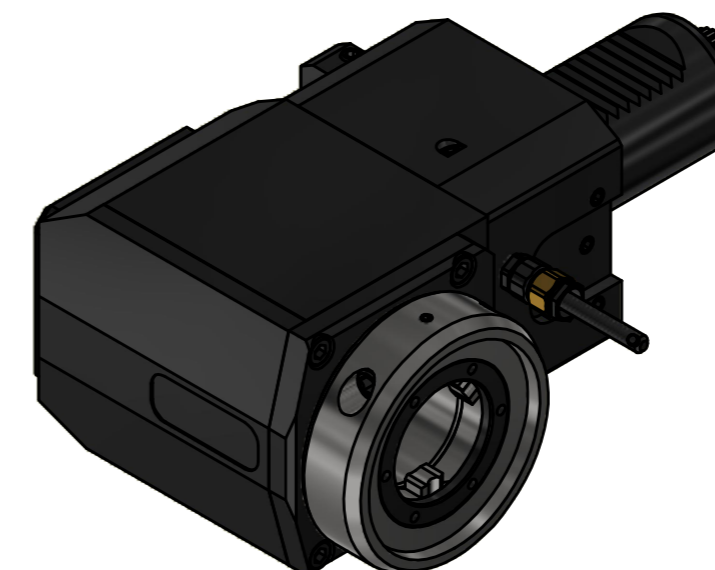

Doppelverzahnung Lizenz Traub  
double tooth system licence Traub



Copyright **EWS Tool Technologies**  
Weitergabe und Vervielfältigung dieser Unterlage,  
Verwertung und Mitteilung ihres Inhalts nicht  
gestattet, soweit nicht ausdrücklich zugestanden.  
Zu widerhandlungen verpflichten zu Schadenersatz.

Bemerkung - Note	Technische Daten - technical data Weight = 6.696 [kg] Torque max. (M1/M2) = 63 / 63 [Nm] Speed max. (n1/n2) = 6000 / 6000 [1/min] Gear ratio (i)=n1:n2 = 1:1	Benennung - Title <b>Radial Bohr und Fräskopf</b> <b>Radial drilling and milling head</b>	 EWS Weigle GmbH & Co. KG Maybachstr. 1 D-73066 Uhingen www.ews-tools.de Technische Änderungen vorbehalten! Subject to technical modifications! IDENT: DEWS269312 Nr. - No. 60.40VX4CTXRL#01 MNR. 220190	
------------------	--	---	---	---