

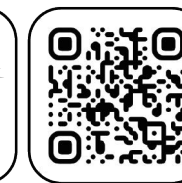

Highspeed

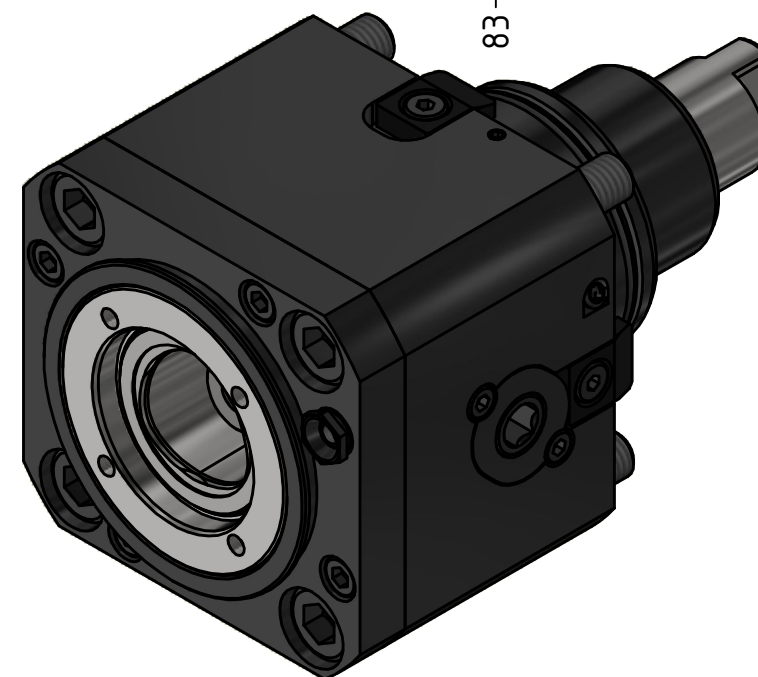

Tech Details

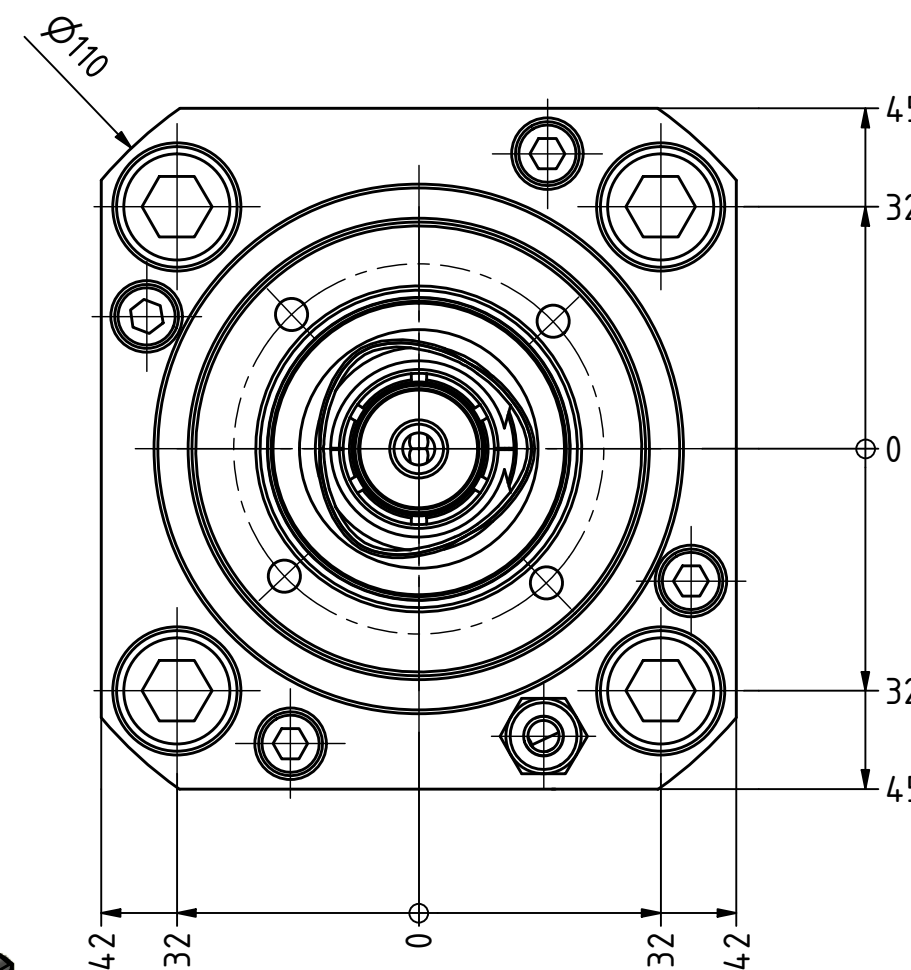
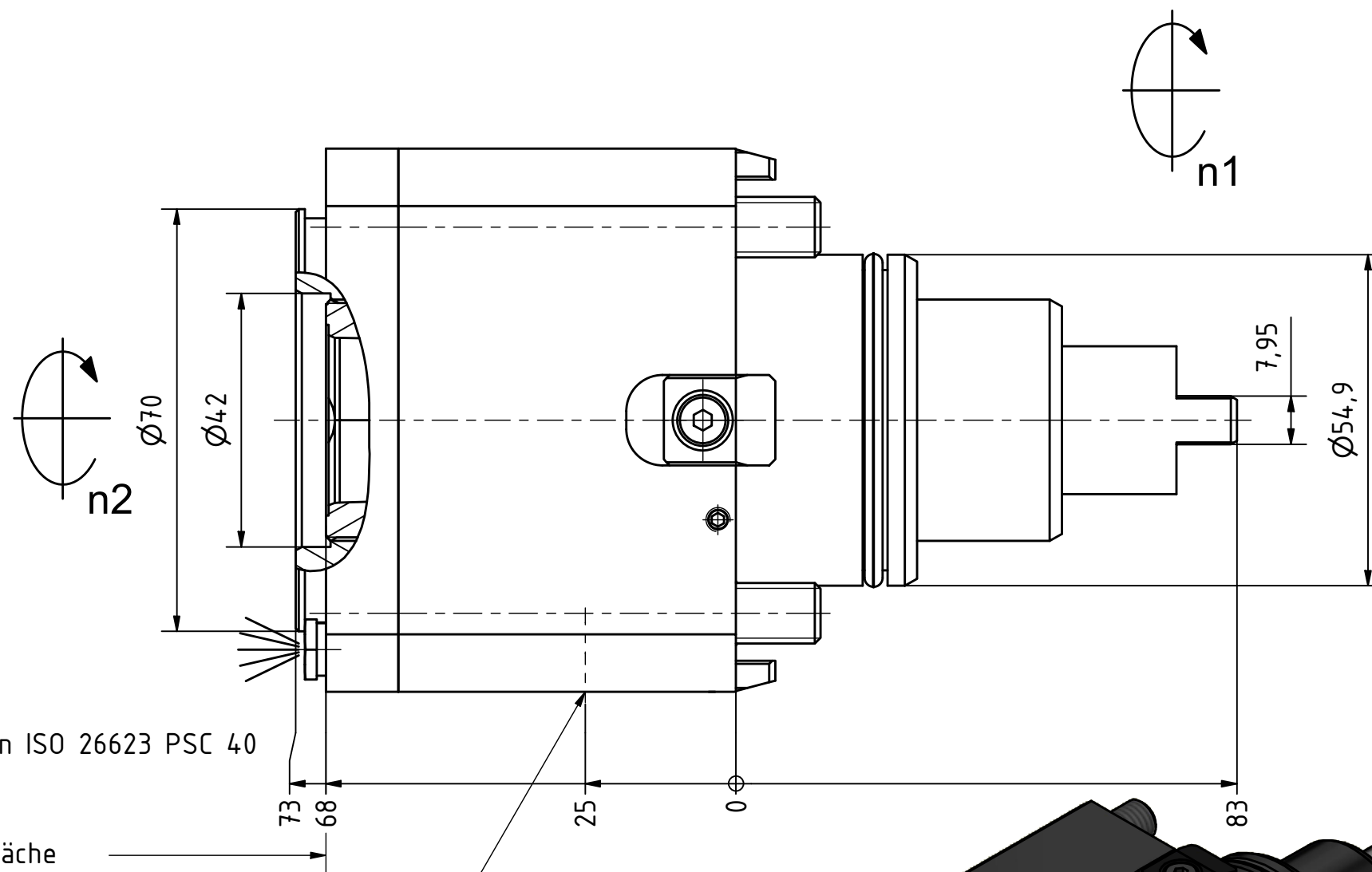

Polygon ISO 26623 PSC 40

Anlagefläche
contact surface

Anzugsdrehmoment 45Nm
Clamping torque 45Nm

Copyright **EWS Tool Technologies**

Weitergabe und Vervielfältigung dieser Unterlage, Verwertung und Mitteilung ihres Inhalts nicht gestattet, soweit nicht ausdrücklich zugestanden. Zuwiderhandlungen verpflichten zu Schadenersatz.

Bemerkung - Note

Technische Daten - technical data

Weight = 4.139 [kg]
Torque max. (M1/M2) = 50 / 50 [Nm]
Speed max. (n1/n2) = 12000 / 12000 [1/min]
Gear ratio (i)=n1:n2 = 1:1

Benennung - Title

Axial Bohr und Fräskopf
Axial drilling and milling head



Nr. - No.
40.55C4VL2HSD12

Technische Änderungen vorbehalten!
Subject to technical modifications!

IDENT: DEWS240538



REV: -/C

MNR.

219587

