

Spannzange / collet ER32 DIN6499
 Spannbereich / clamping range: 2,0 - 20,0



Highspeed



Tech Details

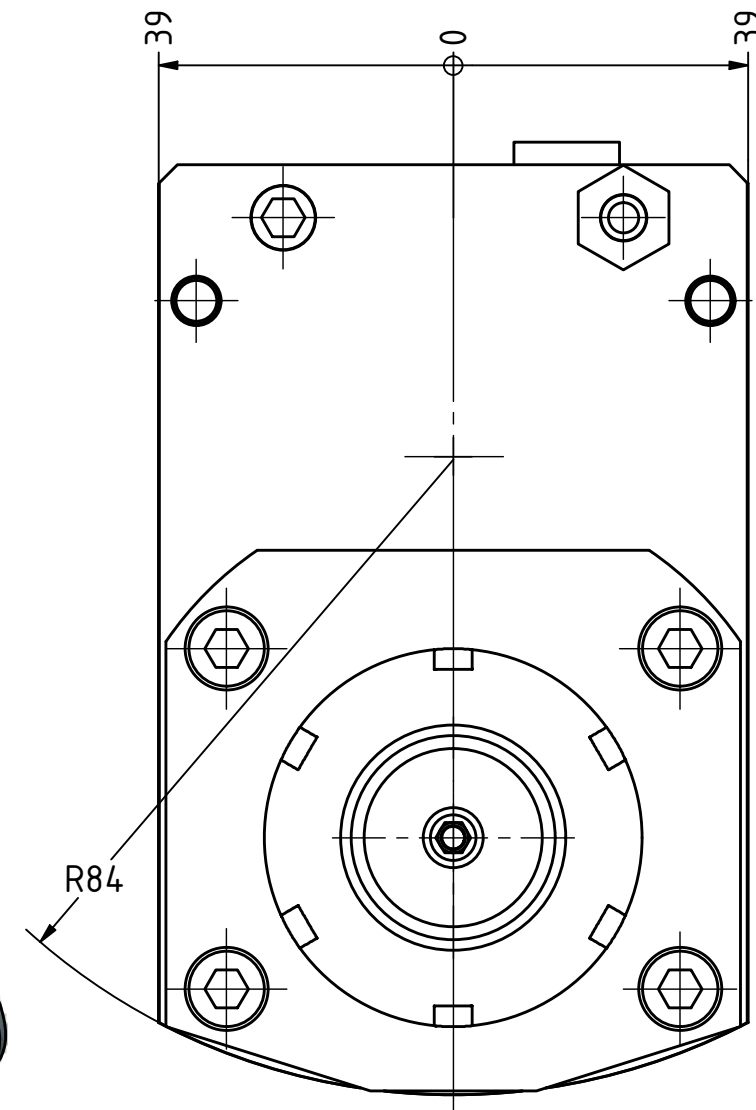
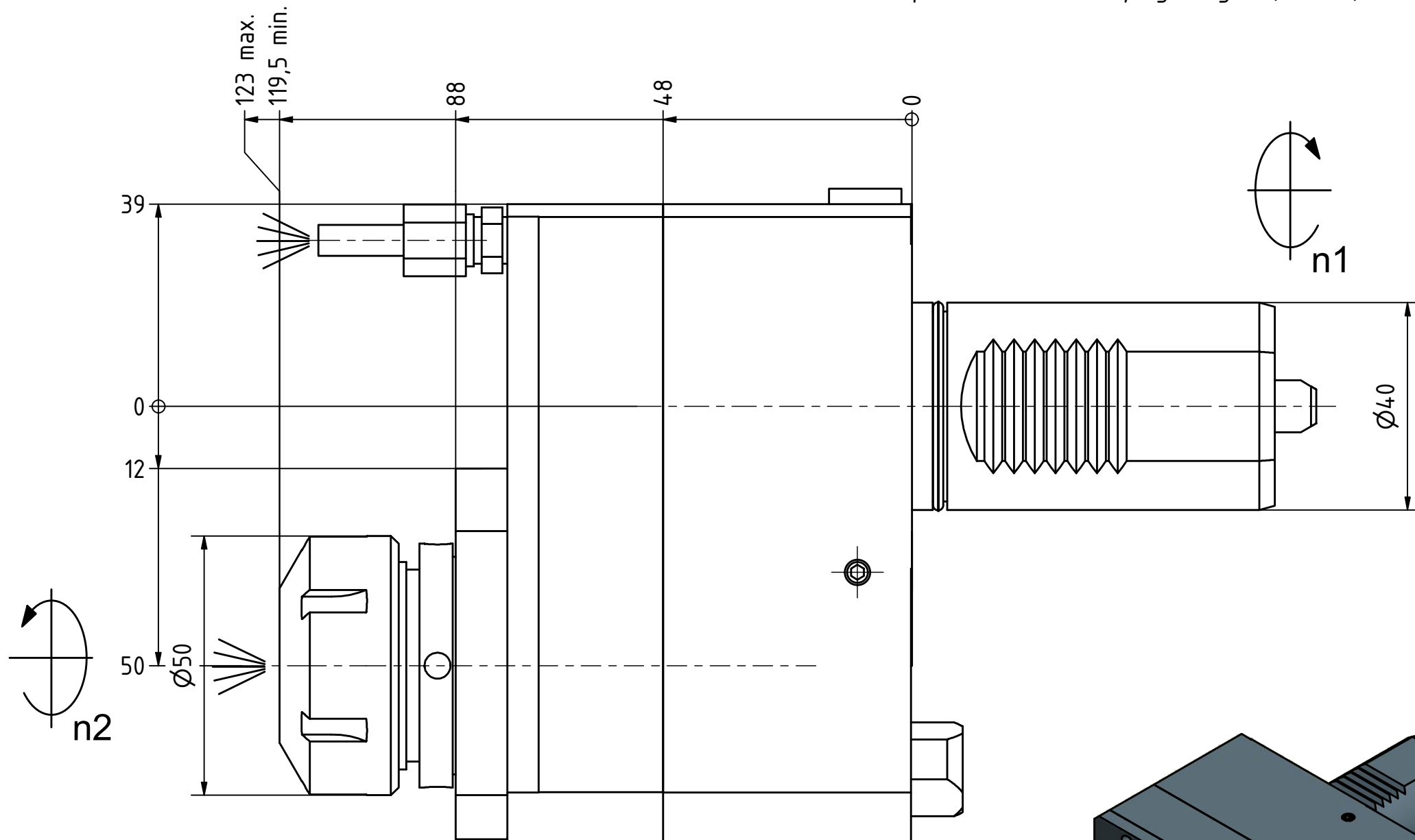

Spannzange / collet ER32 DIN6499
 Spannbereich / clamping range: 2,0 - 20,0

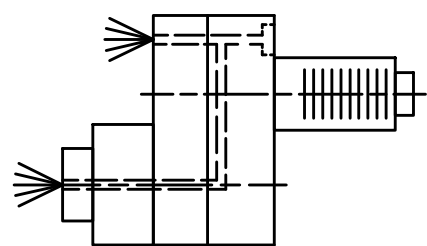
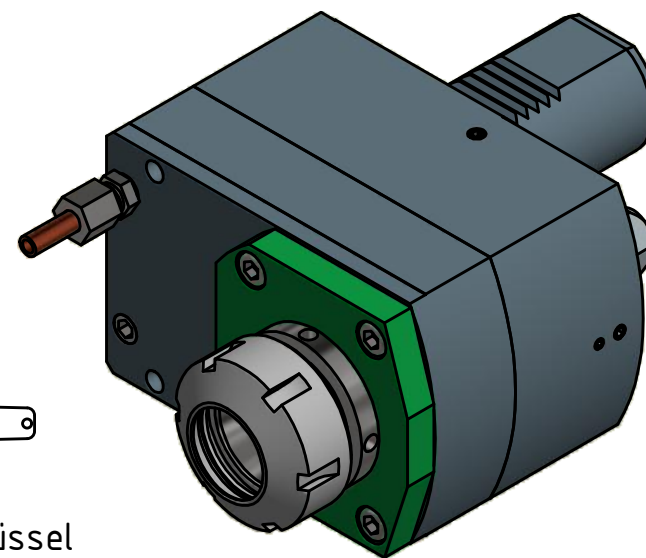

Innen- und Aussenkuehlung / Inside and outside coolant supply
 Kein Trockenlauf / No dry run
 Kuehlmittelfiltrierung <math>< 50\mu</math> / coolant filtration <math>< 50\mu</math>

 Hakenschlüssel
 mit Zapfen
 Hook wrench
 with fixed pin
 DIN1810 B 45x50

 Spannzangenschlüssel
 Clamping wrench
 232

Copyright **EWS Tool Technologies**
 Weitergabe und Vervielfaeltigung dieser Unterlage,
 Verwertung und Mitteilung ihres Inhalts nicht
 gestattet, soweit nicht ausdrecklich zugestanden.
 Zuwiderhandlungen verpflichten zu Schadenersatz.

Bemerkung - Note
 Nicht ohne Kuehlmittel betreiben!
 Not for use without coolant-fluid!

Technische Daten - technical data
 Weight = 6.209 [kg]
 Torque max. (M1/M2) = 50 / 50 [Nm]
 Speed max. (n1/n2) = 10000 / 10000 [1/min]
 Gear ratio (i)=n1:n2 = 1:1
 Pressure (pmax) = 70 [bar]

Benennung - Title
 Axial Bohr u. Fräskopf achsversetzt
 Ax. drill. and mill. head offset

EWS Tool Technologies
 EWS Weigele GmbH & Co. KG
 Maybachstr. 1
 D-73066 UHINGEN
 www.ews-tools.de

Technische Aenderungen vorbehalten!
 Subject to technical modifications!
 IDENT: DEWS105115
 Nr. - No. 50.4032MP620RIKHSD10

REV: -/A
 MNR. 219584

