

Spannzange / collet ER32 DIN6499  
 Spannbereich / clamping range: 2,0 - 20,0

Gewindebohrzange / tapping collet  
 ET-1-32 M5-M12

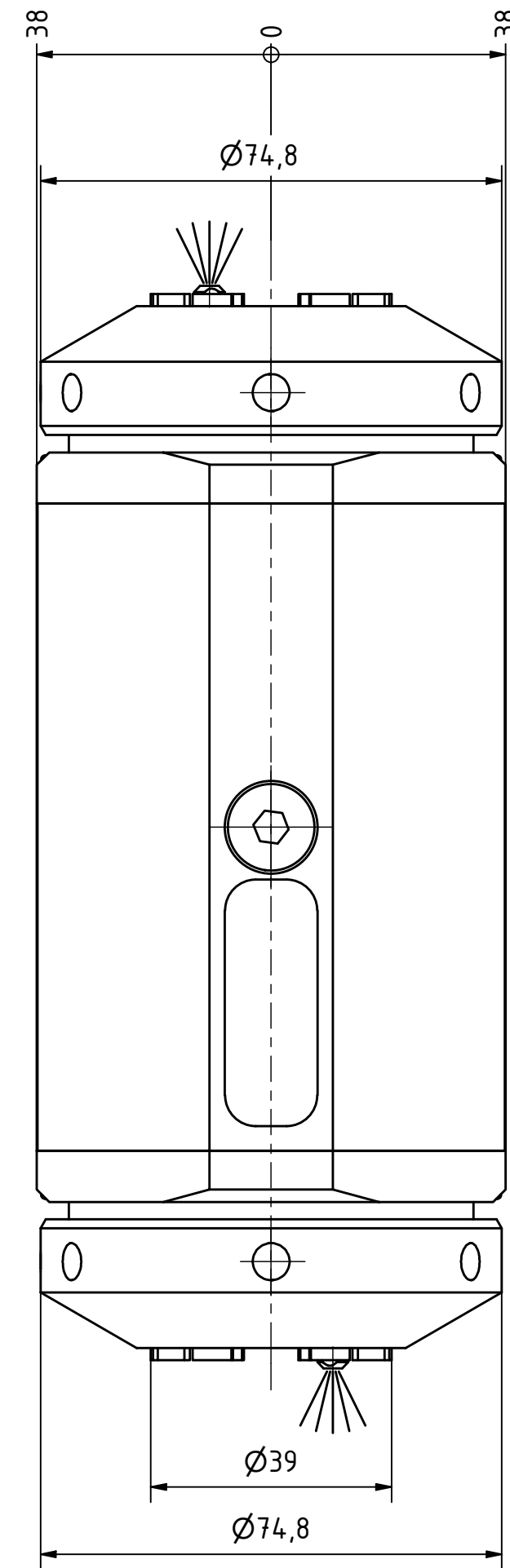
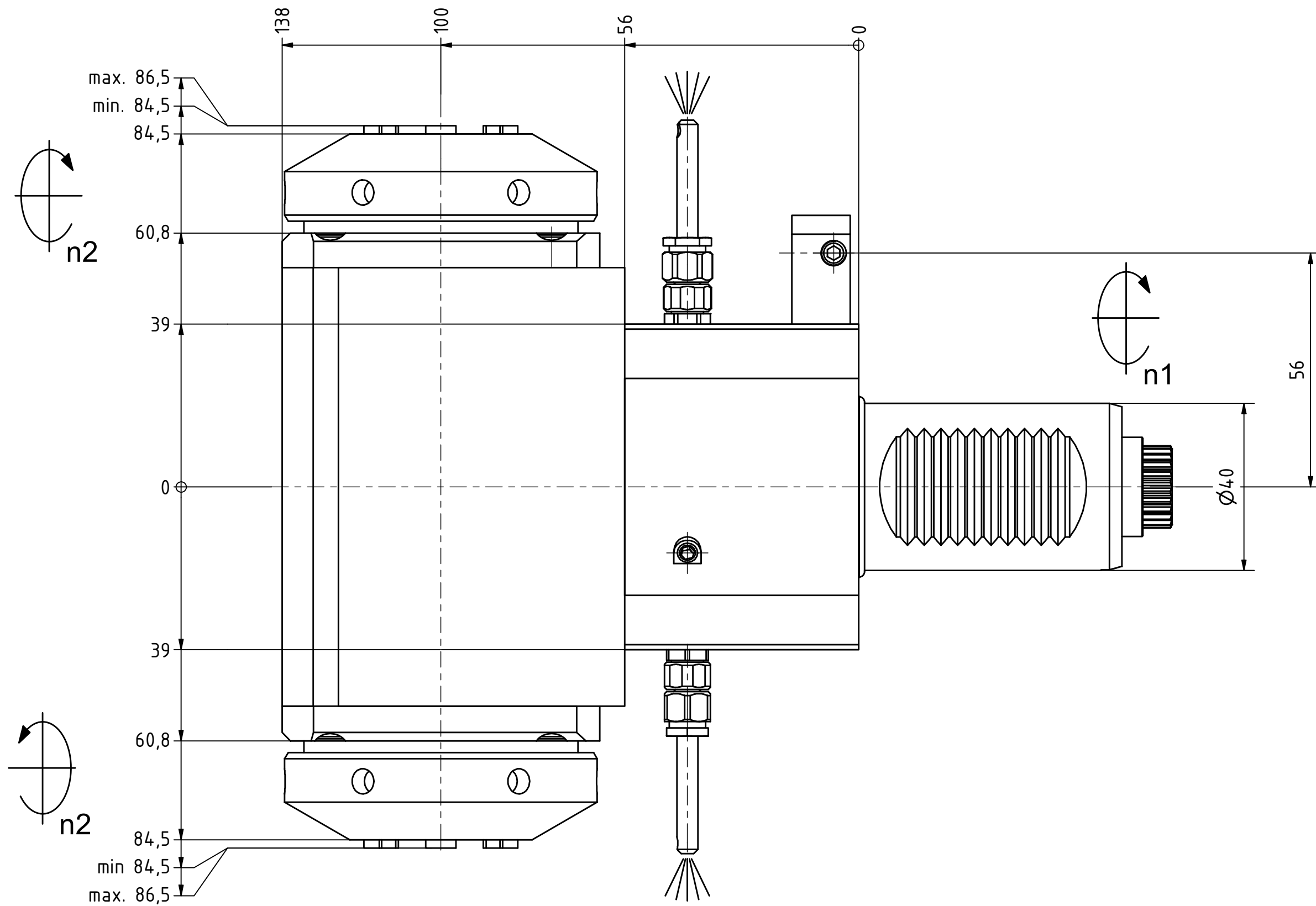
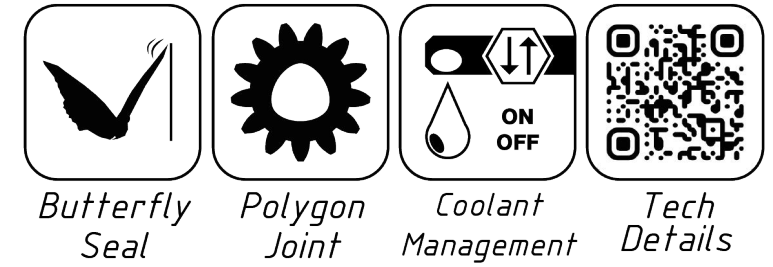

Spannzange / collet ER32 DIN6499  
 Spannbereich / clamping range: 2,0 - 20,0

Gewindebohrzange / tapping collet  
 ET-1-32 M5-M12

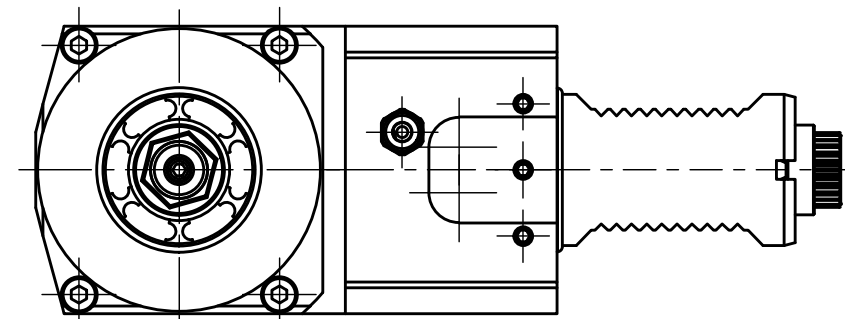

Doppelverzahnung Lizenz Traub  
 double tooth system licence Traub

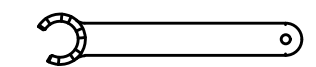
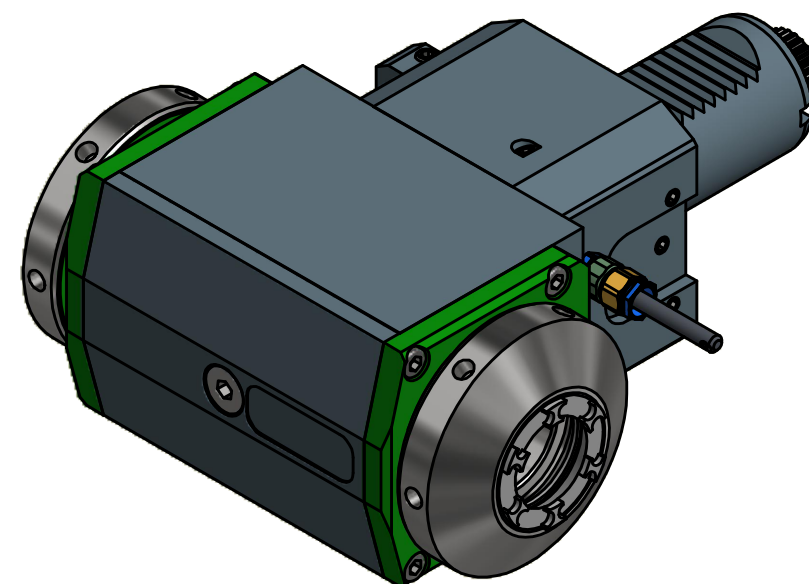

Spannzangenschlüssel für innenliegende Mutter  
 Clamping wrench for internal collet  
 232AX

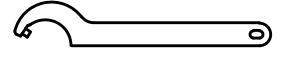

Hakenschlüssel mit Zapfen  
 Hook wrench with fixed pin  
 DIN1810 B 68x75

Copyright EWS Tool Technologies  
 Weitergabe und Vervielfältigung dieser Unterlage,  
 Verwertung und Mitteilung ihres Inhalts nicht  
 gestattet, soweit nicht ausdrücklich zugestanden.  
 Zuwiderhandlungen verpflichten zu Schadenersatz.

Bemerkung - Note	Technische Daten - technical data Weight = 8.352 [kg] Torque max. (M1/M2) = 63 / 63   63 [Nm] Speed max. (n1/n2) = 6000 / 6000   6000 [1/min] Gear ratio (i)=n1:n2 = 1:1   1:1	Benennung - Title <b>Radial Bohr und Fräskopf</b> <i>Radial drilling and milling head</i>	 EWS Weigle GmbH & Co. KG Maybachstr. 1 D-73066 Uhlingen www.ews-tools.de	Technische Änderungen vorbehalten! Subject to technical modifications! IDENT: DEWS107401 REV: -/A	 <b>QR</b> Nr. - No. 60.4032DCTXRLIM#01 MNR. 220282
------------------	--	---	---	--	--