

Spannzange / collet ER20 DIN6499  
 Spannereich / clamping range: 1,0 - 13,0

Gewindebohrzange / tapping collet  
 ET-1-20 M2-M6

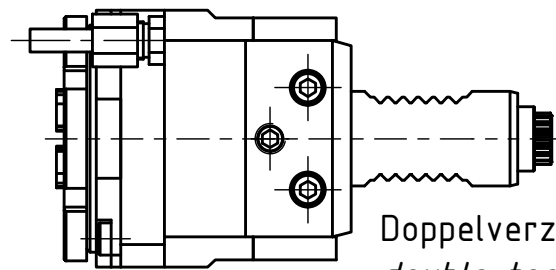

Doppelverzahnung Lizenz Traub  
 double tooth system licence Traub

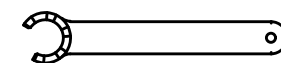
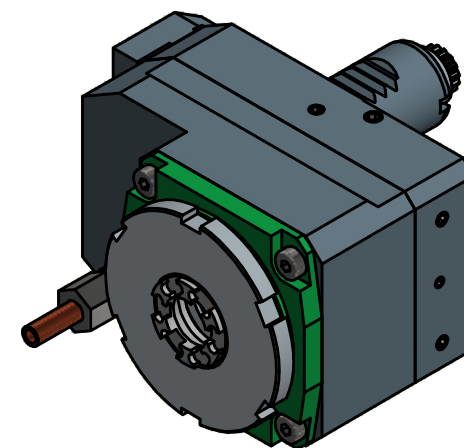

Spannzangenschlüssel für  
 innenliegende Mutter  
 Clamping wrench for  
 internal collet  
 220AX

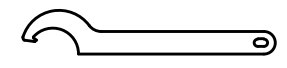

Hakenschlüssel  
 mit Nase  
 Hook wrench with  
 nose end  
 DIN1810 A 58x62

Copyright **EWS Tool Technologies**  
 Weitergabe und Vervielfältigung dieser Unterlage,  
 Verwertung und Mitteilung ihres Inhalts nicht  
 gestattet, soweit nicht ausdrücklich zugestanden.  
 Zuwiderhandlungen verpflichten zu Schadenersatz.

Bemerkung - Note

Technische Daten - technical data

Weight	= 3.023 [kg]
Torque max. (M1/M2)	= 24 / 12 [Nm]
Speed max. (n1/n2)	= 6000 / 12000 [1/min]
Gear ratio (i)=n1:n2	= 1:2

Benennung - Title

**Axial Bohr u. Fräskopf achsversetzt**  
**Ax. drill. and mill. head offset**

**EWS** Tool Technologies  
 EWS Weigle GmbH & Co. KG  
 Maybachstr. 1  
 D-73066 UHINGEN  
 www.ews-tools.de

Nr. - No.  
**50.2520E332RLI1M**

Technische Änderungen vorbehalten!  
 Subject to technical modifications!

IDENT: DEWS102612

MNR.  
**219076**

REV: -/A

