

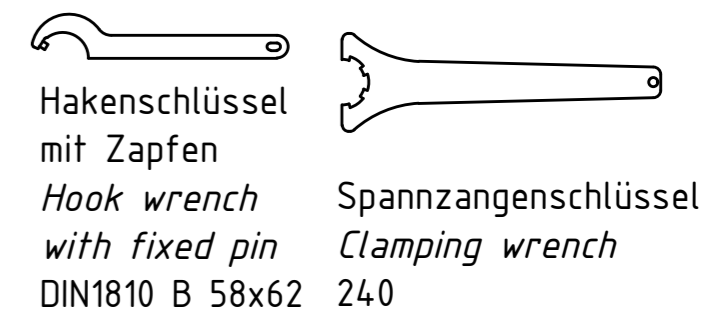

min. 97,5  
max. 101,0

Spannzange / collet ER40 DIN6499  
Spannbereich / clamping range: 3,0 - 26,0

Gewindebohrzange / tapping collet  
ET-1-40 M6-M16

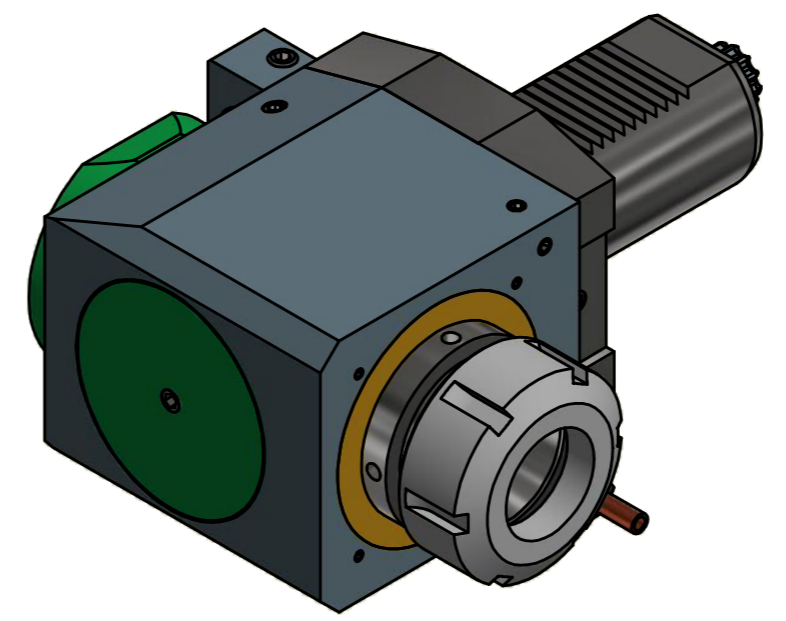

Copyright **EWS Tool Technologies**  
Weitergabe und Vervielfältigung dieser Unterlage, Verwertung und Mitteilung ihres Inhalts nicht gestattet, soweit nicht ausdrücklich zugestanden. Zuwiderhandlungen verpflichten zu Schadenersatz.

Bemerkung - Note	Technische Daten - technical data <b>Weight</b> = 8.308 [kg] <b>Torque max.</b> (M1/M2) = 100 / 100 [Nm] <b>Speed max.</b> (n1/n2) = 4000 / 4000 [1/min] <b>Gear ratio</b> (i)=n1:n2 = 1:1	Benennung - Title <b>Radial Bohr und Fräskopf</b> <i>Radial drilling and milling head</i>	 <b>EWS</b> Weigle GmbH & Co. KG Maybachstr. 1 D-73066 Uhingen www.ews-tool.de Nr. - No. <b>60.504.054.82R</b>	Technische Änderungen vorbehalten! <i>Subject to technical modifications!</i> IDENT: DEWS100518 MNR. REV: -/A <b>218723</b>	
------------------	--	---	--	--	---