

Spannzange / collet ER40 DIN6499  
Spannbereich / clamping range: 3,0 - 26,0

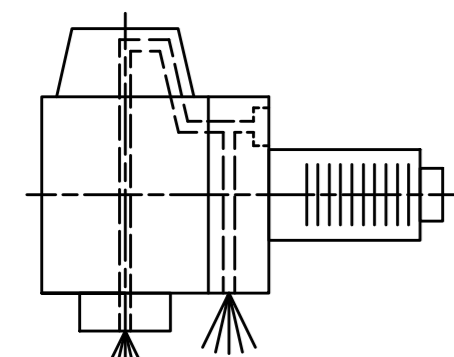

Innen- und Aussenkuehlung / Inside and outside coolant supply  
Kuehlmittelfiltrierung-50µ / coolant filtration-50µ

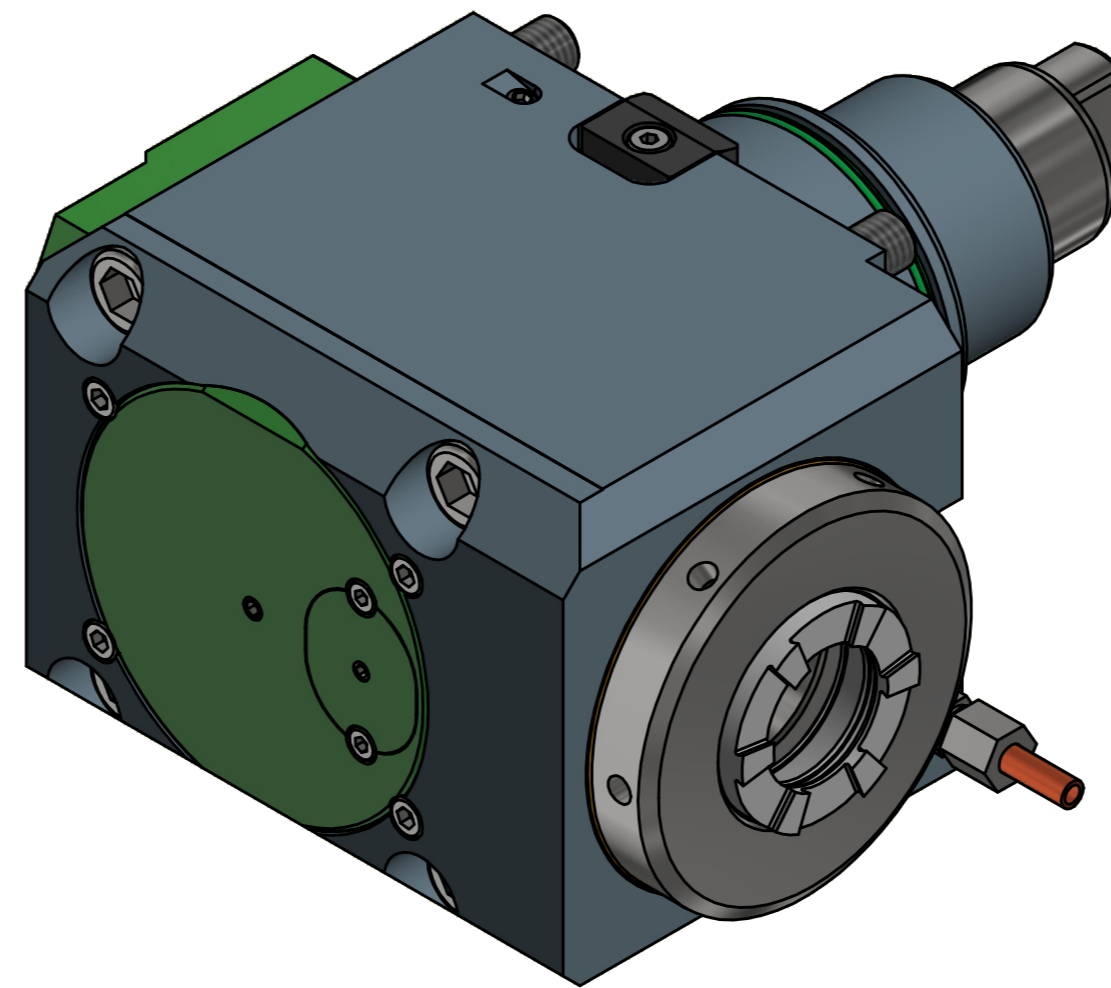
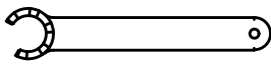

  
Hakenschlüssel  
mit Zapfen  
Hook wrench  
with fixed pin  
DIN1810 B 80x90

  
Spannzangenschlüssel für  
innenliegende Mutter  
Clamping wrench for  
internal collet  
240AX

Copyright **EWS Tool Technologies**  
Weitergabe und Vervielfaeltigung dieser Unterlage,  
Verwertung und Mitteilung ihres Inhalts nicht  
gestattet, soweit nicht ausdrecklich zugestanden.  
Zuwiderhandlungen verpflichten zu Schadenersatz.

Benennung - Title	Technische Daten - technical data
Für Trockenlauf geeignet! Use without coolant fluid allowed!	Weight = 13.739 [kg]
mit Kegelrollenlager with taper roller bearing(s)	Torque max. (M1/M2) = 80 / 160 [Nm]
	Speed max. (n1/n2) = 6000 / 3000 [1/min]
	Gear ratio (i)=n1:n2 = 2:1
	Pressure (pmax) = 70 [bar]

Benennung - Title  
**Radial Bohr und Fräskopf**  
**Radial drilling and milling head**

 <small>EWS Weigle GmbH &amp; Co. KG Maybachstr. 1 D-73066 Uhlingen www.ews-tools.de</small>	<small>Technische Aenderungen vorbehalten!</small> <small>Subject to technical modifications!</small>	 <b>QR</b>
	<small>IDENT: DEWS089258</small>	
<small>Nr. - No.</small> <b>60.7540KRVL8IKDI2IM-RF</b>		