

Spannzange / Collet ER16 DIN6499
 Spannbereich / Clamping range: 1,0 - 10,0

Gewindebohrzange / Tapping Collet
 ET-1-16 M1-M6

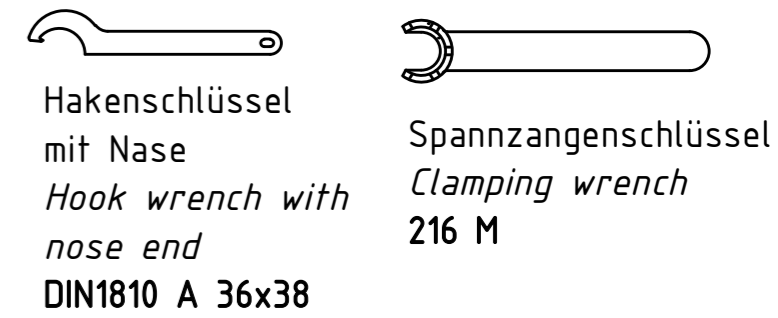
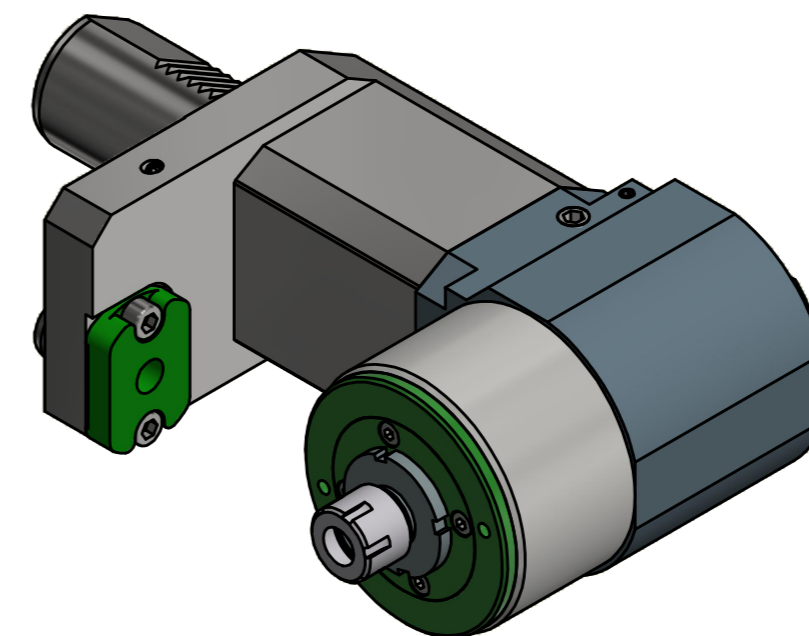
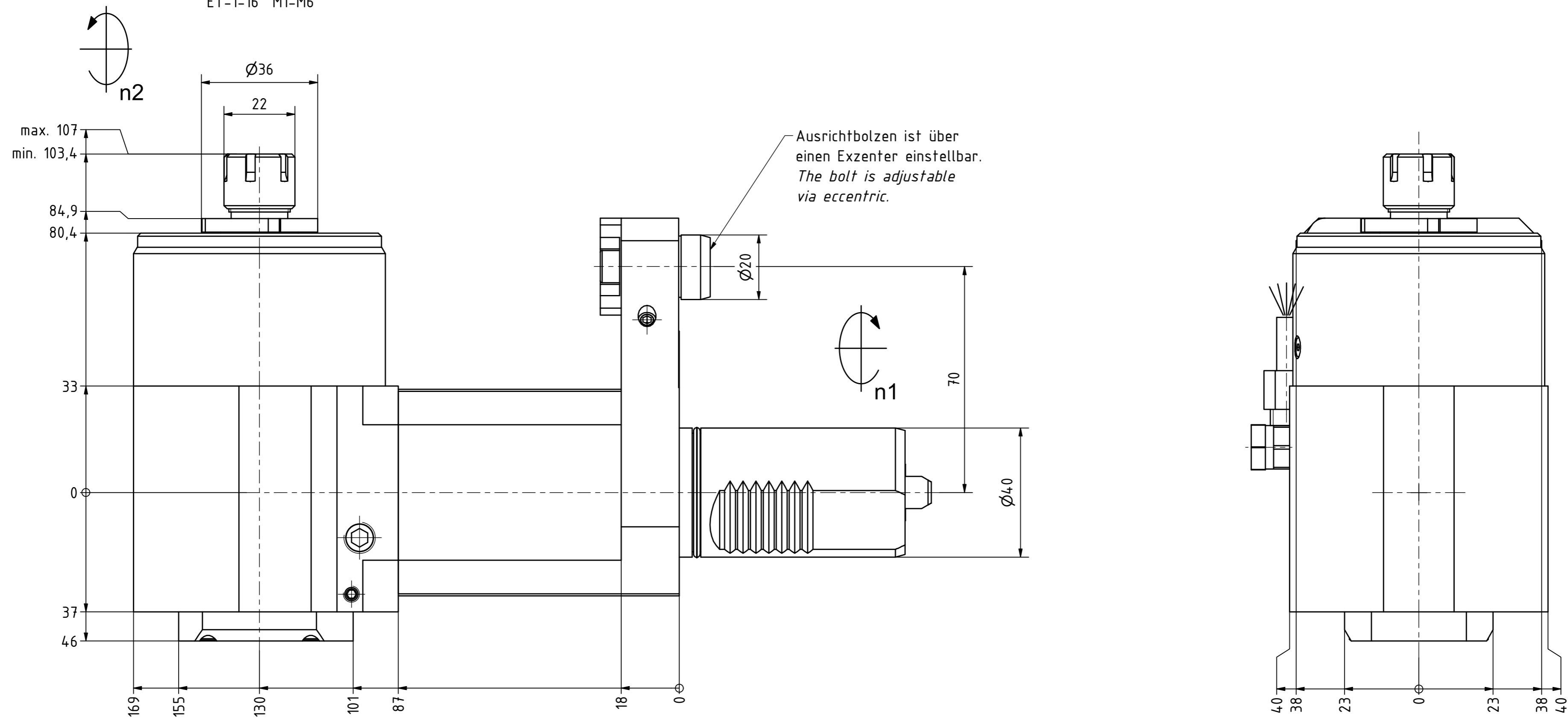

Fettschmierung mit Klüber Isoflex NCA 15
 Alle 100 Betriebsstunden mit ca. 1cm³ Fett nachschmieren
 Grease lubrication with Klüber Isoflex NCA 15
 relubricate every 100 operating hours with about 1cm³ of grease

Copyright EWS Tool Technologies
 Weitergabe und Vervielfältigung dieser Unterlage,
 Verwertung und Mitteilung ihres Inhalts nicht
 gestattet, soweit nicht ausdrücklich zugestanden.
 Zuwiderhandlungen verpflichten zu Schadenersatz.

Bemerkung - Note	Technische Daten - technical data Weight = 7.892 [kg] Torque max. (M1/M2) = 25 / 5 [Nm] Speed max. (n1/n2) = 4800 / 24.000 [1/min] Gear ratio (i)=n1:n2 = 1:5	Benennung - Title Radial Bohr und Fräskopf Radial drilling and milling head	EWS Tool Technologies EWS Weigle GmbH & Co. KG Maybachstr. 1 D-73066 Uhlingen www.ews-tool.de	Technische Änderungen vorbehalten! Subject to technical modifications! IDENT: DEWS062294 Nr. - No. 60.4016SQT15L15#01	MNR. REV: -/A 211911	
------------------	---	--	---	---	----------------------------	--