

Spannzange / collet ER32 DIN6499  
Spannbereich / clamping range: 2,0 - 20,0

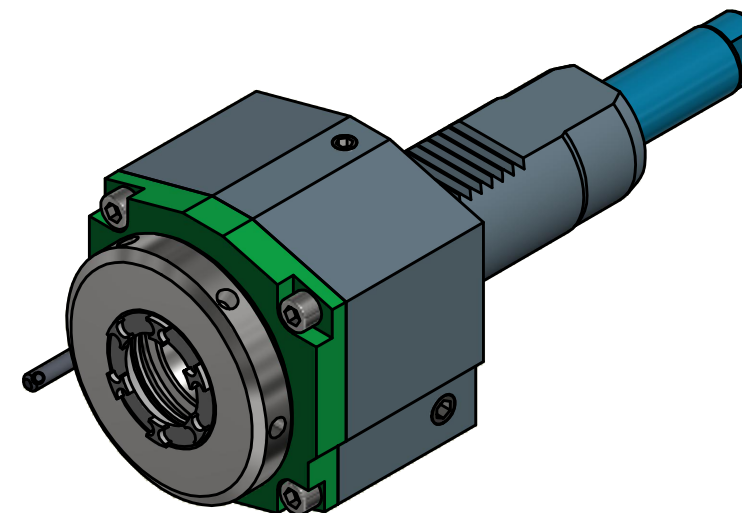
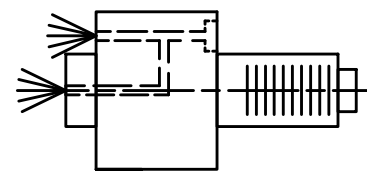

Hakenschlüssel mit Zapfen  
Hook wrench with fixed pin  
DIN1810 B 68x75

Spannzangenschlüssel für innenliegende Mutter  
Clamping wrench for internal collet  
232AX

Innen- und Aussenkuehlung / Inside and outside coolant supply  
Kuehlmittelfiltrierung <math>50\mu</math> / coolant filtration <math>50\mu</math>

Bemerkung - Note  
Für Trockenlauf geeignet!  
Use without coolant fluid allowed!

Technische Daten - technical data  
Weight = 3.970 [kg]  
Torque max. (M1/M2) = 50 / 50 [Nm]  
Speed max. (n1/n2) = 6000 / 6000 [1/min]  
Gear ratio (i)=n1:n2 = 1:1  
Pressure (pmax) = 70 [bar]

Benennung - Title  
**Axial Bohr und Fräskopf**  
**Axial drilling and milling head**

**EWS** Tool Technologies  
EWS Weigle GmbH & Co. KG  
Maybachstr. 1  
D-73066 Utingen  
www.ews-tools.de

Technische Aenderungen vorbehalten!  
Subject to technical modifications!

IDENT: DEWS128563

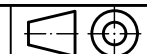

REV: -/B

Nr. - No.

40.4032VTCIKCIM

MNR.

211254



Copyright **EWS Tool Technologies**  
Weitergabe und Vervielfaeltigung dieser Unterlage,  
Verwertung und Mitteilung ihres Inhalts nicht  
gestattet, soweit nicht ausdrucklich zugestanden.  
Zuwiderhandlungen verpflichten zu Schadenersatz.