

Spannzange / collet ER25 DIN6499
Spannbereich / clamping range: 1,0 - 16,0

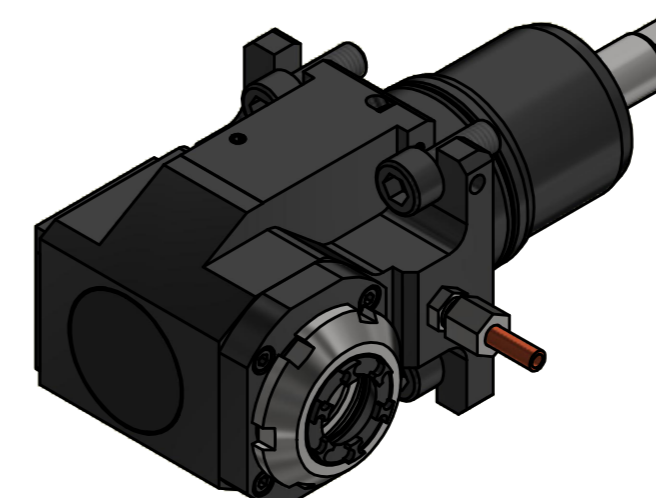
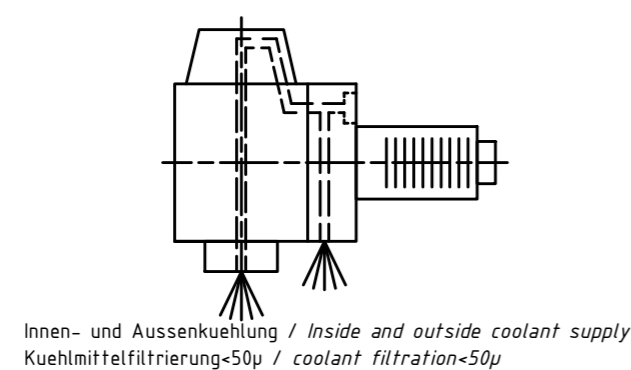
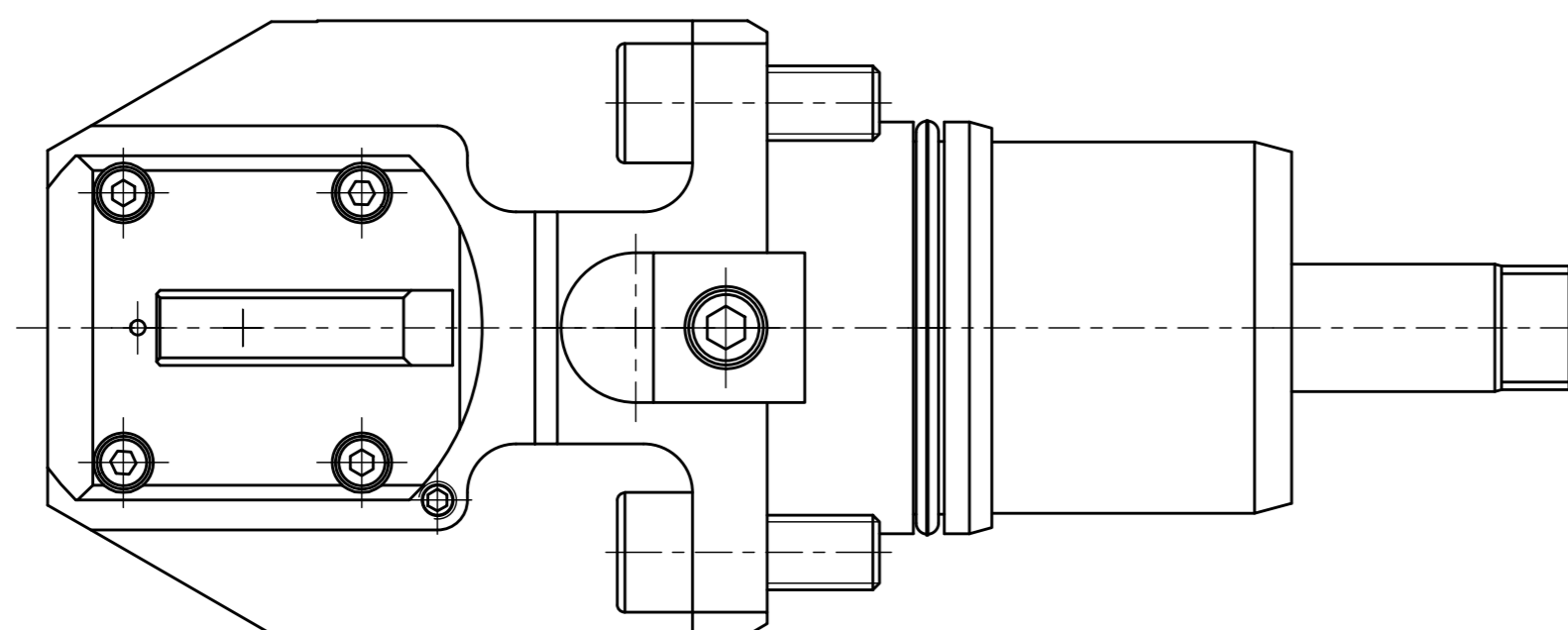

Hakenschlüssel mit Nase
Hook wrench with nose end
DIN1810 A 52x55

Spannzangenschlüssel für innenliegende Mutter
Clamping wrench for internal collet
225AX

Copyright **EWS Tool Technologies**
Weitergabe und Vervielfaeltigung dieser Unterlage, Verwertung und Mitteilung ihres Inhalts nicht gestattet, soweit nicht ausdruecklich zugestanden. Zuwiderhandlungen verpflichten zu Schadenersatz.

Bemerkung - Note
Für Trockenlauf geeignet!
Use without coolant fluid allowed!

Technische Daten - technical data
Weight = 4.210 [kg]
Torque max. (M1/M2) = 25 / 25 [Nm]
Speed max. (n1/n2) = 10000 / 10000 [1/min]
Gear ratio (i)=n1:n2 = 1:1
Pressure (pmax) = 70 [bar]

Benennung - Title
Radial Bohr und Fräskopf
Radial drilling and milling head

EWS Tool Technologies
EWS Weigle GmbH & Co. KG
Maybachstr. 1
D-73066 Uhlingen
www.ews-tools.de

Technische Aenderungen vorbehalten!
Subject to technical modifications!
IDENT: DEWS23114.0
REV: -/B
MNR.
218273

