

Spannzange / collet ER32 DIN6499
 Spannbereich / clamping range: 2,0 - 20,0

Beide Nachbarstationen nicht verwendbar!
 both neighbouring are not useable!

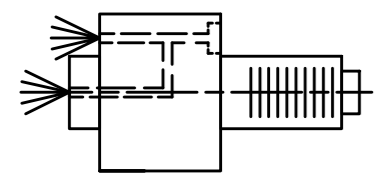

Innen- und Aussenkuehlung / Inside and outside coolant supply
 Kuehlmittelfiltrierung-50µ / coolant filtration-50µ

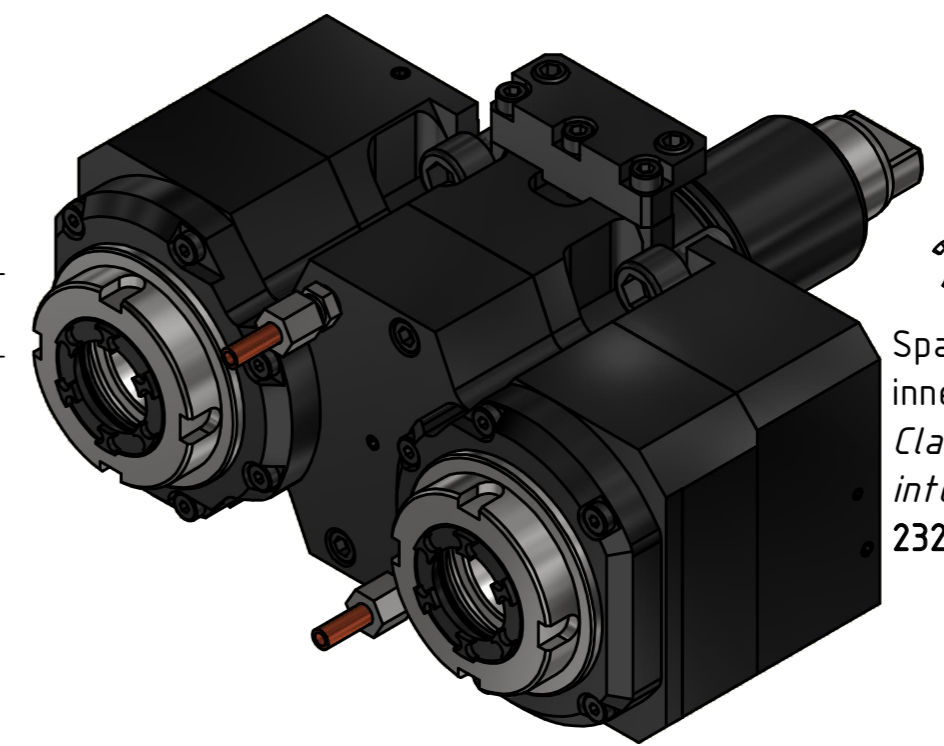

Spannzangenschlüssel für innenliegende Mutter
 Clamping wrench for internal collet
 232AX

Hakenschlüssel mit Nase
 Hook wrench with nose end
 DIN1810 A 58x62

Copyright EWS Tool Technologies
 Weitergabe und Vervielfaeltigung dieser Unterlage,
 Verwertung und Mitteilung ihres Inhalts nicht
 gestattet, soweit nicht ausdrecklich zugestanden.
 Zuwiderhandlungen verpflichten zu Schadenersatz.

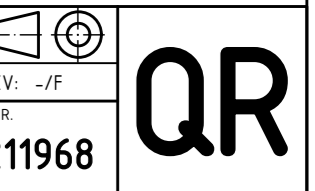
Bemerkung - Note Für Trockenlauf geeignet! Use without coolant fluid allowed!	Technische Daten - technical data Weight = 13.974 [kg] Torque max. (M1/M2) = 40 / 40 40 [Nm] Speed max. (n1/n2) = 6000 / 3000 [1/min] Gear ratio (i)=n1:n2 = 2,053:1 Pressure (pmax) = 70 [bar]	Benennung - Title Axial Bohr und Fräskopf Axial drilling and milling head	 EWS Weigle GmbH & Co. KG Maybachstr. 1 D-73066 Uhlingen www.ews-tool.de Technische Aenderungen vorbehalten! Subject to technical modifications! IDENT: DEWS123000 Nr. - No. 40.6532DYVL6IKDI2IMTK134-S01	 REV: -/F MNR. 211968
---	--	---	---	---