

Spannzange / Collet ER16 DIN6499
 Spannbereich / Clamping range: 1,0 - 10,0

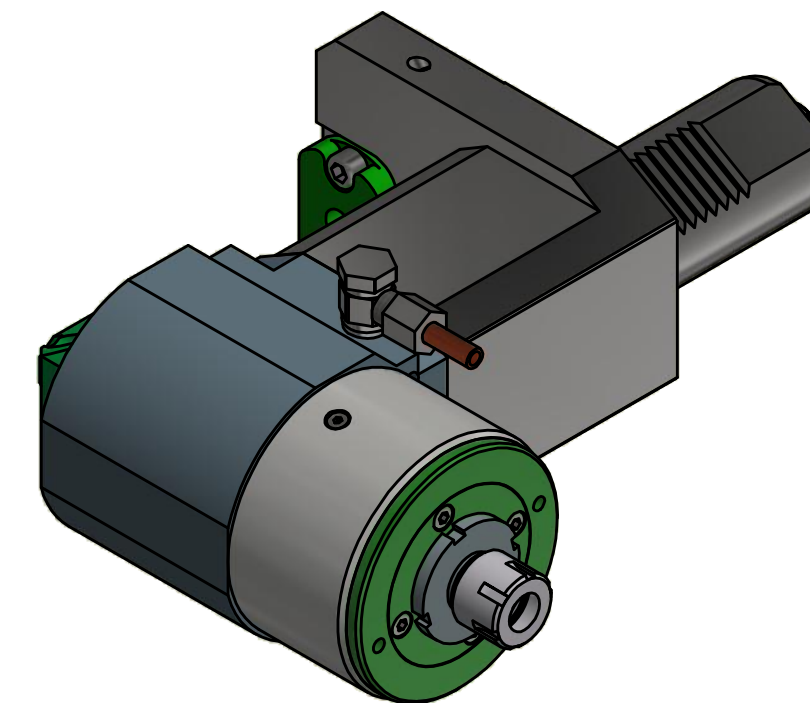
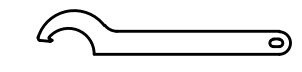
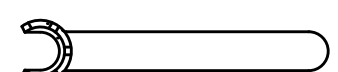

 Hakenschlüssel mit Nase
 Hook wrench with nose end
 DIN1810 A 36x38

 Spannzangenschlüssel
 Clamping wrench
 216 M

Fettschmierung mit Klüber Isoflex NCA 15
 Alle 100 Betriebsstunden mit ca. 1cm³ Fett nachschmieren
*Grease lubrication with Klüber Isoflex NCA 15
 relubricate every 100 operating hours with about 1cm³ of grease*

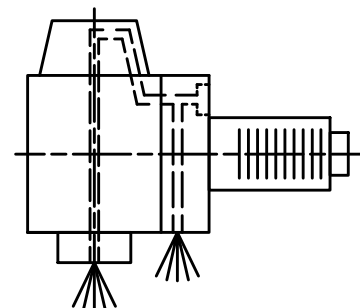

Innen- und Aussenkuehlung / Inside and outside coolant supply
 Kein Trockenlauf / No dry run
 Kuehlmittelfiltrierung=50µ / coolant filtration=50µ

Copyright **EWS Tool Technologies**
 Weitergabe und Vervielfaeltigung dieser Unterlage,
 Verwertung und Mitteilung ihres Inhalts nicht
 gestattet, soweit nicht ausdrecklich zugestanden.
 Zuwiderhandlungen verpflichten zu Schadenersatz.

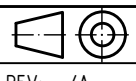
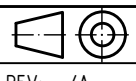
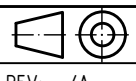
| | | | | | | | | | |
|--|--|---|--|--|---|---|------------------------------------|--------|-----------|
| Bemerkung - Note Nicht ohne Kuehlmittel betreiben! Not for use without coolant-fluid! | Technische Daten - technical data Weight = 8.123 [kg] Torque max. (M1/M2) = 25 / 5 [Nm] Speed max. (n1/n2) = 4800 / 24000 [1/min] Gear ratio (i)=n1:n2 = 1:5 Pressure (pmax) = 70 [bar] | Benennung - Title Radial Bohr und Fräskopf Radial drilling and milling head | <table border="1"> <tr> <td data-bbox="2226 1915 2463 1984"> EWS <small>EWS Weigle GmbH & Co. KG Maybachstr. 1 D-73066 Uhlingen www.ews-tools.de</small> </td> <td data-bbox="2463 1915 2686 1984"> Technische Aenderungen vorbehalten! Subject to technical modifications! IDENT: DEWS062299 </td> <td data-bbox="2686 1915 2929 1984">  REV: -/A MNR. </td> </tr> <tr> <td data-bbox="2226 1984 2463 2045"> Nr. - No. 60.4016SQT15RIK115#01 </td> <td data-bbox="2463 1984 2686 2045"> 211913 </td> <td data-bbox="2686 1984 2929 2045"> QR </td> </tr> </table> | EWS <small>EWS Weigle GmbH & Co. KG Maybachstr. 1 D-73066 Uhlingen www.ews-tools.de</small> | Technische Aenderungen vorbehalten! Subject to technical modifications! IDENT: DEWS062299 |  REV: -/A MNR. | Nr. - No. 60.4016SQT15RIK115#01 | 211913 | QR |
| EWS <small>EWS Weigle GmbH & Co. KG Maybachstr. 1 D-73066 Uhlingen www.ews-tools.de</small> | Technische Aenderungen vorbehalten! Subject to technical modifications! IDENT: DEWS062299 |  REV: -/A MNR. | | | | | | | |
| Nr. - No. 60.4016SQT15RIK115#01 | 211913 | QR | | | | | | | |