

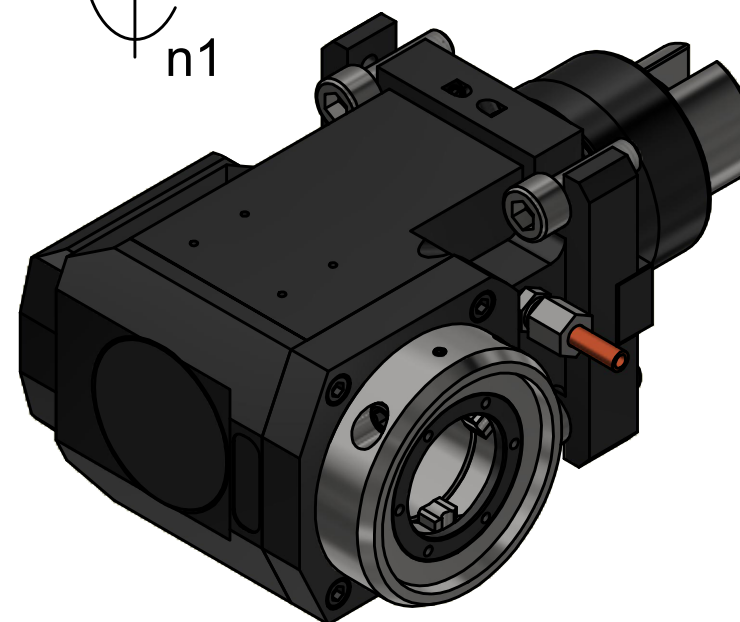

EWS.Varia

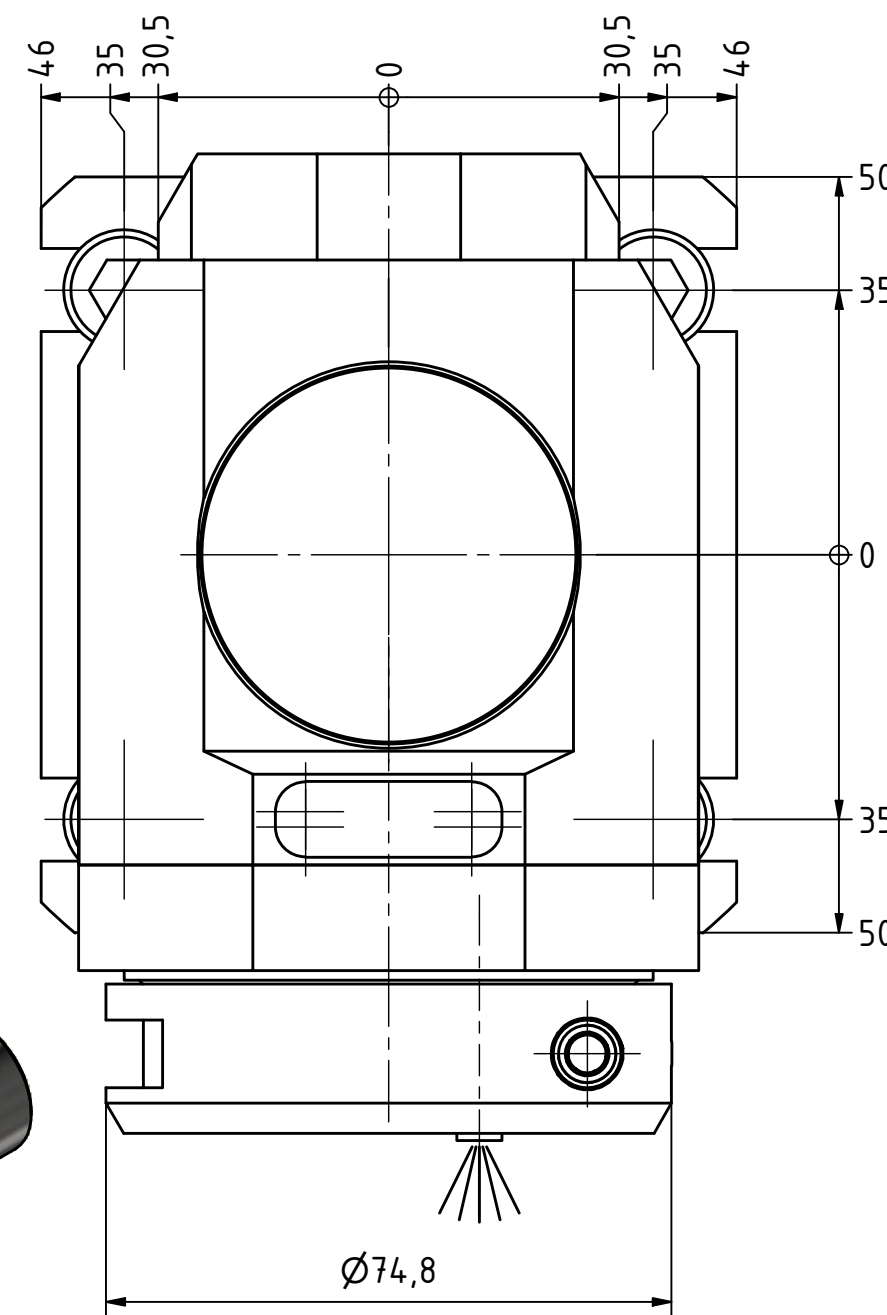

Tech  
Details

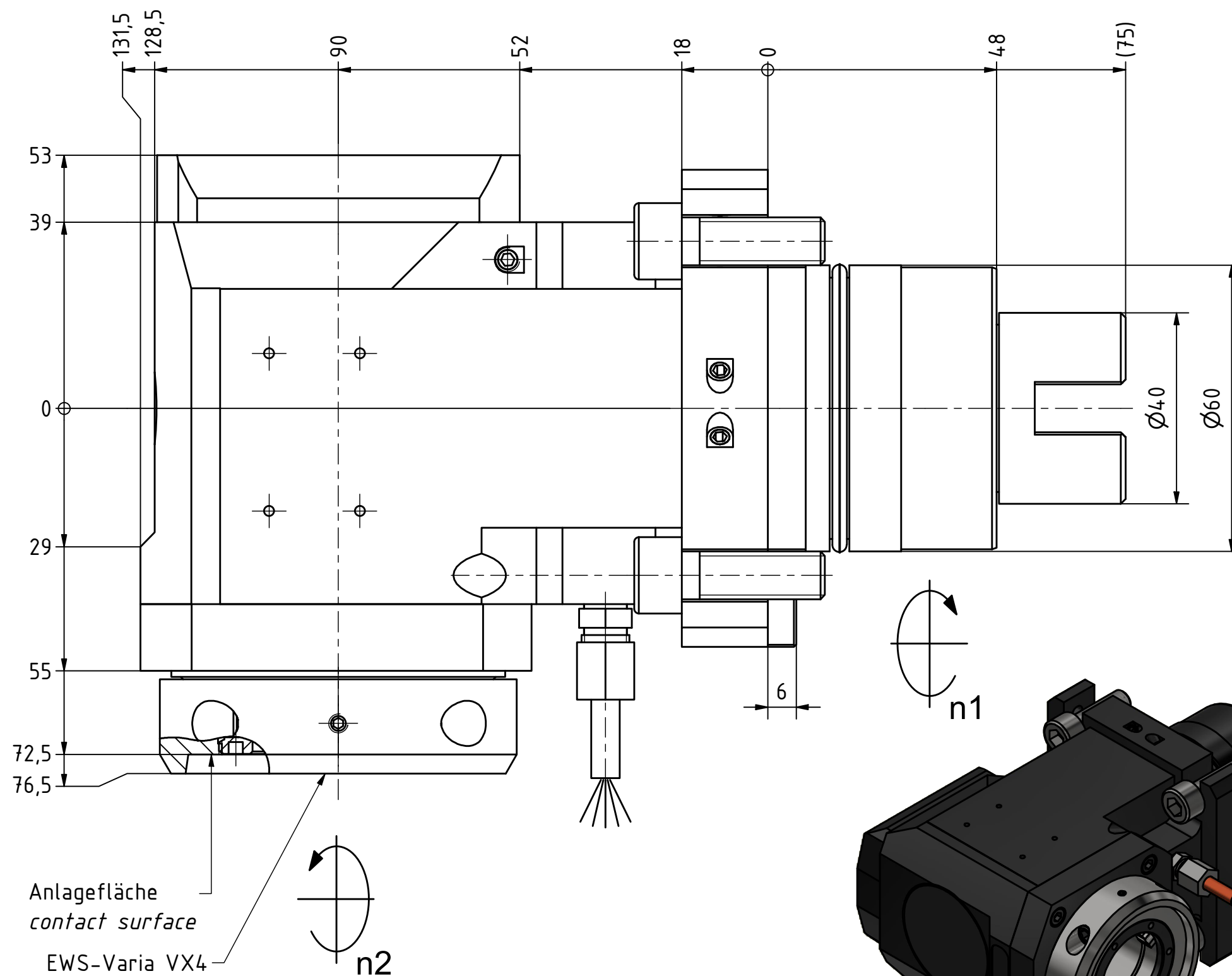

Copyright **EWS Tool Technologies**  
 Weitergabe und Vervielfaeltigung dieser Unterlage,  
 Verwertung und Mitteilung ihres Inhalts nicht  
 gestattet, soweit nicht ausdrecklich zugestanden.  
 Zuwiderhandlungen verpflichten zu Schadenersatz.

Bemerkung - Note  
 mit Kegetrollenlager  
 with taper roller bearing(s)

Technische Daten - technical data  
 Weight = 7.650 [kg]  
 Torque max. (M1/M2) = 40 / 80 [Nm]  
 Speed max. (n1/n2) = 6000 / 3000 [1/min]  
 Gear ratio (i)=n1:n2 = 2:1

Benennung - Title  
**Radial Bohr und Fräskopf**  
**Radial drilling and milling head**

**EWS**  
 Tool Technologies  
 EWS Weigle GmbH & Co. KG  
 Maybachstr. 1  
 D-73066 Uthingen  
 www.ews-tools.de

Technische Aenderungen vorbehalten!  
 Subject to technical modifications!

IDENT: DEWS264142



REV: -/B

Nr. - No.

60.60VX4KREX508BMT12

MNR.

211350

QR