

Trifix Anzugsdrehmoment 25 Nm
 Trifix clamping torque 25 Nm

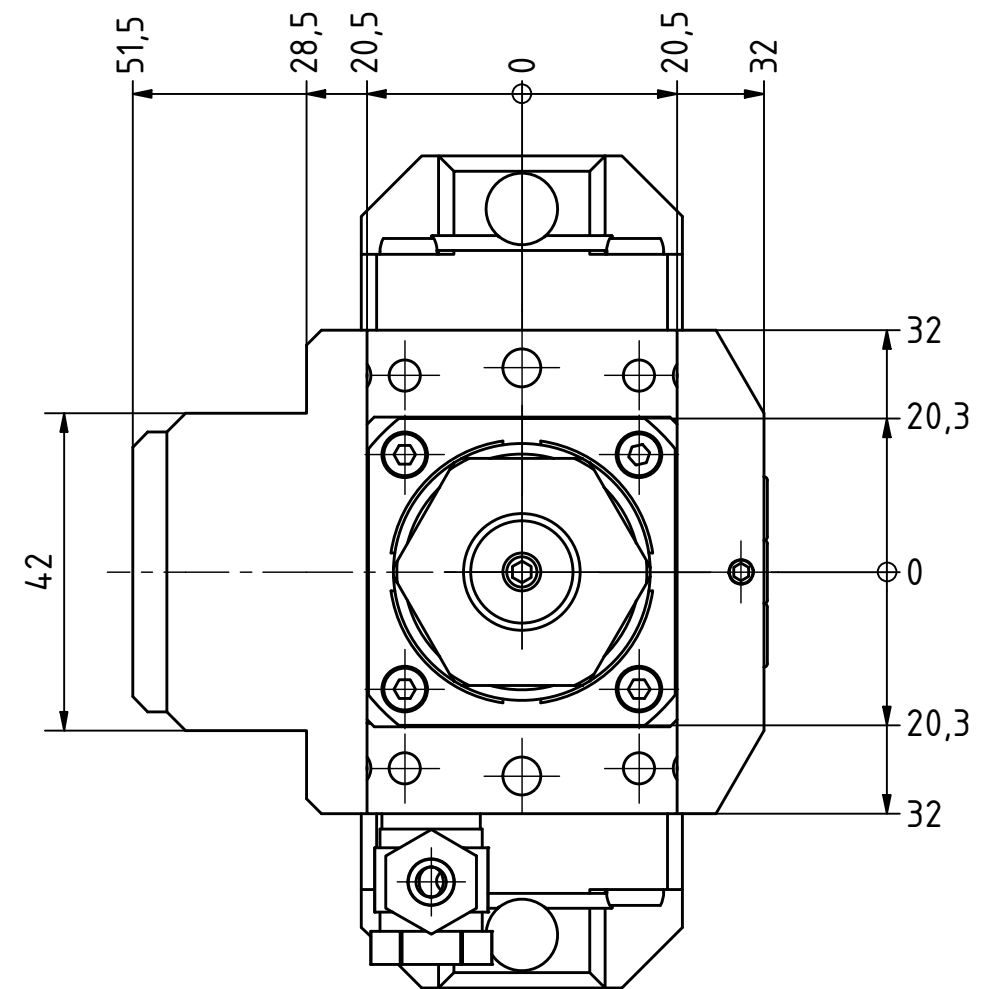

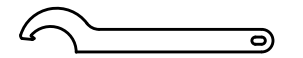
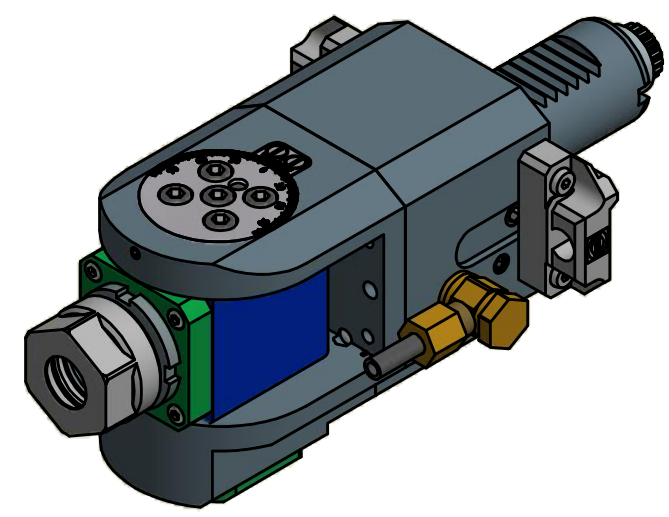

Spannzange / collet ER20 DIN6499
 Spannungsbereich / clamping range: 1,0 - 13,0

Gewindebohrzange / tapping collet
 ET-1-20 M2-M6



Hakenschlüssel
 mit Nase
 Hook wrench with
 nose end
 DIN1810 A 34x36

Copyright **EWS Tool Technologies**
 Weitergabe und Vervielfaeltigung dieser Unterlage,
 Verwertung und Mitteilung ihres Inhalts nicht
 gestattet, soweit nicht ausdruercklich zugestanden.
 Zuwiderhandlungen verpflichten zu Schadenersatz.

| | | | | | | |
|------------------|------------------------------------------------------------------------------------------------------------------------------------------------------------------------------------------------------|-------------------|------------------------------------------------------------------------------------------------------------------------------------------------------------------------|-------------------------------------------------------------------------------------------------|---------------------------------------------------------------------------------------------------------------------|---------------------------------------------------------------------------------------|
| Bemerkung - Note | Technische Daten - technical data Weight = 4.383 [kg] Torque max. (M1/M2) = 16 / 16 [Nm] Speed max. (n1/n2) = 8000 / 8000 [1/min] Gear ratio (i)=n1:n2 = 1:1 | Benennung - Title |  EWS Weigle GmbH & Co. KG Maybachstr. 1 D-73066 UHINGEN www.ews-tools.de | Technische Aenderungen vorbehalten! Subject to technical modifications! IDENT: DEWS053439 |  REV: -/A MNR. 209462 |  |
| | | | Nr. - No. 63.3020GT300TF | | | |